

# Preparatory Studies for Ecodesign Requirements of EuPs (III)

ENER Lot 20 – Local Room Heating Products  
Task 6: Technical analysis BAT

European Commission, DG ENER  
25 June 2012



Developed by:  bio Intelligence Service

## Project description

CLIENT:	European Commission DG ENER	
CONTRACT NUMBER:	TREN/D3/91-2007-Lot 20-SI2.519986	
REPORT TITLE:	ENER Lot 20 – Local Room Heating Products Task 6: Technical analysis BAT	
REPORT SUB-TITLE:	Final report	
PROJECT NAME:	Preparatory Studies for Ecodesign Requirements of EuPs (III)	
PROJECT CODE:	EUP20	
DATE:	25 June 2012	
PROJECT TEAM	BIO Intelligence Service	
AUTHORS:	Mr. Shailendra Mudgal, BIO Intelligence Service Dr. Adrian Tan, BIO Intelligence Service Mr. Sandeep Pahal, BIO Intelligence Service Mr. Alvaro de Prado Trigo, BIO Intelligence Service	
KEY CONTACTS:	Shailendra Mudgal + 33 (0) 1 53 90 11 80 <a href="mailto:sm@biois.com">sm@biois.com</a>	Adrian Tan + 33 (0) 1 53 90 11 80 <a href="mailto:adrian.tan@biois.com">adrian.tan@biois.com</a>

**ACKNOWLEDGEMENTS** TÜV Rheinland contributed to the first version of this report. The ENER Lot 20 project team would like to thank all the registered stakeholders of this study for their valuable contribution in terms of comments and inputs provided throughout the course of this study. Professor Bert Oschatz (ITG Institute for Building Systems Engineering Dresden) supported the project team with his expertise and knowledge of local room heaters.

**DISCLAIMER** This document has been prepared for the European Commission however it reflects the views only of the authors, and the Commission cannot be held responsible for any use which may be made of the information contained therein.

The project team does not accept any liability for any direct or indirect damage resulting from the use of this report or its content.

### Please cite this publication as:

BIO Intelligence Service (2012) Preparatory Studies for Ecodesign Requirements of EuPs (III), ENER Lot 20 – Local Room Heating Products – Task 6: Technical analysis BAT prepared for the European Commission, DG ENER.

*Photo credit:* cover @ Per Ola Wiberg

# Table of Contents

<b>TASK 6:</b>	<b>TECHNICAL ANALYSIS OF BEST AVAILABLE TECHNOLOGY (BAT)</b>	<b>7</b>
6.1	State-of-the-art for the products	7
6.1.1	Open combustion/chimney connected flued gas heaters	7
6.1.2	Open combustion/chimney connected flued gas fire	9
6.1.3	Electric fan heater (portable)	10
6.1.4	Electric convector (fixed)	10
6.1.5	Static electric storage heaters	12
6.1.6	Dynamic electric storage heaters	12
6.1.7	Electric underfloor heating	13
6.1.8	Warm air unit heaters	14
6.1.9	Radiant gas-fired heaters	15
6.1.10	Air curtains	17
6.2	State-of-the-art at component level	20
6.2.1	Heat generator	20
6.2.2	Ignition device	23
6.2.3	Thermal insulation of heaters	24
6.2.4	Controls	25
6.2.5	Summary of BAT options at component level	26
6.3	State-of-the-art of best existing product technology outside the EU	31
6.4	Conclusion and summary	32

## List of Tables

Table 6-1: Summary of BAT options for BC 1 (open combustion flued gas heater)	27
Table 6-2: Summary of BAT options for BC 2 (open combustion flued gas fire)	27
Table 6-3: Summary of BAT options at component level BC 3 (portable fan heater)	28
Table 6-4: Summary of BAT options for BC 4 (electric fixed convector)	28
Table 6-5: Summary of BAT options at component level BC 5a (static storage heaters)	28
Table 6-6: Summary of BAT options at component level BC 5b (dynamic storage heaters)	29
Table 6-7: Summary of BAT options at component level BC 6a (electric underfloor as primary heating)	29
Table 6-8: Summary of BAT options at component level BC 6b (electric underfloor as secondary heating)	29
Table 6-9: Summary of BAT options at component level BC 7 (warm air unit heater)	30
Table 6-10: Summary of BAT options at component level BC 8a (radiant luminous gas heaters)	30
Table 6-11: Summary of BAT options at component level BC 8b (radiant tube gas heaters)	31
Table 6-12: Summary of BAT options at component level BC 9 (air curtains)	31

## List of Figures

Figure 6-1: Flue gas damper	8
Figure 6-2: Diagram of a balanced flue system	9
Figure 6-3: State-of-the-art electric radiator and controls	11
Figure 6-4: State-of-the-art static electric storage heater	12
Figure 6-5: Dynamic electric storage heater	13
Figure 6-6: Control schematic of an electric underfloor storage heating system	14
Figure 6-7: Diagram of a luminous radiant heater	16
Figure 6-8: Reduction of heat losses achieved by insulation of heater	16
Figure 6-9: Diagram of a radiant sensor and central control device	17
Figure 6-10: Air curtain	18
Figure 6-11: Diagrams of the principles of conventional air curtains (increasing the discharge velocity) and air curtains using air stream technology (widening the air stream).	19

Figure 6-12: Porous combustion process	23
Figure 6-13: Electric spark igniter (oil burner)	23
Figure 6-14: Diagram of a piezo igniter in common lighter	24
Figure 6-15: Diagram of an electric storage heater control system	26

*This page is intentionally left blank*

## Task 6: Technical analysis of best available technology (BAT)

A Best Available Technology (BAT) for a product in this study is a technology or change in design that leads to less environmental impacts and is already available on the market, or whose technical feasibility has already been demonstrated (and expected to be introduced within 2-3 years). Best Not yet Available Technology (BNAT) refers to a technology that has the potential to lead to further environmental performance improvements, but still is subject to research and development. BNAT is rather a future option or long term trend.

The identification and analysis of BAT and BNAT provides input for the assessment of the improvement potential in Task 7. The intellectual property, technical feasibility and the availability on the market of BATs in a strict sense are not judged here as the objective is to illustrate various technically available (or potentially available) options. However, Task 7 will take these issues into account when suggesting possible improvement options applicable to local room heating products.

The results of this task are predominantly based upon available literature, which includes technical journals, magazines and research publications, as well as other sources such as interviews with technology experts, research institutes and the stakeholders of this study.

### 6.1 State-of-the-art for the products

**T**his section presents an overview of the BATs currently available on the market both at the component and product level for the Base Cases selected in Task 5. BATs are design options, which allow a product to operate significantly better in terms of environmental performance than the average product on the market (represented by the Base Cases).

#### 6.1.1 Open combustion/chimney connected flued gas heaters

Open combustion gas heaters use air supplied from the room they are installed in and evacuate the flue gases via the chimney to the outside. Inherently, the latter implicates that a substantial amount of energy is lost due to flue discharge to the atmosphere.

Figure 6-1: Flue gas damper<sup>1</sup>

State-of-the-art chimney connected gas heaters are equipped with a flue gas damper (see Figure 6-1) that is capable of realising substantial energy savings. The device is installed in the flue gas tract. During downtime of the heater, the damper is closed and thus prevents heat losses via the chimney. It is estimated that significant losses can be avoided and a payback period of 1 to 2 years can be expected. It is not usual (standard) to install this device at the moment. The chimney's second function is to ventilate the room (approximately  $0.55 - 2 \text{ l/s}\cdot\text{m}^2$ )<sup>2</sup>. Blocking this when the heater is not in operation will affect the performance, and also the required ventilation needed in the room.

In addition to flue gas dampers, highly efficient products comprise modulating burners in order to adjust air and gas supply to meet the heat demand. In this context, premixing and modulating gas burners with low  $\text{NO}_x$  emissions represent state-of-the-art technology, but the disadvantage of premix burners is that they might be more expensive and noisy. Burners equipped with modulating controls are capable of regulating air and gas supply, and thus allow a continuous operation. This is achieved by modulating motors with conventional mechanical linkage or electric driven valves. Beyond that, premix burners with an automatic mixing set enables an optimal ratio of the air/gas-mixture before it is blown inside the burner. Premix burners are more efficient compared to atmospheric ones as they offer an increased level of control with regard to the air and gas mix and thus allow a simple and accurate flame control as well as a higher flame temperature. On the other hand, atmospheric burners do not require electrical energy for any controlling devices as combustion air is entrained automatically.

The BAT for manually operated gas heaters is a piezoelectric spark ignition device that substantially reduces energy consumption as no permanent burning pilot flame is required. Compared to semiautomatic controls, fully automated controls may reduce gas consumption by approx. 1.5%<sup>3</sup>, if the customer does not cut off the ignition flame in the summer period.

A potential BAT option at product level is direct vent heaters that use closed combustion chambers and a balanced flue gas system. The direct vent heaters have a concentric pipe system. The inner pipe is used for venting the hot exhaust gases to the outside, while the outer pipe supplies outside air into the combustion chamber. As the outside air is sucked into the concentric pipe system, it is preheated, thus improving the overall efficiency (see Figure 6-2).

<sup>1</sup> Oranier Heiztechnik GmbH. [www.oranier-heiztechnik.de](http://www.oranier-heiztechnik.de)

<sup>2</sup> Olesen, B. (2011) Standards for ventilation and indoor air quality in relation to the EPBD. Rehva Journal.

<sup>3</sup> Stakeholder feedback

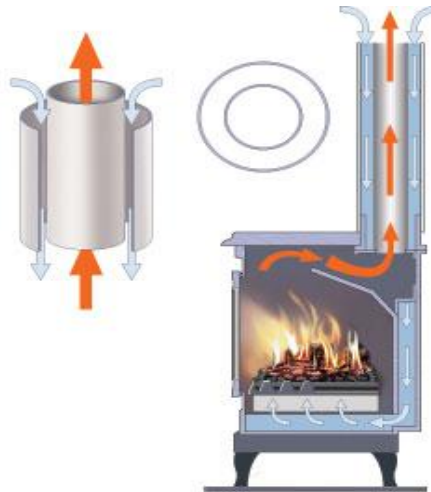

Figure 6-2: Diagram of a balanced flue system<sup>4</sup>

Open combustion gas heaters (and fires) have an open-fronted burner assembly that draws in the combustion air from inside the heated space and the exhaust gases are expelled outside by the flue pipe. In contrast to open combustion devices, a balanced flue gas system is room-sealed using a glass front. It has a sophisticated flue that uses natural convection to draw the air from outside the building for combustion and expels it back to the outside through a separate compartment of the flue. This is usually accomplished by using a concentric flue gas pipe system. Since the double-walled flue pipe acts as an heat exchanger, the combustion air (outer tube) is preheated by the hot flue gases (inner tube) the flue gas losses are reduced and the efficiency of the combustion process is increased. This can save up to 20% of energy consumption<sup>5</sup>.

### 6.1.2 Open combustion/chimney connected flued gas fire

High efficiency open combustion/chimney connected flued gas fires with a glass front are substantially more energy efficient compared to conventional fires with an open front. This is due to the reduced circulation of air from the room to the fire that has to be heated. Whereas open fronted fires replenish the inside air of the heated space up to 12 times per hour, a closed glass fronted device replenishes it only once. The glass fronts are made of specially tempered glass or ceramic glass that can withstand the high temperatures generated inside the fire, and thus provide a high radiant heat. Minimum room air replenishments of the heated space combined with superior thermal efficiency achieved by ceramic glass-front technology substantially improves the overall efficiency and performance.

Similar to flued gas heaters, energy efficiency is mainly determined by the burner technology used. The burner should be capable of modulating and thereby adjusting heat generation to the heat demand, which reduces fuel consumption. Additionally the exhaust gas venting system has a major influence on the performance of the heater.

<sup>4</sup> EUROHEAT Distributors (HBS) Ltd. Euroheat Natural Energy Company. Gas Balanced Flue Options. [www.euroheat.co.uk/accesso.php?style=Balanced Flue Pipe&csss=Harmony](http://www.euroheat.co.uk/accesso.php?style=Balanced+Flue+Pipe&csss=Harmony)

<sup>5</sup> Estimation based on the thermal efficiency figures quoted by manufacturers in their residential gas-heater manuals

As already mentioned in section 6.1.1, balanced flue fires also represent a BAT option at the product level for flued gas fires (BC 2). Best-available balanced flue fires contain the following components:

- An intermittent electronic ignition system or an easy means of turning off and relighting the pilot flame
- A direct-vent concentric flue gas design
- A ceramic glass front
- A quiet squirrel-cage-type circulating fan for forced convective heat transfer to the heated space
- An insulated outer casing to prevent heat loss through the walls to the outside if located on an exterior wall

### 6.1.3 Electric fan heater (portable)

Portable electric fan heaters are normally used for secondary heating purposes on an ad-hoc (provisional) basis and are suited for focused heat distribution.

As the heat generation by portable electric fan heaters offers little improvement potential with regard to energy efficiency, contemporary design options focus on response time, temperature controls and different operation modes concerning heat output. On-off two step controls may lead to energy savings of 82%, while advanced controls such as a thermostat PI controller may lead to energy savings of up to 84% for portable electric fan heaters with reference to the case of a product without a thermostat<sup>6</sup>.

### 6.1.4 Electric convector (fixed)

Generally, electric heating systems offer limited opportunity for improving energy efficiency as all the electricity is converted into thermal energy. Nevertheless, controls may reduce energy consumption in indoor spaces by up to 29%.<sup>7</sup>

Overall, highly efficient products consist of adjustable time programs and heat settings, overheating shut-off functions and dynamic control depending on outside temperatures. Moreover, the best products on the market comprise room thermostats that are capable of reacting to heat gains such as solar heat input, body heat, and thus avoid overheating.

Besides natural draught electric convector heaters, forced-air electric convector heaters use fans to create a forced draught. Highly efficient fan-based devices comprise direct driven fans that are powered by state-of-the-art energy efficient brushless permanent magnet DC motors, so-called Electronically Commutated (EC) motors.

---

<sup>6</sup> Stakeholder feedback (CECED)

Figure 6-3: State-of-the-art electric radiator and controls<sup>8</sup>

Although electric room heaters work with a local heat generation efficiency of 100% (Joule effect), the real efficiency can be far lower when electric power generation efficiency and grid losses are taken into account (as described in Task 4). However the control systems, built-in or as separate control systems could make a difference in real life energy consumption. Precise temperature control, zone heating and variation of temperature in presence and non-presence periods can make a significant difference compared to uncontrolled products and heating systems.

Modern fixed electric heaters with electronic thermostats have proven to have precise and sensitive temperature regulation with no overshoot and the full capacity to adjust to the changing heat demands.

The use of heat pumps to reduce energy consumption in houses originally heated with electric room heaters is a well established practice in several EU countries. Air-to-air (heating only) heat pumps can therefore be considered as a BAT for electric fixed heaters at the product level<sup>9</sup>. State-of-the-art heat pumps can lead to energy saving of 50-75% as compared to the conventional fixed electric heaters<sup>10</sup>.

<sup>8</sup> Sira Group. Electron Line Electric Radiators. Onice product brochure. [www.siragroup.it/en/radiators-detail.php?id=1](http://www.siragroup.it/en/radiators-detail.php?id=1)

<sup>9</sup> Several stakeholders however pointed out that this is not the case especially for the Nordic countries, where air-to-air heat pumps cannot stand alone, but will need supplementary room heaters like electric heating panels or stoves to fulfil space heating demand and comfort. So talking about a one-to-one product replacement of e.g. fixed electric heating panels is not relevant.

<sup>10</sup> Stakeholder feedback (INFORSE)

## 6.1.5 Static electric storage heaters

Static electric storage heaters store heat during off-peak periods (benefitting from cheaper electricity prices compared to peak load). The heat storage is achieved by special heat-retaining bricks that are properly insulated. They release heat during the day. The storage capacity highly depends on the quality of the storage bricks used inside the heater. State-of-the-art static storage heaters use iron ore storage bricks with especially high core density.

Static storage heaters typically have manual charging controls with limited ability to manage the temperature of the inner core and the heat already available in the storage. As stored heat is released automatically a draught or output control is not included. Static storage heaters equipped with intelligent charge controls may become an integral part of an improved load management power grids particularly regarding renewable energies (e.g. "smart grids").

Generally, static electric storage heaters offer limited opportunity for improving energy efficiency as all the electricity is converted into thermal energy. Nevertheless, controls such as automatic (electro-mechanical) charge control (built in the heater – thermostat for the core temperature) may reduce energy consumption in indoor spaces by 5-12%<sup>11</sup>.

Figure 6-4: State-of-the-art static electric storage heater<sup>12</sup>

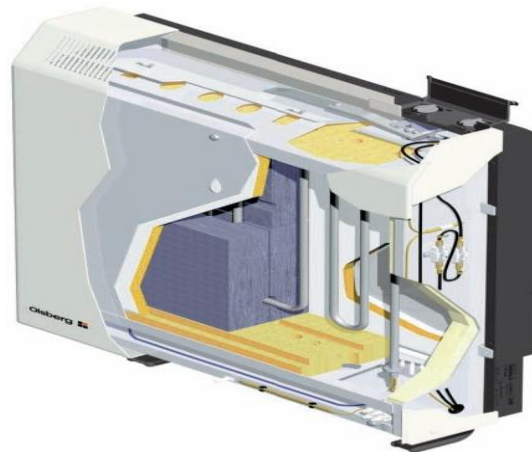

## 6.1.6 Dynamic electric storage heaters

Dynamic storage heaters can be considered as a potential BAT option at a product level for static storage heaters. Dynamic storage heaters have precise charging controls that manage the temperature fluctuation during charging process and the heat already available in the storage in relation to the actual and predicted outside temperature. As described in Task 4, dynamic heaters are also equipped with fans to allow additional forced convection for the heat transfer. A ventilation fan introduces surrounding air to the charged core of the heater. The air is heated and released to the heated space. Dynamic storage heaters can control heat distribution more

<sup>11</sup> Based on the feedback of a manufacturer of static storage heaters

<sup>12</sup> Olsberg Hermann Everken GmbH. Our electric heating range brochure. [www.olsberg.com/wDeutsch/heiz-und-lueftungssysteme/download\\_oeffentlich/inhalte/folder\\_export\\_english.pdf](http://www.olsberg.com/wDeutsch/heiz-und-lueftungssysteme/download_oeffentlich/inhalte/folder_export_english.pdf)

precisely according to the room temperature as compared to static storage heaters. Due to the forced air movement caused by the ventilation fan, the storage core can be produced in a larger size, which is why dynamic storage heaters can have a higher heating capacity than static storage heaters.

Similar to static storage heaters, dynamic storage heaters with intelligent charge control on a building or appliance level, could also become part of a demand management system for power grids, particularly regarding times of abundance renewable energies (e.g. "smart grids").

Figure 6-5: Dynamic electric storage heater<sup>13</sup>

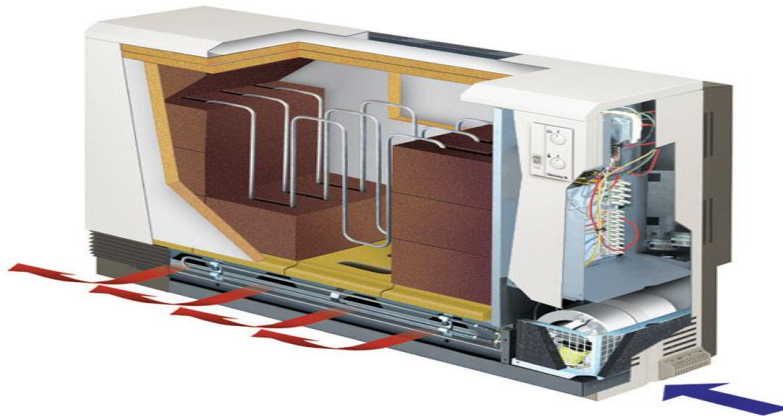

Generally, dynamic electric storage heaters offer limited opportunity for improving energy efficiency as all the electricity is converted into thermal energy. Nevertheless, controls such as automatic electronic charge control, thermostat output control and other sophisticated controls (advanced algorithms for charging and discharging) may reduce energy consumption in indoor spaces by 6-15%<sup>14</sup>.

### 6.1.7 Electric underfloor heating

Electric underfloor heating systems are heating mats or cables that are installed under floor surfaces or in walls and ceilings. Underfloor heating systems are typically used in bathrooms and kitchen, but can be used throughout the entire home. Each room is separately controlled with a thermostat with just a floor sensor for well thermally insulated rooms, and for poorly insulated rooms a thermostat with both a room and floor sensor should be used.

Underfloor heating systems can be used for both primary and secondary heating purposes. The control strategy for electric underfloor heating systems strongly depends on the function of the system.

Electric underfloor heating system control units are beginning to be more common with remote controls so they can be controlled and monitored from a master system. This allows the heating to be managed better to increase the energy efficiency performance.

<sup>13</sup> Olsberg Hermann Everken GmbH. Our electric heating range brochure. [www.olsberg.com/wDeutsch/heiz-und-lueftungssysteme/download\\_oeffentlich/inhalte/folder\\_export\\_english.pdf](http://www.olsberg.com/wDeutsch/heiz-und-lueftungssysteme/download_oeffentlich/inhalte/folder_export_english.pdf)

<sup>14</sup> Based on the feedback of a manufacturer of dynamic storage heaters

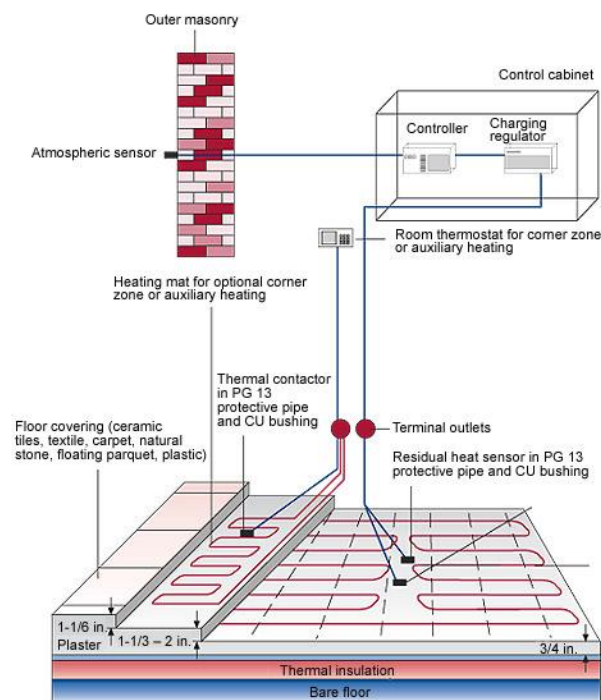
Figure 6-6: Control schematic of an electric underfloor storage heating system<sup>15</sup>

Electric heating elements convert 100% of the electric energy into heat, therefore no major efficiency improvements are to be expected for the heat generation except for the thermal insulation and control units, which are elaborated later in the sections 6.2.3 and 6.2.4.

Controls for electric underfloor heating available on the market are able to provide different control strategies depending on the function of the systems. The typical control options are precise thermostat controls, programmable thermostats, zoning controls and open window detection sensors.

## 6.1.8 Warm air unit heaters

Non-domestic warm air unit heaters (indirect-fired) use heat exchangers to transfer the heat from combustion to the air diffused into the room. Energy-efficient warm air unit heaters are equipped with direct driven fan motors, variable speed fans as well as modulating burners. Furthermore, these heaters have efficient heat exchangers generally made of galvanised steel. As a consequence, state-of-the-art indirect fired heaters achieve a net thermal efficiency of up to 93%<sup>16</sup> when operating at full load.

The efficiency level of warm air unit heaters may be increased further, if latent heat in the water vapour in flue gases is recovered. Condensing heat recovery is achieved by passing the flue gases through a corrosion resistant heat exchanger made of galvanised steel. Flue gases are cooled down below a certain temperature level causing the water vapour to condense and release its

<sup>15</sup> TECHNOTHERM International GmbH. Storage Floor Heating. [www.technotherm.de/eng/eng/index\\_pc\\_ie.htm](http://www.technotherm.de/eng/eng/index_pc_ie.htm)

<sup>16</sup> Based on stakeholders (CEN TC 180 WG 4) feedback and calculated using the Net Calorific Value of the fuel

latent heat. State-of-the-art indirect fired condensing heaters achieve a net thermal efficiency of up to 103%<sup>17</sup> when operating at full load.

The use of warm air unit heaters especially in buildings with high room heights (large indoor spaces) additional destratification fans can be used to reduce the temperature increase over the height of the heated space. Such devices can be considered part of the extended product. The influence of additional destratification fans on the performance of warm air unit heaters can be assessed by taking in to account the emission efficiency parameter  $\eta_{em,des}$ . The emission efficiency is in turn related to the specific air throw rate of the warm air heaters. The specific air throw is assessed as air volume blown by the heater (m<sup>3</sup>/h at 15 K temperature rise per kW heat in performance). The influence of seasonal variation of heat load on the specific air throw rate is calculated as per following:

***Seasonal specific air throw rate = 0.2 x Specific air throw rate<sub>maximum input</sub> + 0.8 x Specific air throw rate<sub>minimum input</sub>***

Lower the specific air throw rate the higher is the emission efficiency of the warm air heater for a application in a specific building. State-of-the-art warm air unit heaters have seasonal specific air throw rate values lower than 5 W/m<sup>3</sup>/hour. Factors for these values can be found in standard DIN V 18599-5:2011.

For warm air heaters, there might be a potential to reduce NO<sub>x</sub> emissions, but it is not possible to measure NO<sub>x</sub> emissions on site, and real-life emissions are widely influenced by local conditions and gas quality.

## 6.1.9 Radiant gas-fired heaters

### ► Luminous radiant heaters

State-of-the-art luminous heaters have a chamber to pre-heat the air gas mixture as well as a high temperature radiant lattice placed before the ceramic plaque or gauze. With this, highly efficient radiant heaters may achieve a radiant factor greater than 0.80<sup>17</sup>. State-of-the-art gas-fired luminous radiant heaters using a modulating burner can achieve a net thermal efficiency of up to 96% when operating at full load<sup>17</sup>.

For luminous heaters, the level of NO<sub>x</sub> emissions (under 50 mg/kWh) is determined by the basic design of the combustion system that is at the same time the heat exchanger (radiant surface). Chemical reaction at or in the radiant surface keeps combustion temperatures low, therefore NO<sub>x</sub>-emissions are very low. No option for further reduction was identified for luminous radiant heaters.

<sup>17</sup> Based on stakeholders (CEN TC 180 WG 4) feedback

Figure 6-7: Diagram of a luminous radiant heater<sup>18</sup>

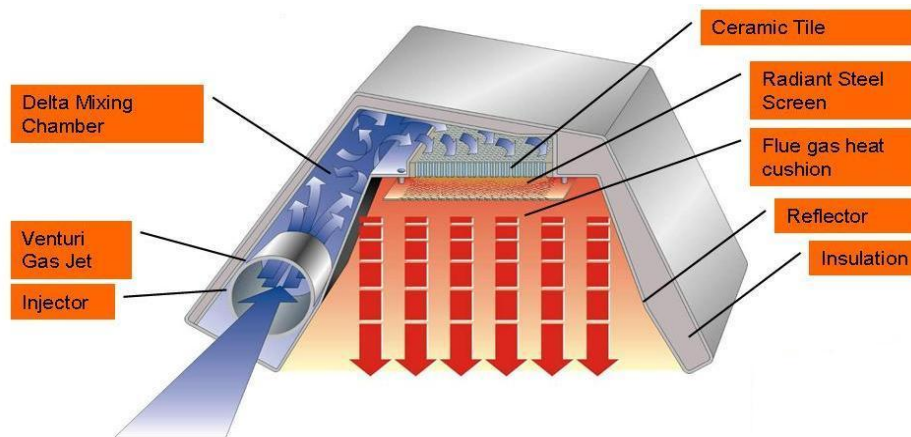

► Radiant tube heaters

Similar to luminous radiant heaters, highly efficient radiant tube heaters use fully modulating gas burners for firing the radiant tubes and a highly efficient insulation for the reflector. Figure 6-8 shows the difference between non-insulated radiant tube heaters and the well-insulated ones. Leading radiant tube heaters feature a radiant factor greater than 0.8<sup>17</sup>. State-of-the-art gas-fired radiant tube heaters using a modulating burner can achieve a net thermal efficiency of up to 94% when operating at full load<sup>17</sup>.

Optionally, these heaters can be connected to a waste heat recovery system in order to maximise the overall efficiency.

Figure 6-8: Reduction of heat losses achieved by insulation of heater<sup>19</sup>

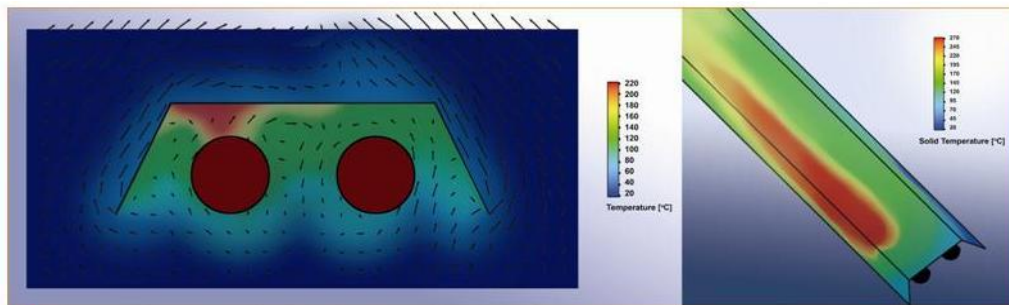

01 Temperature flow of a standard, non-insulated heater

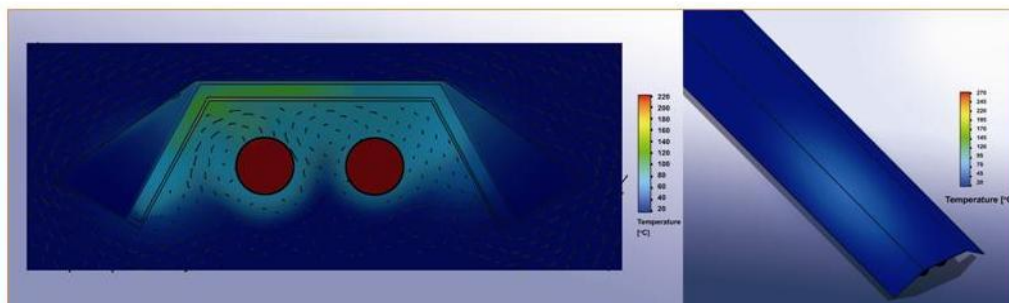

02 Temperature flow of an insulated heater minimizing the convective losses

<sup>18</sup> Schwank GmbH. The Principle of Luminous Heaters. [www.schwank.co.uk/en/ueber-schwank/downloads.html](http://www.schwank.co.uk/en/ueber-schwank/downloads.html)

<sup>19</sup> Schwank GmbH. superTube® brochure. [www.schwank.de/de/ueber-schwank/downloads.html](http://www.schwank.de/de/ueber-schwank/downloads.html)



Gas-fired radiant heating systems use a central controller to adjust each heating zone according to the actual heat demand. Each heating zone is controlled via a special radiant sensor that measures the operative room temperature (influenced by thermal radiation). According to the difference between the actual temperature and the desired temperature, the operation of the heating systems is adjusted. Modern devices are able to minimise the operating time by optimising the control of modulating burner devices. Self-adaptive components consider all individual usage patterns and optimise the control pattern accordingly. With modern control devices in combination with modulating burner technology, 14% of energy consumption can be saved and switching on/off can be reduced by 43% compared to single staged burner units.<sup>20</sup>

Figure 6-g: Diagram of a radiant sensor and central control device<sup>21</sup>

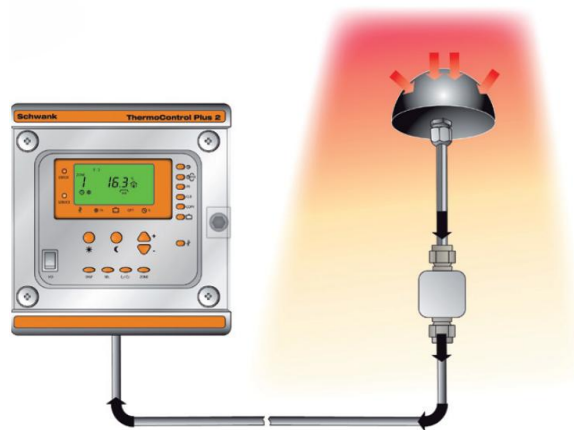

For radiant tube heaters, the level of NO<sub>x</sub> emissions (150 – 200 mg/kWh) is determined by the design of the combustion system inside the radiant tube that is also the heat exchanger (heat emitter). A long flame and high combustion temperatures are needed for good radiant and energy efficiency. Reducing NO<sub>x</sub> emissions further (e.g. by decreasing the flame length) will result in decreasing the efficiency of the product.

### 6.1.10 Air curtains

Air curtains aim to separate different climatic environmental at high frequented building entrances such as shops and factory buildings. It is therefore important to differentiate between the energy efficiency due to:

- Savings related to the energy consumed by the air curtain itself
- Savings related to reduced building heat losses from the opening (where the air curtain is installed)

Air curtains typically use hot water from (gas-fired) boilers as a heat source. Air curtains may also use heat pumps that offer energy consumption savings of up to 67% compared to conventional

<sup>20</sup> Schwank GmbH, ThermoControl Plus M brochure. [www.schwank.co.uk/en/ueber-schwank/downloads.html](http://www.schwank.co.uk/en/ueber-schwank/downloads.html)

<sup>21</sup> Schwank GmbH, ThermoControl Plus M brochure. [www.schwank.co.uk/en/ueber-schwank/downloads.html](http://www.schwank.co.uk/en/ueber-schwank/downloads.html)

systems<sup>22</sup>. Electric heated air curtains are also often used when there is no gas supply available at a premise.

Figure 6-10: Air curtain<sup>23</sup>

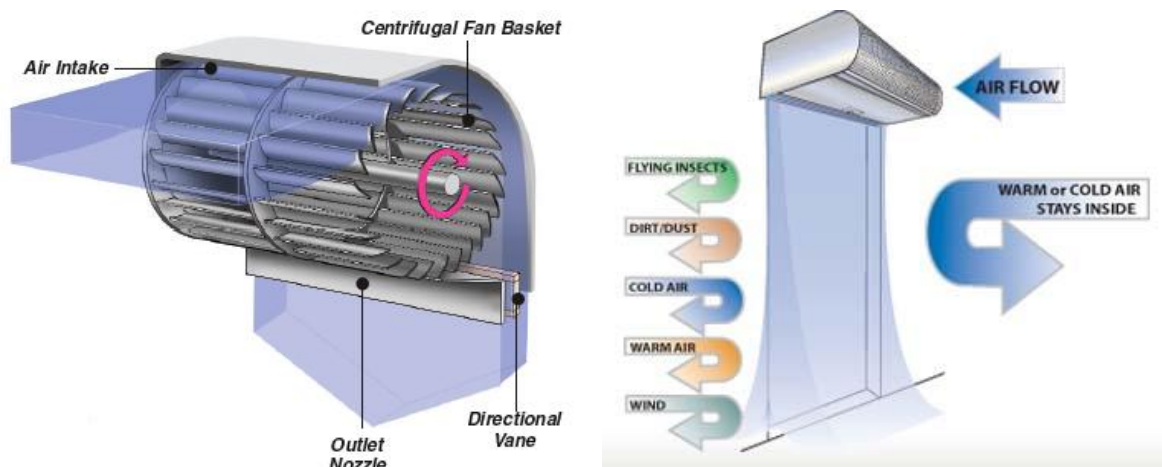

With regard to the energy efficient design of the product, variable speed fans<sup>24</sup>, air stream technology, timer delay function and event controlled operation (e.g. start-up in case of opening the door) represent state-of-the-art BATs.

Lower outside temperatures require more heating capacity to heat up the incoming cold in winter. In conventional air curtains the heating capacity is increased by increasing the discharge velocity. In air curtains with air stream technology the heating capacity is increased by increasing the jet width (the thickness of the air stream). Figure 6-11 demonstrates two cases of improving performance: higher discharge rate or wider air flow. The improved working of the air stream (CA) technology is demonstrated on the right.

<sup>22</sup> One UK based manufacturer remarked that the Carbon Trust in the UK is likely to introduce a gold standard with heat pump technology used to generate the heating energy. Similar to ECA, this will only concern the top 10% of units. The stakeholder further added that water heated air curtains using air to water heat pumps or even condensing boilers can provide similar and acceptable efficiencies.

<sup>23</sup> Berner International Corporation. What is an air door? [www.berner.com/univ\\_what.php5?top=1&sub=1](http://www.berner.com/univ_what.php5?top=1&sub=1)

<sup>24</sup> Fans were already covered in the scope of ENER LOT 11 and the resulting Regulation will have a significant impact on air curtains (as with all other equipment with fans). From 1 January 2013, the majority of air curtain manufacturers will have to change fans to comply with the requirements set under this Regulation. One stakeholder suggested that as an outcome, many air curtains will need to have EC/DC fan motors as from 1 January 2015 when the Second tier of minimum energy requirements takes effect.

Figure 6-11: Diagrams of the principles of conventional air curtains (increasing the discharge velocity) and air curtains using air stream technology (widening the air stream)<sup>25</sup>.

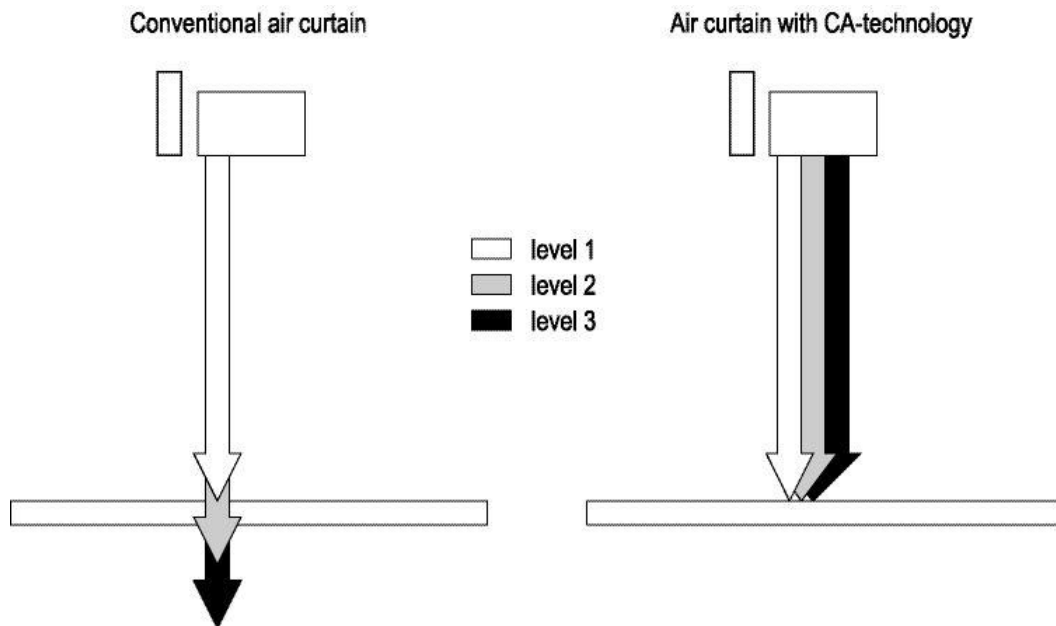

A high discharge velocity results in the air stream colliding with the floor surface, which makes it split into two parts. One part escapes to the outside area, which results in more heat lost. Thus, a high discharge velocity has a negative impact on the efficiency. It increases the turbulence of the air stream, which increases the heat losses of the air stream to the outside and thereby lowering the efficiency of climate separation even further.

Weather compensation controls can be used to automatically adjust the discharge air temperature in response to changes in the outdoor air temperature. By automatically reducing the heat output when it is not required (relative to the outdoor air temperature), this can result in energy savings regardless of the heating medium.

Air curtains equipped with air stream technology can save up to 30% of the energy losses through the air curtain opening compared to conventional air curtains<sup>26</sup>. State-of-the-art air curtains equipped with self-regulating controls consume up to 75% less energy and can save up to 60% of the energy losses through the air curtain opening compared to conventional air curtains<sup>26</sup>. In order to maintain high efficiency, manufacturers increase the heating capacity by widening the air stream making use of controlled air stream technology.

<sup>25</sup> Energy Saving through High Performance Climate Separation supported by Computational Fluid Dynamics simulations, Ir. P. Bethlehem, Biddle BV, Kootstertille, Prof. Dr. A.E.P. Veldman, University of Groningen

<sup>26</sup> Based on the feedback of a manufacturer of air curtains

## 6.2 State-of-the-art at component level

### 6.2.1 Heat generator

#### 6.2.1.1 *Electric heat generators*

Electric heating elements convert 100% of the electric energy into heat (Joule effect), therefore no major efficiency improvements are to be expected except for thermal insulation and the control units, which are elaborated in sections 6.2.3 and 6.2.4.

#### 6.2.1.2 *Gas Burners*

##### ▶ **Low-NO<sub>x</sub> burners**

In the past years, research and development for gas burners has strongly focused on the reduction of harmful NO<sub>x</sub> emissions that enhance photochemical ozone formation (smog) and nitrate accumulation in the ground. Significant improvements concerning thermal efficiencies are not to be expected.

Atmospheric burner for open/closed combustion gas fires are designed to produce long yellow flames, which must look as much as possible like a wood fire. Because of the wide/long yellow flame pattern, the flame temperatures are very low. This results in low NO<sub>x</sub> values (NO<sub>x</sub> levels of around 100 mg/kWh can be achieved).

The actual state-of-the-art solution for gas fired heaters is low-NO<sub>x</sub> gas surface burners that reduce the emission of NO<sub>x</sub> significantly. Nitrous oxides emission levels are mainly influenced by the combustion temperature, retention time and oxygen levels of the combustion air. For example, the formation of NO<sub>x</sub> rises exponentially above process temperatures of 1300 °C. As the biggest part of NO<sub>x</sub> is a result of such high temperatures, the primary measure is to lower the combustion temperature. This can be done in the following ways:

- Flame cooling using cooling rods is a technology that was used until the beginning of the 1990s and was replaced by premix burner technology. The flame cooling is achieved by installing cooling rods over the burner assembly. The rods take up heat from the core of the flames and emit thermal radiation to the combustion chamber walls. With cooling rods it is possible to reduce the NO<sub>x</sub> levels by approximately 30%.
- Premix burners provide a complete mixing of fuel and combustion air prior to the ignition takes place. As a result, a consistent combustion can take place in several smaller flame holders and thereby form a larger burner surface with lower flame temperature. With premixing burners it is possible to achieve NO<sub>x</sub> levels of less than 30 mg/kWh and CO levels of less than 5 mg/kWh. Premixing burners represent the state-of-the-art technology for gas burners.
- The principle of the premixing burner can be even more advanced than so-called surface burner technology that creates a large surface of tiny flames that hover closely over the flame holders or are even ignited inside and provide a uniform "flame-carpet".

- To further reduce the flame temperature, the burner surface is usually made of a special ceramic material that additionally improves the flame cooling effect and has good thermal radiation characteristics. This type of burner represents the state-of-art technology for gas-fired radiant heaters.<sup>27</sup>

Low-NO<sub>x</sub> and premix burners are readily available on the market, usually low-NO<sub>x</sub> burners are installed in open combustion/chimney connected flued gas heaters (BC 1), warm air heaters (BC 7); and premix burners are applied to gas-fired luminous and to radiant tube heaters (BC 8a and BC 8b). Low-NO<sub>x</sub> and premix burners cannot however be used for open combustion/chimney gas fires since they do not give the desired effect of a flame and also because of the noise produced by them.

#### ► Modulation

Power control of the heat generation system influences the ability of heaters to meet the actual heat demand of the building throughout the annual heating period. It also avoids additional energy losses from the building due to temporary or local overheating. As fuel consumption and energy efficiency are largely determined by the level of control of heating devices, modulating burners play a key role in this context. There are heaters with on/off, two stage and modulating power control on the market. Regarding atmospheric burners, modular operation is achieved through mechanical or pneumatic devices.

For non-residential warm air unit heaters, the impact of power control systems on energy efficiency can be expressed directly by considering the seasonally weighted heat generation efficiency of the heater with its load range. To gain relevant energy savings the turn down ratio of heaters should be at least 100-75% of the nominal heat input. State-of-the-art modulating burners can save up to 5% energy compared to on/off burners in BC 8b and up to 3% savings in BC 8a<sup>28</sup>.

#### ► Catalytic combustion

Catalytic combustion is a chemical reaction activated by using a catalyst whose characteristics do not alter with time. The reaction occurs between the gas fed to the heater and the oxygen from the surrounding atmosphere. The contact of these two elements, through the catalytic pad duly pre-heated, generates thermal energy. This gain of thermal energy is achieved without the presence of a flame. The reaction is exothermic and develops heat through infrared rays. Since no flame occurs, no harmful emissions are produced. Due to these reasons, catalytic combustion is used for gas-fired radiant heating systems.

The major advantages of catalytic combustion are:

- Flameless combustion leads to high quality gas combustion in total absence of a flame, as the catalyst activates the oxidation of the combustible at a temperature lower than its ignition temperature (400 K to 1000 K). Safe operation in potentially explosive atmospheres is possible.

<sup>27</sup> IKZ Haustechnik. Strobel Verlag. Issue 19/1997. Keramische Flächenbrenner in modulierenden Gas-Brennwertkesseln - Aufbau, Emissionen, Erfahrungen. Available at: [www.ikz.de/1996-2005/1997/19/9719035.php](http://www.ikz.de/1996-2005/1997/19/9719035.php)

<sup>28</sup> Stakeholder feedback from CEN TC 180 WG4 and independent manufacturers of gas-fired luminous radiant heaters

- Quick start-up: catalytic heaters are usually able to start-up in a very short time, shortening the pre-heating phase and consequently accelerating the operation time, and thereby also saving energy.
- Absence of CO, NO<sub>x</sub> and Unburned Hydrocarbons (HC): catalytic combustion generates exclusively carbon dioxide (CO<sub>2</sub>) and water vapour (H<sub>2</sub>O) without emission of carbon monoxide (CO), nitrogen oxides (NO<sub>x</sub>) and unburned hydrocarbons (HC).
- Modulating temperature: the temperature of the catalyst surface can be modulated by acting on the pressure of the gas: higher pressure results in shorter infrared ray's wavelength and, consequently, higher temperature<sup>29</sup>.

Catalytic burners are readily available on the market and are usually applied in open combustion/chimney connected flued gas heaters (BC 1) and warm air heaters (BC 7), but not in open combustion/chimney connected flued gas fires since catalytic burner gives no flame, which is needed for the decorative effect.

Catalytic burners allow quick start-up of the burner, flameless combustion, reduction of NO<sub>x</sub> emissions due to lower combustion temperature, as well as good capacity modulation and energy savings in part load mode.

#### ► Porous burner technology

Porous burners, which are also known as volume burners, burn an air-fuel mixture within a volumetric porous body, without the presence of a typical flame. This results in a considerable increase in the power density as well as lower emissions. In addition, the glowing reactor provides a higher degree of infrared radiation without creating any flame at the surface.

Porous burners can be operated with all conventional regulating devices for premixed combustion. There are no further or additional demands regarding operation or safety. Ignition takes place by means of an ignition electrode. Porous burners are thus well-suited for many industrial heating processes and are considered to be a future technology for the residential sector as well. First prototypes for residential use have been built already, but are still being researched.

---

<sup>29</sup> Infragas srl (2011) Technology page - catalytic combustion. [www.infragas.com/technology/index.html](http://www.infragas.com/technology/index.html)

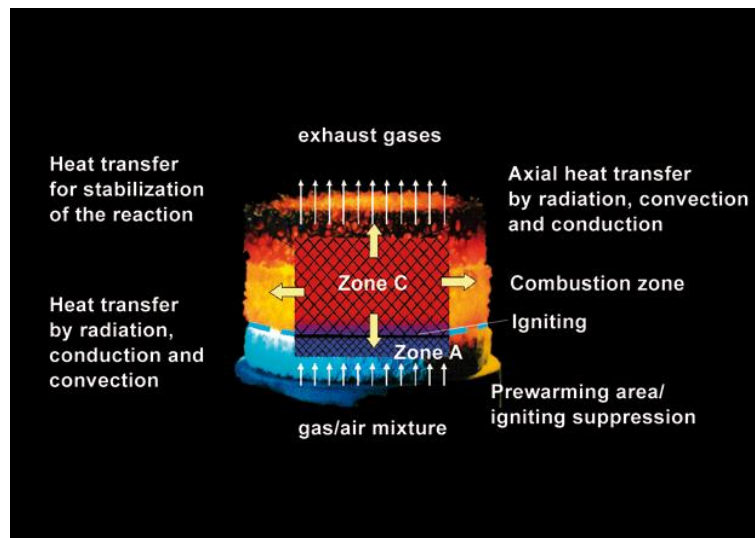
Figure 6-12: Porous combustion process<sup>30</sup>

Porous burner technology is being developed for open combustion/chimney connected flued gas heaters (BC 1) and warm air heaters (BC 7). Porous burner technology is not applied to open combustion/chimney connected flued gas fires since it does not give the desired decorative flame effect.

## 6.2.2 Ignition device

The heat loss from the burning pilot light can be eliminated by replacing the standard pilot flames with electric igniters.

Electric spark igniters provide a high voltage electrical spark between two electrodes. To do so, an electric transformer is required to generate a high electric voltage (approximately 12 000 V). The igniter is positioned close to the gas/oil flow that has to be lit. The generated spark is blown into the flowing fuel-vapour in an arc-shaped form. As the fuel stream should not touch the electrodes, the distance between the electrodes and the nozzle exit is of great importance. Electric spark igniters are predominantly used in higher capacity oil or gas burners.

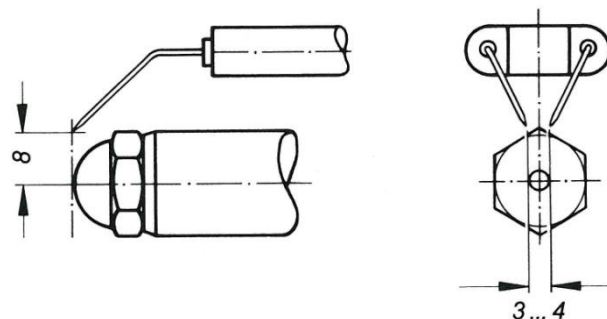
Figure 6-13: Electric spark igniter (oil burner)<sup>31</sup>

<sup>30</sup> Promeos GmbH. Porenbrennertechnologie. [www.promeos.com](http://www.promeos.com)

<sup>31</sup> Buderus Heiztechnik GmbH (2002) Handbuch für Heizungstechnik

A different type of electric igniter, which is especially relevant for smaller room heating devices is the piezo igniter. As the name suggest, piezo igniters work according to the piezoelectric effect, which is an electric charge that accumulates in certain solid materials (crystals, certain ceramics, etc.) in response to applied mechanical stress. The best-known application for piezo igniters is the electric lighter. Pressing the button causes a spring-loaded hammer to hit a piezoelectric crystal, producing a sufficiently high voltage electric current that flows across a small spark gap, thus heating and igniting the gas stream. The same kind of technology is used for lighting gas-fired local room heating products. Piezo igniters do not consume any kind of thermal energy or electricity, as the only input is mechanical energy. For this reason they represent the best available component for smaller capacity local room heating products.

Figure 6-14: Diagram of a piezo igniter in common lighter<sup>32</sup>

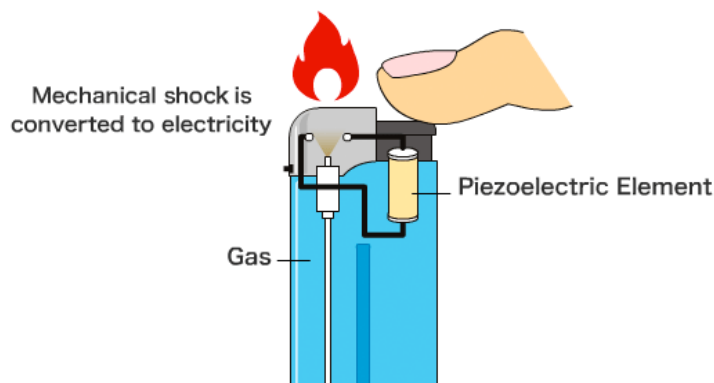

Electric spark and piezo igniters are common products on the market. Piezo ignition device can be used both in open combustion/chimney connected flued gas heaters and fires (BC 1 and BC 2)<sup>33</sup>. Both electric and piezo ignition systems allow avoiding the use of a pilot flame, in case of electric ignition just a small amount of energy will be required. However, it should be taken into account that no pilot flame system may cause corrosion and condensation issues for the heater<sup>34</sup>.

### 6.2.3 Thermal insulation of heaters

The influence of the thermal insulation is mostly determined by the construction of the building and the kind of installation. The thermal insulation is very important for the electric underfloor heating constructions performance and energy consumption as well as any other heating products. The floor should be thermally insulated according to how much energy the consumer wants to save and in proportion to how much thermal insulation the walls and ceiling have.

Contemporary best available electric underfloor heating products comprise thermally insulated material (e.g. polystyrene) in order to prevent energy losses. An underfloor heater manufacturer

<sup>32</sup> Kyocera Corporation. Characteristics of fine ceramics. Peizoelectricity.  
<http://global.kyocera.com/fcworld/charact/elect/piezo.html>

<sup>33</sup> One stakeholder (NHK - Dutch association for decorative fires and chimneys - The Netherlands) commented that for certain flued gas fires a pilot flame is still needed to have a safe ignition of the main burner as it depends on the design of the appliance.

<sup>34</sup> Stakeholder feedback (HHIC)



estimated 5% energy saving resulting from thermal insulation. For wooden or laminate floors, the BAT is a system which distributes the heat over the greatest surface area.

## 6.2.4 Controls

This section introduces various types of controls systems for local heaters. Controls represent a broad range of devices with particular variations for each type of heater. This chapter provides description of controls with their improvement potential for each type of appliance.

### ► Thermostat PI controller

Most local room heaters in this study are controlled by digital thermostats that are directly built into the room heater. However, thermostats built into the heater are too close to the heat source and therefore do not accurately measure the actual room temperature. Therefore, the BAT for the control of these heaters is a separate wall mounted programmable digital thermostats to ensure effective system control of the comfort temperature. These controllers can usually modulate the heat output according to the demand and have additional functions like timer mode.

Thermostat control systems with a high quality and accuracy are readily available on the market and could save up to 2-8% of energy consumption for space heating compared to electric heaters with manual on/off controls<sup>35</sup>.

Such controls can be built in to the heater or are part of the extended product as centralised zone controls with radio communication for individual temperature regulation of heaters in each room. These systems are cost effective and offer a short payback time.

These controls can be applied to open combustion/chimney connected flued gas heaters (BC 1), gas fires (BC 2), electric portable fan heaters (BC 3), fixed convector (BC 4), dynamic storage heaters (BC 5b), underfloor heating (BC 6a and BC 6b), warm air unit heaters (BC 7) and gas-fired radiant heaters (BC 8a and BC 8b). The main advantage of these systems is their precise thermostatic control (i.e. ability to accurately maintain the desired room temperature).

### ► Programmable thermostats

For local room heaters that contain a remote thermostat device, the best available control technology is a time programmable room thermostat, which combines a time switch and a room thermostat. This allows users to set different time periods with different target temperatures for space heating. A programmable thermostat could save up to 13% of energy consumption for space heating<sup>35</sup>.

These controls can be applied to open combustion/chimney connected flued gas heaters (BC 1), gas fires (BC 2), fixed convector (BC 4), dynamic storage heaters (BC 5b), underfloor heating (BC 6a and BC 6b), warm air unit heaters (BC 7) and gas-fired radiant heaters (BC 8a and BC 8b). The main advantage of these systems is precise thermostatic control.

### ► Automatic electric charge controller

---

<sup>35</sup> Feedback from manufacturers of fixed electric heaters.

Control systems for electric storage heaters contain an electric charge controller with an ambient temperature sensor and additional room thermostats. The best available technology enables a weather guided charge mechanism taking into account the residual charge of the storage heaters. The charging usually takes place during off-peak times (night time), as some electricity suppliers offer special reduced tariffs for this time period. The discharge of the stored thermal energy for dynamic storage heaters (BC 5b) is controlled by the room thermostats that are applied to the storage heaters.

Figure 6-15: Diagram of an electric storage heater control system<sup>36</sup>

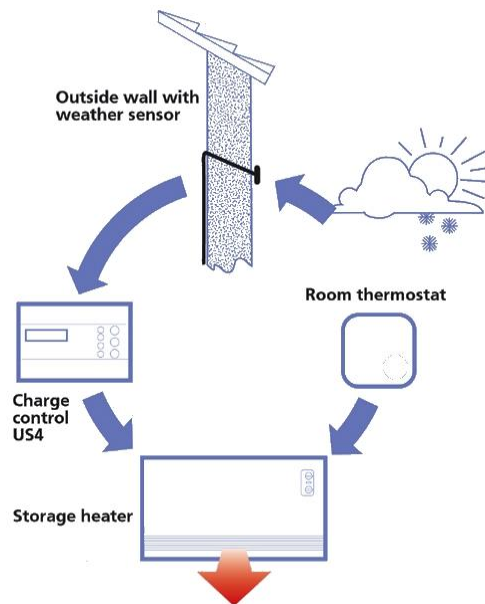

Existing controls for electric storage heaters (BC 5a and BC 5b) provide such functions as automatic electromechanical (BC 5a and BC 5b) and electronic charge controls (BC 5b). For dynamic storage heaters sophisticated controls also exist which can achieve more precise temperature control and have advanced algorithms for charging and discharging.

► **Open window detection sensors**

Real world data for open window detection savings has not been tested extensively. However, some stakeholders claim that assuming normal air changes are already taken into account, open window detection sensors can result in energy savings of 2-6%<sup>35</sup>.

## 6.2.5 Summary of BAT options at component level

In this section, the best available technology options at component level are summarised for each Base Case<sup>37</sup>.

<sup>36</sup> Olsberg Hermann Everken GmbH. Our electric heating range brochure. [www.olsberg.com/wDeutsch/heiz-und-lueftungssysteme/download\\_oeffentlich/inhalte/folder\\_export\\_english.pdf](http://www.olsberg.com/wDeutsch/heiz-und-lueftungssysteme/download_oeffentlich/inhalte/folder_export_english.pdf)

Table 6-1: Summary of BAT options for BC 1 (open combustion flued gas heater)

	BAT	Auxiliary energy consumption change [kWh]	Annual fuel consumption change [%]	Annual fuel consumption change [kWh]	Consumer price change [€]
Product level	Balanced flue	0	-19%	-343	200-300
	Eliminating pilot flame: electric ignition system	+1	-2%	- 37	10-20
	Mechanical draft	+1	-3%	- 55	10-20
Component level	PI controller	+1	-8%	-146	6
	Programmable thermostat with setback functionality	+1	-13%	- 238	30
	Absence detection	+1	-6%	-110	15
	Open window detection	+1	-6%	- 110	15

Table 6-2: Summary of BAT options for BC 2 (open combustion flued gas fire)

	BAT	Auxiliary energy consumption change [kWh]	Annual fuel consumption change [%]	Annual fuel consumption change [kWh]	Consumer price change [€]
Product level	Closed combustion: glass fronted	0	-35%	-1 001	100-150
	Balanced flue	0	-48%	-1344	200-300
	Eliminating pilot flame: electric ignition system	+1	-2%	-57	10-20
	Mechanical draft	+1	-3%	-85	10-20
Component level	PI controller	+1	-8%	-226	6
	Programmable thermostat with setback functionality	+1	-13%	-368	30
	Absence detection	+1	-6%	-170	15
	Open window detection	+1	-6%	-170	15

<sup>37</sup> Please note: all statements on improvement potentials for the different residential heating products (BC 1 to BC 6) and their BATs are based on estimations and have to be evaluated in combination with assumptions on building and/or user behaviour. At present, no applicable standards on the product level are available.

Table 6-3: Summary of BAT options at component level BC 3 (portable fan heater)

	BAT	Annual energy consumption change [%]	Annual energy consumption change [kWh]	Consumer price change [€]
Component level	On/off (two step) control	-80%	-266	3
	Thermostat - PI controller	-82%	-272	6

Table 6-4: Summary of BAT options for BC 4 (electric fixed convector)

	BAT	Annual energy consumption change [%]	Annual energy consumption change [kWh]	Consumer price change [€]
Component level	Thermostat - PI controller	-8%	-90	6
	Programmable thermostat with timer for multiple set points	-13%	-147	30
	Absence detection	-6%	-68	15
	Open window detection	-6%	-68	15
Product level	Single split reversible heat pump <sup>38</sup>	76%	-859	2 480

Table 6-5: Summary of BAT options at component level BC 5a (static storage heaters)

	BAT	Annual energy consumption change [%]	Annual energy consumption change [kWh]	Consumer price change [€]
Component level	Automatic (electromechanical) charge control	-5%	-65	20
	Automatic (electronic) charge control	-7%	-91	50-70

<sup>38</sup> Single split reversible heat pump having a capacity of 2.5 kW and COP (Coefficient of Performance) of 4. The single split reversible heat pump additionally requires installation cost of €1000 and annual maintenance and repair cost (for 12 years) of €60/year.

Table 6-6: Summary of BAT options at component level BC 5b (dynamic storage heaters)

	BAT	Annual energy consumption change [%]	Annual energy consumption change [kWh]	Consumer price change [€]
Component level	Automatic electronic charge control and thermostat output control	-10%	-131	60-100
	Sophisticated controls (advanced algorithms for charging and discharging)	-6%	-78	30-50

Table 6-7: Summary of BAT options at component level BC 6a (electric underfloor as primary heating)

	BAT	Annual energy consumption change [%]	Annual energy consumption change [kWh]	Consumer price change [€]
Component level	Thermostat - PI controller	-2%	-23	6
	Programmable thermostat with timer for multiple set points	-13%	-147	30
	Open window detection	-6%	-68	15

Table 6-8: Summary of BAT options at component level BC 6b (electric underfloor as secondary heating)

	BAT	Annual energy consumption change [%]	Annual energy consumption change [kWh]	Consumer price change [€]
Component level	Thermostat - PI controller	-2%	-3	6
	Programmable thermostat with timer for multiple set points	-13%	-17	30

Table 6-9: Summary of BAT options at component level BC 7 (warm air unit heater)

	BAT	Auxiliary energy consumption change [%]	Auxiliary energy consumption change [kWh]	Annual fuel consumption change [%]	Annual fuel consumption change [kWh]	Consumer price change [€]
Product level	Eliminating pilot flame: electric ignition system	0%	0	-2%	-800	200
	Combustion air supply: mechanical draft	+18%	+69	-3%	-1 200	200
	Generation efficiency	+12%	+46	-10%	-6 800	1600-2400
	Generation efficiency	+12%	+46	-13%	-7 767	1600-2400
	Emission eff./special air flow	+53%	+208	-10%	-4 167	1700
Component level	Thermostat on/off	0%	0	-6%	-2 222	80
	Automatic PI opt (time program)	0%	0	-14%	-5 656	400

Table 6-10: Summary of BAT options at component level BC 8a (radiant luminous gas heaters)

	BAT	Auxiliary energy consumption change [%]	Auxiliary energy consumption change [kWh]	Annual fuel consumption change [%]	Annual fuel consumption change [kWh]	Consumer price change [€]
Product level	Power control two stage	0%	0	-3%	-600	120
	Power control modulating	0%	0	-5%	-1 000	250
	Emission efficiency/Radiant factor > 0.65	0%	0	-14%	-2 800	500
	Emission efficiency/Radiant factor > 0.75	0%	0	-21%	-4 200	1100
Component level	Mechan./thermal evacuation type2	0%	0	-9%	-1 800	200
	Mechan./thermal evacuation type 3	+25%	+6	-11%	-2 200	350
	Thermostat on/off	0%	0	-6	-1 111	200
	RT automatic (time program)	25%	0	-12%	-2 474	250

Table 6-11: Summary of BAT options at component level BC 8b (radiant tube gas heaters)

	BAT	Auxiliary energy consumption change [%]	Auxiliary energy consumption change [kWh]	Annual fuel consumption change [%]	Annual fuel consumption change [kWh]	Consumer price change [€]
Product level	Power control two stage	0%	0	-3%	-900	120
	Power control modulating	0%	0	-5%	-1 500	400
	Generation efficiency (90%)	+20%	+18	-4%	-1 200	210
	Generation efficiency (92%)	+20%	+18	-6%	-1 800	400
	Emission efficiency/ Radiant factor >0.60	0%	0	-8%	-2 400	620
	Emission efficiency/ Radiant factor >0.70	0%	0	-15%	-4 500	1500
Component level	Thermostat on/off	0%	0	-6%	-1 667	80
	RT automatic (time program)	0%	0	-15%	-4 242	350

Table 6-12: Summary of BAT options at component level BC 9 (air curtains)

BAT	Auxiliary energy consumption change [%]	Auxiliary energy consumption change [kWh]	Annual fuel consumption change [%]	Annual fuel consumption change [kWh]	Building energy savings [%]	Building energy savings [kWh]	Consumer price change [€]
Controlled air stream technology	0%	0	0%	0.0	30%	2 870	150
Self-regulating controls	-50%	-169	-75%	-4 968	60%	5 741	375

### 6.3 State-of-the-art of best existing product technology outside the EU

Local room heating products – both residential and non-residential - available in the EU are essentially of similar design to appliances sold outside the EU. Therefore no different technologies have been identified outside the EU.

## 6.4 Conclusion and summary

The BATs and BNATs assessed in this chapter focused both on efficient heat generation technologies as well as advanced control options to effectively meet the required heat demand. In the case of gas and oil fired heaters potential energy savings are expected from more efficient burners, effective ignition devices, efficient heat emission and effective control systems. On the other hand, as the heat generation efficiency of electric heaters is 100%, energy savings for these heaters are mostly expected from the use of effective control systems (such as programmable thermostats and open window detection sensors) only. The energy savings resulting from a system perspective will include important parameters such as better insulation, higher internal and external heat gains. These are not analysed in this chapter as they are expected to have similar effects on the system level efficiency for all the heaters covered in this ENER Lot 20 study.

As the energy consumption during the use phase is the most dominant in terms of life cycle environmental impacts, the main contribution regarding local room heaters will be through improving the temperature control functions for all appliances within the group.





25 June 2012

20-22 Villa Deshayes  
75014 Paris  
+ 33 (0) 1 53 90 11 80  
[biois.com](http://biois.com)