

Ecodesign of Laundry Dryers
Preparatory studies for Ecodesign requirements
of Energy-using-Products (EuP) – Lot 16

Final Report
March 2009

This final report was prepared by **Ecobilan, PricewaterhouseCoopers'** Centre of Excellence for eco-design and environmental impact assessment of products and services¹ for and only for the European Commission of the European Communities, Directorate General for Energy and Transport, in accordance with the terms of reference of the call for tender TREN/D3/390/-2006 of 22 December 2006 and our service contract² dated 30 November 2007 and for no other purpose.

The final report including Tasks 1 to 8 was finalised on 31 March 2009 based on information, which was available to us as at that date, and following the comments sent by the Commission based on the final draft report version sent on 23 of December, 2008.

For any additional information about the Eco-design of Laundry dryers, you can also visit our project website: www.ecodryers.org

or contact us

ecodryers@fr.pwc.com

Clément Lefèvre
PricewaterhouseCoopers Advisory (France)
Sustainable Business Solutions
63, rue de Villiers
F-92208 Neuilly-sur-Seine
France
Tel. +33 1 56 57 89 78
Fax +33 1 56 57 16 36
clement.lefevre@fr.pwc.com

¹ in cooperation with **Conception Développement Durable Environnement (CODDE)** and **KERP Center of Excellence in Electronics & Environment**

² contract TREN/D3/390-2006/Lot 16/S07.77062, PwC reference: WBS-FR-00563209.001/ EAST 070111

Table of Contents

i	Introduction.....	27
i.1	Context of this project.....	27
	The European Directive on Eco-design of Energy-using Products.....	27
	The purpose of the preparatory study for laundry dryers.....	28
	The scope of the preparatory study for Laundry dryers.....	28
i.2	Organisation of the document.....	29
i.3	Planning of the project.....	29
	Continuous dialogue with stakeholders.....	31
I	Task 1: Definition.....	32
I.1	Product definition, standards and legislation (Task 1).....	33
I.1.1	Product definition.....	33
	Laundry dryers: general definition(s).....	33
	Product definitions for industry and commercial purposes.....	33
	Classification according to EU trade classifications.....	34
	Classification according to standards.....	35
	Functional and performance parameters.....	40
I.1.2	Existing standards.....	40
	International and European standards.....	41
	National standards.....	44
	Conclusion on standards.....	48
I.1.3	Existing legislation and voluntary initiatives.....	49
	European legislation.....	49
	Legislation outside the EU.....	51
	Voluntary initiatives.....	52
	Conclusion on legislation and voluntary initiatives.....	53
I.1.4	Preliminary scope of the project.....	54
	Annexes to Task 1.....	56
A	References.....	57
B	Summary of comments from stakeholders.....	59
C	Relevant existing standards.....	63
	The household dryer performance standards.....	63
	International standard IEC 61121 and European standard EN 61121.....	63
	European standard EN 1458.....	65
	The standard for household appliances airborne acoustical noise measurement.....	66
	International IEC 60704 and European standard EN 60704.....	66

The standard for household appliances standby power measurement	67
International IEC 62301 and European standard EN 62301	67
The standards on environmental issues	67
International standard IEC PAS.....	67
The future International standard IEC 62430 on eco design.....	68
D Relevant existing legislation	69
The EU Energy labelling.....	69
Directive 92/75/EEC, Directive 95/13/EEC, Directive 96/60/EEC	69
Conformity assessment and enforcement.....	72
Work in progress.....	72
Brief summary of other relevant Directives	73
Directive 2001/95/EC – The General Product Safety Directive.....	73
Directive 90/396/EEC – The Gas Appliance Directive	73
Directive 97/23/EEC – The Pressure Equipment Directive	74
Directive 2004/108/EC – The Electromagnetic Compatibility Directive.....	74
Directive 2006/95/EC – The Low Voltage Directive	74
Directive 2002/96/EC – The WEEE Directive.....	75
Directive 2002/95/EC - The RoHS Directive.....	75
Other national legislation and regulation.....	75
Australia	75
Canada	77
USA.....	78
New Zealand.....	80
E Voluntary initiatives	81
Australia.....	81
Chinese Taipei (Taiwan).....	81
UK.....	82
II Task 2: Economic and market data	84
II.1 Generic economic data.....	85
II.1.1 Drying machines market in Europe: production, import and export data	85
II.1.2 Commercial/professional dryers market.....	87
II.2 Market data for domestic dryers: sales analysis	88
II.2.1 Tumble dryers sales analysis	88
Methodological approach.....	88
Global trends from 2002 up to 2007 for the European tumble dryers market.....	88
Distribution of gas and electric tumble dryers sales in Europe.....	90
Electric tumble dryers sales.....	90
South West and North West European sales analysis.....	95

	Heat-pump tumble dryers	95
II.2.2	Washer-dryers sales.....	95
II.3	Market data: stock model	96
II.3.1	Stock estimation	96
	A dynamic stock model: methodology	96
	Past, actual and future stock estimation.....	98
II.3.2	Estimated sales	99
	New Input parameters	99
	Sales estimations.....	101
II.3.3	Market trends.....	102
II.4	Consumer expenditure base data	103
II.4.1	Consumer prices analysis.....	103
	Western Europe.....	103
	Eastern Europe.....	104
II.4.2	Energy prices.....	105
	Electricity prices.....	105
	Gas prices.....	106
II.4.3	Repair and maintenance costs	107
II.4.4	Disposal tariff/taxes, Recycling systems and costs.....	108
	Fares included in the consumer prices.....	108
	Six European recycling systems for Electric and Electronic Equipments	109
	Annexes to Task 2.....	111
F	References	112
G	Summary of comments from stakeholders	113
III	Task 3: Consumer behaviour and local infrastructure.....	117
III.1	Objectives and Methodology	118
III.1.1	Objectives	118
III.1.2	Methodology	118
	Manufacturer survey.....	118
	Consumer survey.....	119
III.1.3	Scope of the surveys	119
	Participants to the consumer survey	119
	Participants to the manufacturer survey.....	121
III.1.4	Analysis of the results.....	121
III.2	General results	123
III.2.1	Living conditions of the consumers surveyed.....	123
	Dwelling type	123

Household size	124
Sharing a dryer	124
III.2.2 Characterization of the stock of dryers	125
Location	125
Type of dryers and loading possibilities.....	127
Capacity of dryers	131
Type of control	131
Energy efficiency class of dryers	132
Purchase price	134
Age of dryers	134
Length of a dryer cycle	135
III.3 Declared consumer behaviour.....	136
III.3.1 Drying habits	136
In summer	136
In winter	139
III.3.2 Frequency of use	141
In summer	141
In winter	142
III.3.3 Choice of program	143
Washing machine spin speed.....	143
Drying programme	145
"Reduced iron" programme	146
III.3.4 Load and loading habits.....	146
Load.....	146
Loading habits	147
III.3.5 Attitude towards dryer options	147
Start and end of programme.....	148
Use of consumables	151
Cleaning of components	151
III.3.6 After the drying phase: ironing or not?	152
III.3.7 Buying decision.....	153
III.3.8 Attitude towards energy and environmental issues	156
Towards energy	156
Towards environmental issues	157
III.4 End-of-Life Behaviour.....	160
III.4.1 Actual time to disposal.....	160
III.4.2 Repair and Maintenance.....	160
III.4.3 Estimated second hand use	161
III.5 Local infrastructure.....	163

III.5.1	Availability and nature of energy	163
	For electric appliances.....	163
	For gas tumble dryers.....	163
III.5.2	Special energy tariffs	163
III.5.3	Physical environment.....	163
III.6	Elements for comparison between declared real life and standard conditions	164
III.7	Conclusion	166
	Annexes to Task 3.....	168
H	References	169
I	Summary of comments from stakeholders	170
J	Questionnaires	175
	Consumer questionnaire	175
	Manufacturer questionnaire.....	181
IV	Task 4: Technical analysis of existing products	189
IV.1	Objective and methodology	190
IV.2	Production phase	191
IV.2.1	Air vented tumble dryers.....	191
	Technical description	191
	Bill of Materials	199
	Specific case: a “compact” air vented tumble dryer	201
IV.2.2	Condenser tumble dryers	202
	Technical description	203
	Bill of Materials	206
	Specific case: a “top loading” air condenser tumble dryer	208
IV.3	Distribution phase.....	211
IV.4	Use phase (Product)	212
IV.4.1	Key aspects of the drying process.....	212
	Some key definitions.....	212
	Water vaporization	212
	Application to the air vented tumble dryer	215
	Application to the air condenser tumble dryer	217
IV.4.2	Internal factors influencing the energy consumption	218
	Case of air vented tumble dryers.....	218
	Case of air condenser tumble dryers.....	219
	Special remark on control strategy	220
IV.4.3	Energy consumption of laundry dryers	220

Standard and real life conditions	220
Proposal of a correction factor to calculate energy consumption under real life conditions ..	222
Average duration of a drying cycle under real life conditions	222
Energy consumption of an air vented tumble dryer	223
Energy consumption of a condenser tumble dryer	223
Energy consumption: breakdown per main components / subparts	224
IV.5 Use phase (System)	225
IV.5.1 External factors influencing the energy consumption	225
Types of fabrics	225
Loading of the dryer	225
The spin speed of the washing machine	225
Ambient air humidity	226
Ambient air temperature	227
Customer behaviour	227
IV.5.2 Modelling use phase considering atmospheric parameters	228
General results for energy demand (energy consumption)	229
Sensitivity analyses	229
IV.6 End of life phase.....	231
Annexes to Task 4	238
K References	239
L Summary of comments from stakeholders	240
M Energy efficiency scale for tumble dryers.....	242
V Task 5: Definition of base case.....	243
V.1 Definition of Base Cases	244
V.1.1 Standard Base Cases definition	245
V.1.2 Real Life Base Cases definition.....	246
V.2 Product-specific inputs (Subtask 5.2).....	248
V.2.1 Principles	248
V.2.2 General assumptions.....	248
V.2.3 BOM and Inventory Data Collection for air vented dryers	249
BOM.....	249
Distribution	251
Use.....	251
V.2.4 BOM and Inventory Data Collection for air condenser tumble dryers	253
BOM.....	253
Distribution	254
Use.....	254

V.3	Base Case Environmental Impact Assessment (Subtask 5.3)	256
V.3.1	Environmental impact assessment of the Base Case air vented tumble dryer using the EuP-EcoReport	257
	Energy consumption distribution over the whole life cycle	257
	Influence of the different life cycle phases on the air and water impact indicators	259
	Influence of the manufacturing phase on the environmental impact assessment.....	260
	Sensitivity analysis for compact air vented tumble dryers.....	262
V.3.2	Environmental impact assessment of the Base Case air condenser tumble dryer using the EuP EcoReport.....	265
	Distribution of the energy consumption over the life cycle of the product	265
	Influence of the different life cycle phases on the air and water impact indicators	267
	Influence of the manufacturing phase on the environmental assessment	269
	Sensitivity analysis for top condenser tumble dryers	270
V.3.3	Preliminary conclusions	272
V.4	Base Case Life Cycle Costs (Subtask 5.4)	274
V.4.1	LCC for the Base Case air vented tumble dryer.....	274
	Key technical and financial assumptions.....	274
	Analysis of the results for the Base Case air vented tumble dryer.....	276
	Sensitivity analysis for compact air vented tumble dryers.....	277
V.4.2	LCC for the Base Case condenser tumble dryer.....	278
	Key technical and financial assumptions.....	278
	Analysis of the results for the Base Case condenser tumble dryer.....	279
	Sensitivity analysis for top condenser tumble dryers	280
V.4.3	Preliminary conclusions	281
V.5	EU Totals (Subtask 5.5)	282
V.5.1	EU total environmental assessment of air vented tumble dryers	282
V.5.2	EU total environmental assessment of condenser tumble dryers	284
	Annexes to Task 5	286
N	References	287
O	Summary of comments from stakeholders	288
VI	Task 6: Technical analysis of Best Available Technology (BAT)	290
VI.1	State of the art already on the market (product level)	291
VI.1.1	Information collection.....	291
VI.1.2	Best available technologies on the market (product level)	291
	Vented tumble dryers.....	292
	Condenser tumble dryers	294
	External heat source dryers.....	296

VI.1.3	Best Available Technologies outside the EU (product level).....	297
VI.2	State of the art (component level)	298
VI.2.1	Best available Technologies (component level)	298
	Casing and door	298
	Motor.....	298
	Drum	299
	Resistive heating element.....	299
	Burner	300
	Air inlets, outlets, and tubing	300
	Condensate reservoir	301
	Refrigerants	301
	Heat exchanger	301
	Heat pump	302
	Control features	302
	Water inlets, outlets, and tubing	303
	Programmes available	304
	User interface	304
	User behaviour	304
VI.3	Potential application for the base cases - List of design options.....	305
VI.3.1	Proposed design options	305
VI.3.2	Combinations of design options	307
	Rationale for combination	307
VI.4	Best Non Available Technologies	309
VI.4.1	Best Non Available Technologies (product level).....	309
	Modulating gas dryers	309
	Microwave dryers.....	310
	Vacuum dryers.....	312
	Mechanical steam compressor dryers.....	312
VI.4.2	Best Non Available Technologies outside the EU (component level)	314
VI.4.3	Best Non Available Technologies (component level)	314
VI.5	Conclusion	315
	Annexes to Task 6	316
P	References	317
Q	Summary of comments from stakeholders	318
VII	Task 7: Improvement potential	321
VII.1	Objectives	322

VII.2	Improvement options	323
VII.2.1	Common improvement options for both base cases.....	325
	Improved insulation.....	325
	Combined drying programme.....	326
	Sensor improvement – Load control.....	326
	Sensor improvement – Intelligent load control.....	327
VII.2.2	Improvement options for Air vented dryers.....	327
	Heat pump technology for vented dryers (Option 1).....	328
	Gas dryers (Option 2).....	328
	Exhaust air heat recovery (Option 3).....	330
	Optimized process and system design (Option 4).....	331
	Improved motor concept (incl. control) (Option 5).....	331
	Heat recovery motor (Option 6).....	331
	Mix airflow system (Option 8).....	332
	Comparison of the improvement options for air vented dryers and conclusions.....	332
	Comparison conclusions.....	335
VII.2.3	Improvement options for Air condenser dryers.....	337
	Heat pump condenser dryers (Option 1).....	337
	Optimized process and system design (Option 2).....	340
	Improved motor concept (incl. control) (Option 3).....	340
	Heat recovery motor (Option 4).....	340
	Comparison of the improvement options for air condenser dryers and conclusions.....	341
	Comparison conclusions.....	343
VII.3	LLCC and BAT analyses	346
VII.3.1	Base case Air vented dryer.....	346
	Individual improvement options.....	346
	Effect of cumulative options for vented dryers.....	351
VII.3.2	Base case Air condenser dryer.....	355
	Individual improvement options.....	355
	Effect of cumulative options for condenser dryers.....	360
VII.4	Conclusions	365
	Annexes to Task 7	367
R	References	368
S	Summary of comments from stakeholders	369
T	Ecoreport results for improvement options	372
VIII	Task 8: Scenario-, policy-, impact- and sensitivity analysis	382
VIII.1	Policy review	383

VIII.1.1	Global overview of policy instruments in place worldwide to foster the environmental performance of energy using products.....	383
VIII.1.2	Existing policy measures in Europe and outside Europe	384
	Labels	384
	Voluntary initiatives.....	388
	Financial policy instruments	388
	Information programmes.....	389
VIII.2	Policy measures considered.....	390
VIII.2.1	Minimum Energy Performance Standards (MEPS).....	390
VIII.2.2	Labels	390
	Mandatory comparative EU Energy label.....	390
VIII.2.3	Voluntary initiatives.....	391
VIII.2.4	Financial incentives	391
	Information programmes.....	392
VIII.3	Scenario analysis	393
VIII.3.1	General hypotheses.....	393
VIII.3.2	Scenario-specific hypotheses.....	396
VIII.3.3	Scenario analysis.....	398
VIII.4	Impact on manufacturers and consumers.....	401
VIII.4.1	Impact on manufacturers.....	401
VIII.4.2	Impact on consumers	401
VIII.5	Sensitivity analysis of main parameters.....	402
VIII.5.1	Local systems.....	402
VIII.5.2	Assumptions on costs.....	402
VIII.5.3	Assumptions on the penetration rate.....	405
	Annexes to Task 8.....	409
U	References	410
V	Summary of comments from stakeholders	411
W	CECED proposal for MEPS and a new tumble dryer label.....	412
X	S.A.F.E. proposal for a new tumble dryer label.....	417
Y	Detailed scenario analysis results	419
	Annexes to the final report.....	421
Z	Minutes of the first stakeholders meeting (Brussels, 3 March 2008)	422
	Agenda.....	422
	Summary of discussion	422
	List of participants	425

AA	Minutes of the second stakeholders meeting (Brussels, 6 June 2008)	426
	Agenda	426
	Summary of discussion	426
	List of participants	428
BB	Final meeting with stakeholders (Brussels, 12 December 2008)	430
	Final meeting with stakeholders, on the Preparatory Study for Ecodesign Requirements of Energy-using-Products (EuP) - Laundry dryers (lot 16) for the European Commission (DG-TREN).....	430
	Agenda	430
	Summary of discussion	430
	Task 1	430
	Task 2-3	430
	Task 4-5	430
	Task 6	431
	Task 7	431
	Conclusion and next steps	431
	List of participants	432

Table of Figures

Figure 1: Planning of the project	30
Figure 2: Electric air vented tumble dryer	37
Figure 3. Electric condenser tumble dryer (air condenser dryer)	38
Figure 4: Overview of product types of existing electric tumble dryers	39
Figure 5: Overview of types of laundry dryers identified	40
Figure 6: Energy label for electric tumble dryers (left) and washer dryers (right)	70
Figure 7: Flow diagram of analyses for the U.S. residential clothes dryers energy standards rulemaking process	79
Figure 8: Tumble dryers sales in Europe, 2002 to 2007	89
Figure 9: Sales distribution by loading capacity	93
Figure 10: Sales distribution by energy efficiency classes, Western Europe	94
Figure 11: Stock evolution predicted up to 2020 for EU15	99
Figure 12: Stock evolution predicted up to 2020 for “new” incoming countries	99
Figure 13: Drying machine Lifespan normal distribution	100
Figure 14: Drying machine Remain function	100
Figure 15: Prices comparison 2002 vs. 2005 by energy efficiency classes	104
Figure 16: Recycling rates of existing European disposal systems for electric and electronic equipments	109
Figure 17: Economic costs of existing European disposal systems for electric and electronic equipments	110
Figure 18: Age of the interviewed persons	121
Figure 19: Gender of the interviewed persons	121
Figure 20: Dwelling type of the interviewed persons	123
Figure 21: Living situation by country	123
Figure 22: Number of household members	124
Figure 23: Number of household members by country	124
Figure 24: Number of households sharing one dryer	125
Figure 25: Reasons for sharing a dryer	125
Figure 26: Dryer location at home (weighted results)	126
Figure 27: Main locations of laundry dryers (according manufacturers)	126
Figure 28 Ventilation of the space where the dryer is located	127
Figure 29: Type of dryer technology (weighted results)	127
Figure 30: Type of dryer by country: technology	128
Figure 31 Type of loading (weighted results)	129
Figure 32: Type of dryer by country: laundry loading	129
Figure 33 Capacity of the dryer (weighted results)	131
Figure 34: Run time control (weighted results)	132

Figure 35: Runtime control by country	132
Figure 36: Energy class of dryers (weighted result).....	133
Figure 37: Purchase price of dryer	134
Figure 38: Age of dryers (weighted results)	135
Figure 39: Length of a dryer cycle (weighted results)	135
Figure 40: Average load by drying time (weighted results).....	135
Figure 41: Drying laundry in summer	136
Figure 42: Drying laundry in summer (UK).....	137
Figure 43: Drying laundry in summer (FR).....	137
Figure 44: Drying laundry in summer (PL)	138
Figure 45: Drying laundry in winter.....	139
Figure 46: Drying laundry in winter (UK)	140
Figure 47: Drying laundry in winter (FR)	140
Figure 48: Drying laundry in winter (PL).....	141
Figure 49: Number of cycles per week used in summer	142
Figure 50: Number of cycle per week (summer) by number of household members	142
Figure 51: Number of cycles per week used in winter	143
Figure 52: Number of cycle per week (winter) by number of household members	143
Figure 53: Washing spin speed (rpm) used before drying	144
Figure 54: Distribution of the most selected drying programs.....	145
Figure 55: Distribution of common used dry programs (special study).....	145
Figure 56: Average loading (kg) (weighted results)	146
Figure 57: Loading behaviour of consumers (weighted result)	147
Figure 58: Options most frequently used	148
Figure 59: Ratio of dryers with a power switch	148
Figure 60: Use of the switch off button of the dryer.....	149
Figure 61: Distribution of the amount of start delay (weighted results).....	150
Figure 62: Time until unload the dryer and turn off the button	151
Figure 63: Use of consumables.....	151
Figure 64: Cleaning of the fluff filter	152
Figure 65: Cleaning of the heat exchanger (in case of air condenser dryer).....	152
Figure 66: Consumer behaviour with the dry laundry	153
Figure 67: Ironing program usually used.....	153
Figure 68: Consumer buying decision criteria on general aspects (according to manufacturers) .	154
Figure 69: Consumer buying decision criteria on environmental aspects (according to manufacturers)	154
Figure 70: Consumer buying decision criteria on several aspects (according to consumers).....	155
Figure 71: Payback period considered by the consumer for buying decision.....	156
Figure 72: Consumers opinion about the influence of appliances on the overall energy consumption of a household	156

Figure 73: Information channels for consumers regarding environmental issues (according to manufacturers)	157
Figure 74: Information channels for environmental issues (according to consumers).....	158
Figure 75: Consumer information ways on several kinds of environmental Figures (according to manufacturers)	158
Figure 76: Information on environmental issues for sales people (according to manufacturers) ..	159
Figure 77: Scenarios for the disposal of an old dryer.....	160
Figure 78: Envisaged reparation of the dryer.....	161
Figure 79: Proportion of repaired or serviced appliances	161
Figure 80: Proportion of second hand appliances.....	162
Figure 81: Picture of an air vented tumble dryer (Front)	191
Figure 82: Air vented tumble dryer (Front) – Components and function.....	192
Figure 83: Drum of an air vented dryer (Front)	192
Figure 84: Drum of an air vented dryer (Front)	193
Figure 85: Motor and fan	193
Figure 86: Sheathed element heater.....	194
Figure 87: Open coils heating element	195
Figure 88: Single flat surface filter.....	195
Figure 89: Time control	196
Figure 90: Cycle programmer.....	197
Figure 91: Linen conductivity sensor.....	197
Figure 92: Carbon brush	197
Figure 93: User interface with touch screen.....	198
Figure 94: User interface with LCD display panel.....	198
Figure 95: User interface with LED	198
Figure 96: User interface with simple time control (mono-command).....	198
Figure 97: Drum of a compact tumble dryer.....	201
Figure 98: Motor and fan of a compact tumble dryer	201
Figure 99: Pictures of an air condenser tumble dryer (Front)	202
Figure 100: Air condenser tumble dryer – Components and function.....	203
Figure 101: Condenser motor	204
Figure 102: Heat exchanger.....	204
Figure 103: Condensate reservoir.....	205
Figure 104: Hinged V-shaped filter.....	205
Figure 105: Drawing of the drum of a top loading condenser tumble dryer.....	208
Figure 106: Type of packaging of a laundry dryer.....	211
Figure 107 Abacus	215
Figure 108: Air flows in the air vented tumble dryer.....	215
Figure 109: Theoretical variation of the enthalpy between 1 and 2 means for the heating of ambient air.....	216

Figure 110: Variation of the enthalpy between 2 and 3, when the dry air goes through the tumble	216
Figure 111: Air flows in the air condenser tumble dryer.....	217
Figure 112: Thermodynamic cycle of an air condenser tumble dryer	218
Figure 113: Energy flows in an open circuit tumble dryer (air vented).....	218
Figure 114: Energy flows in a closed circuit tumble dryer (condenser)	219
Figure 115: Influence of the ambient temperature on the energy consumption of dryers.	227
Figure 116: Dryer use inside or outside heated rooms	228
Figure 117: Weight ratio of the materials of an air condenser tumble dryer	231
Figure 118: Used washing machines and laundry dryers	233
Figure 119: Removed cables	233
Figure 120: Removed capacitors	233
Figure 121: Desintegrator for household appliances	234
Figure 122: Cleaning up of shredded equipment.....	234
Figure 123: Granulator (to shred elements in small pieces)	235
Figure 124: A- The light part is sucked in.....	235
Figure 125: B- The heavy part falls on the treadmill	235
Figure 126: Densimetric sorting (vibrating table – dry way)	236
Figure 127: Rubble parts.....	236
Figure 128: Plastic parts.....	237
Figure 129: Densimetric sorting of plastic parts (wet way)	237
Figure 130: Energy consumption over all life cycle phases (GER in MJ) (STBS and RLBC Air vented).....	258
Figure 131: Energy consumption over the life cycle phases (excluding the use phase) (STBC Air vented).....	258
Figure 132: Electricity consumption over all life cycle phases (STBC and RLBC Air vented)	259
Figure 133: Electricity consumption over the life cycle phases (excluding the use phase) (STBC Air vented).....	259
Figure 134: Relative impact of the life cycle phases on air pollution (RLBC Air vented)	260
Figure 135: Relative impact of the life cycle phases on waste production and water pollution (RLBC Air vented)	260
Figure 136: Relative impact of the different types of steel	261
Figure 137: Contribution of the main materials to air and water pollution during the production phase.....	262
Figure 138: Relative contribution of the life cycle phases on the environmental impacts under standard conditions (Compact air vented)	264
Figure 139: Comparison between the Base Case air vented dryer and the compact air vented tumble dryer.....	264
Figure 140: Energy consumption over all life cycle phases (STBC and RLBC Condenser)	266

Figure 141: Energy consumption over the different life cycle phases (excluding the use phase) (RLBC Condenser)	266
Figure 142: Electricity consumption over all life cycle phases (STBC and RLBC Condenser)	267
Figure 143: Electricity consumption over the different life cycle phases (excluding the use phase) (RLBC Condenser)	267
Figure 144: Relative contribution of the life cycle phases on the environmental impacts under standard conditions (RLBC Condenser)	268
Figure 145: Relative impact of the life cycle phases on water pollution and on waste production (RLBC Condenser)	268
Figure 146: Contribution of the main materials to air and water pollution during the production phase	269
Figure 147: Relative contribution of the life cycle phases on the environmental impacts under standard conditions (STBC Top air condenser)	271
Figure 148: Comparison between the Base Case condenser dryer and the top condenser dryer	272
Figure 149: Comparison between the Base Case condenser dryer and the Base case Air Vented Dryer (Consumption & Wastes).....	273
Figure 150: Comparison between the Base Case condenser dryer and the Base case Air Vented Dryer (Emission to air).....	273
Figure 151: Comparison between the Base Case condenser dryer and the Base case Air Vented Dryer (Emission to water).....	273
Figure 152: Air vented tumble dryer	293
Figure 153: Condenser dryer	295
Figure 154: Heat pump tumble dryer principle	295
Figure 155: Laundry resistance vs humidity.....	303
Figure 156: Working principle of laundry resistance measurement.....	303
Figure 157: Energy labelling of laundry dryers.....	305
Figure 158: Microwave dryer principle	310
Figure 159: Transport of thermal energy in conventional and microwave dryers	310
Figure 160: Prototype countertop microwave dryer	312
Figure 161: Phase diagram showing the aggregate states of water as a function of pressure and temperature	312
Figure 162: Mechanical steam compression drying principle	313
Figure 163: Impact repartition during the whole life cycle of gas dryer.....	329
Figure 164: Comparison of the different options with the standard air vented dryer base case as reference (resources & wastes)	333
Figure 165: Comparison of the different options with the standard air vented dryer base case as reference (emissions to air).....	333
Figure 166: Comparison of the different options with the standard air vented dryer base case as reference (emissions to water).....	334

Figure 167: Comparison of the different options with the real life air vented dryer base case as reference (resources & wastes) 335

Figure 168: Comparison of the different options with the real life air vented dryer base case as reference (emission to air)..... 336

Figure 169: Comparison of the different options with the real life air vented dryer base case as reference (emission to air)..... 336

Figure 170: Impact repartition during the whole life cycle of a heat pump condenser dryer..... 338

Figure 171: Comparison of the different options with the standard air condenser dryer base case as reference (resources & wastes) 341

Figure 172: Comparison of the different options with the air standard air condenser dryer base case as reference (air emissions) 342

Figure 173: Comparison of the different options with the standard air condenser dryer base case as reference (water emissions) 342

Figure 174: Comparison of the different options with real life air condenser dryer base case as reference (resources & wastes) 344

Figure 175: Comparison of the different options with the real life air condenser dryer base case as reference (air emissions)..... 344

Figure 176: Comparison of the different options with the real life air condenser dryer base case as reference (water emissions) 345

Figure 177 LCC Curve- Environmental performance expressed in total electricity costs for the full load vented base case 348

Figure 178 LCC Curve- Environmental performance expressed in total electricity costs for the partial load vented base case..... 349

Figure 179 LCC Curve- Environmental performance expressed in total energy consumption for the full load vented base case 349

Figure 180 LCC Curve- Environmental performance expressed in total energy consumption for the partial load vented base case..... 350

Figure 181: LCC Curve - Environmental performance expressed in GWP for the full load vented base case 350

Figure 182: LCC Curve - Environmental performance expressed in GWP for the partial load vented base case 350

Figure 183: LCC Curve; environmental performance expressed in total electricity costs for the vented base case cumulating options 352

Figure 184: LCC Curve; environmental performance expressed in GWP for the vented base case cumulating options 352

Figure 185: LCC Curve; environmental performance expressed in GER for the vented base case cumulating options 352

Figure 186: Comparison of the cumulative options (resources & waste) for the base case air vented dryer (ranking by LCC) 353

Figure 187: Comparison of the cumulative options (emission to air) for the base case air vented dryer (ranking by LCC)	353
Figure 188: Comparison of the cumulative options (emission to water) for the base case air vented dryer (ranking by LCC)	354
Figure 189: LCC Curve; environmental performance expressed in total electricity costs for the full load condenser base case	358
Figure 190: LCC Curve; environmental performance expressed in total electricity costs for the partial load condenser base case	358
Figure 191 LCC Curve; environmental performance expressed in total energy consumption for the full load condenser base case.....	359
Figure 192: LCC Curve; environmental performance expressed in total energy consumption for the partial load condenser base case	359
Figure 193: LCC Curve; environmental performance expressed in GWP for the full load condenser base case	360
Figure 194: LCC Curve; environmental performance expressed in GWP for the partial load condenser base case	360
Figure 195: LCC Curve; environmental performance expressed in total electricity costs for the condenser base case cumulating options	361
Figure 196: LCC Curve; environmental performance expressed in GWP for the condenser base case cumulating options.....	362
Figure 197: LCC Curve; environmental performance expressed in GER for the condenser base case cumulating options.....	362
Figure 198: Comparison of the cumulative options (resources & waste) for the base case condenser dryer.....	362
Figure 199: Comparison of the cumulative options (emission to air) for the base case condenser dryer	363
Figure 200: Comparison of the cumulative options (emission to water) for the base case condenser dryer	363
Figure 201: General comparison of the 5 most energy effective options	365
Figure 202 : MEPS and labels, an illustration of market "push" and "pull"	384
Figure 203: Scenario analysis.....	399
Figure 204: Sensitivity analysis on the penetration rate	406
Figure 205: Scenario analysis, assuming a 40 % penetration rate.....	407

Table of Tables

Table 1: Extract from HS Classification.....	34
Table 2: Extract from PRODCOM List 2007	35
Table 3: Energy efficiency classes for air-vented tumble dryers.....	71
Table 4: Energy efficiency classes for condenser tumble dryers.....	71
Table 5: Energy efficiency classes for washer dryers	71
Table 6: Minimum energy performance levels for clothes dryers in Canada.....	77
Table 7: Minimum energy performance levels for clothes dryers in the U.S.A.	78
Table 8: Criteria and certification required for the UK ESR scheme.....	83
Table 9: Conversion of energy consumption indices into energy efficiency grades for the Hong Kong EELS	83
Table 10: Apparent EU25 consumption in units, 2005.....	85
Table 11: Apparent EU25 consumption in millions Euros, 2005.....	86
Table 12: Tumble dryers sales 2002 to 2007.....	88
Table 13: Tumble dryers sales in EU 27 + Turkey, broken down by heating air systems, in units..	90
Table 14: Sales by technologies, in units.....	90
Table 15: Sales distribution by technologies	91
Table 16: Sales by loading types, in units.....	91
Table 17: Sales distribution by loading types.....	91
Table 18: Sales by loading capacity, in units	92
Table 19: Sales distribution by loading capacity	92
Table 20: Sales by Energy efficiency classes, in units	93
Table 21: Sales distribution by energy efficiency classes.....	94
Table 22: Sales of washing-drying machines in Europe, in units.....	95
Table 23: Eurostat data for households from 1998 up to 2006 (in thousand).....	96
Table 24: Households number input for the stock model (in millions)	97
Table 25: Ownership rates input for the stock model.....	98
Table 26: Stock results for the stock model (in millions units)	98
Table 27: Waste curve recalculation using 2001 VHK report	100
Table 28: Estimated sales calculated through the stock model for EU 15 (in million units).....	101
Table 29: Estimated sales calculated through the stock model for new incoming countries.....	101
Table 30: Prices of tumble dryers in West Europe, broken by technologies	103
Table 31: Prices by technologies, East Europe	104
Table 32: Electricity prices per 100 kWh, incl. taxes.....	106
Table 33: Gas prices , January 2006 per GJ, incl. all taxes, for standard consumer 83.7 GJ/yr...	107
Table 34: Average Repair and maintenance costs (in Euros) broken down by parts of drying machines	108
Table 35: Weighting based on the population and penetration rate of the 3 countries.....	122

Table 36: Sales distribution by air technologies for tumble dryers.....	130
Table 37: Sales by air technologies, in units.....	130
Table 38: Sales of washing-drying machines in Europe, in units.....	130
Table 39: Extra energy consumption due to some options of the laundry dryer.....	150
Table 40: Average characteristics of an air vented tumble dryer.....	199
Table 41: Average material composition of an air vented tumble dryer (1).....	200
Table 42: Average material composition of an air vented tumble dryer (2).....	200
Table 43: Average characteristics of a compact air vented tumble dryer.....	201
Table 44: Average material composition of a compact air vented tumble dryer.....	202
Table 45: Average characteristics of an air condenser tumble dryer.....	206
Table 46: Average material composition of an air condenser tumble dryer(1).....	207
Table 47: Average material composition of an air condenser tumble dryer(2).....	208
Table 48: Characteristics of a top loading air condenser tumble dryer.....	209
Table 49: Material composition of a top loading air condenser tumble dryer (1).....	209
Table 50: Material composition of a top loading air condenser tumble dryer (2).....	210
Table 51: Standard conditions: general conditions for measurement.....	220
Table 52: Average drying cycle durations measured under standard conditions (with a load of 6kg)	220
Table 53: Product usage pattern definition (Real life conditions).....	221
Table 54: Average drying cycle durations calculated for real life conditions (with a load of 3.4kg).....	222
Table 55: Average energy consumption of air vented tumble dryers under standard conditions..	223
Table 56: Average energy consumption of air vented tumble dryers under real life conditions	223
Table 57: Average energy consumption of condenser tumble dryers under standard conditions.	223
Table 58: Average energy consumption of condenser tumble dryers under real life conditions ...	224
Table 59: Breakdown per components & subparts of the energy consumption of several types of laundry dryers (E_{Actual} under standard conditions with a load of 6kg).....	224
Table 60: Influence of the load on the energy consumption.....	225
Table 61: Relative energy demand with respect to spin speed / remaining water after spin.....	226
Table 62: Maximum saturation and absolute humidity at different temperatures and relative humidity.....	226
Table 63: Weight ratios for the three types of end of life treatments.....	237
Table 64: Standard Base Case (STBC) characteristics for both types of tumble dryers.....	245
Table 65: Real life Base Case (RLBC) characteristics for both types of tumble dryers.....	247
Table 66: Deviation from the average for air vented dryers.....	249
Table 67: Deviation from the average for air condenser dryers.....	249
Table 68: EcoReport material input table for the Base Case air vented tumble dryer.....	250
Table 69: Overview of the Bill of Materials (BOM) for the Base Case air vented tumble dryer	250
Table 70: Material distribution for the Base Case air vented tumble dryer.....	250
Table 71: EcoReport inputs for the distribution phase.....	251
Table 72: EcoReport energy inputs for the Standard Base Case (Air vented).....	252

Table 73: EcoReport energy inputs for the Real Life Base Case (Air vented).....	252
Table 74: EcoReport material input table for the Base Case air condenser tumble dryer.....	253
Table 75: Overview of the Bill of Materials (BOM) for the Base Case air condenser tumble dryer.....	253
Table 76: Material distribution for the Base Case air condenser tumble dryer.....	254
Table 77: EcoReport inputs for the distribution phase.....	254
Table 78: EcoReport energy inputs for the Standard Base Case (Condenser).....	255
Table 79: EcoReport energy inputs for the Real Life Base Case (Condenser).....	255
Table 80: EcoReport environmental assessment results under real life conditions (RLBC Air vented).....	257
Table 81: EcoReport environmental assessment results under real life conditions (RLBC Compact Air vented).....	263
Table 82: EcoReport environmental assessment results under real life conditions (RLBC Air condenser).....	265
Table 83: EcoReport environmental assessment results under standard conditions (Top air condenser).....	270
Table 84: Sales of C Class tumble dryers, 6kg, by type of technology and type of loading, in Western and Eastern Europe (2005).....	275
Table 85: EU Stock (EU 15, 2005), of C class, 6 kg load capacity, tumble dryers.....	275
Table 86: EcoReport inputs for the calculation of the LCC of the Base Case air vented tumble dryer (2005).....	276
Table 87: EcoReport results for the LCC of the air vented tumble dryer Base Case under standard conditions (STBC Air vented).....	276
Table 88: EcoReport results for the LCC for the Base Case air vented tumble dryer under real life conditions (RLBC Air vented).....	277
Table 89: EcoReport results LCC for the compact air vented tumble dryer, D Class, Front, under standard conditions.....	278
Table 90: EcoReport inputs for the calculation of the LCC of the Base Case condenser tumble dryer (2005).....	279
Table 91: EcoReport results for the LCC of the Base Case condenser tumble dryer under standard conditions.....	279
Table 92: EcoReport results LCC for the condenser tumble dryer, C Class, 6 kg, under real life conditions.....	280
Table 93: EcoReport results for the LCC for a condenser tumble dryer, C Class, Top, 5 kg, under standard conditions.....	281
Table 94: EcoReport output for air vented tumble dryers sold in the EU 25 in 2005.....	282
Table 95: EcoReport output for the EU25 total stock of air vented tumble dryers in 2005.....	283
Table 96: Summary of the environmental impacts of the EU 25 total stock of air vented tumble dryers in 2005.....	283
Table 97: EcoReport output for models sold in 2005 (for the standard base case).....	284

Table 98: EcoReport output for the EU stock of condenser dryers (2005) (for the standard base case).....	285
Table 99: EcoReport output for the EU stock of condenser tumble dryers (2005)	285
Table 100: Overview of best available dryer technologies.....	296
Table 101: Overview of environmental, economical and practical advantages and drawbacks regarding BAT	297
Table 102: Minimum improvement needed to achieve a better label (in Wh/kg load).....	305
Table 103: Design options.....	306
Table 104: Possible combinations of design options	308
Table 105: Overview of environmental, economical and practical advantages and drawbacks regarding BNAT.....	314
Table 106: List of the individual improvement options	323
Table 107: Assumptions for payback time calculations	324
Table 108: Energy savings potentials for the options applicable to both base cases.....	325
Table 109: Improvement options for air vented dryer (Loading considered=6kg)	327
Table 110: Improvement options for air vented dryer (Loading considered = 3.4 kg)	328
Table 111: Eco-report BOM in terms of relative increase or decrease of materials with reference to the condenser dryer base case	329
Table 112: Eco-report results with reference to the air vented dryer base case.....	330
Table 113: Ranking of the 3 best performing improvement options of the base case air vented dryer for each impact indicator	334
Table 114: Improvement options for condenser dryers (Loading considered = 6kg)	337
Table 115: Improvement options for condenser dryers only (Loading considered = 3.4 kg).....	337
Table 116: Eco-report BOM in terms of relative increase or decrease of materials with reference to the condenser dryer base case	338
Table 117: Eco-report results with reference to the condenser dryer base case.....	339
Table 118: Global warming potential for different type of refrigerant.....	339
Table 119: Ranking of the 3 best performing improvement options of the base case air condenser dryer for each impact indicator	343
Table 120: Summary of the cost and benefit effects of implementing individual improvement options for the base case vented dryers	347
Table 121: Summary of the cost and benefit effects of implementing improvement options or air vented dryers –options combinations are ranked by total LCC	351
Table 122: Eco-report results -This table is presented in relative improvement with the air vented base case as reference	354
Table 123: Summary of the cost and benefit effects of implementing individual improvement options for the base case Condenser dryers	356
Table 124: Summary of the cost and benefit effects of implementing improvement options for condenser dryers (full load base case) –options combinations are ranked by total LCC	361

Table 125: Ecoreport results for the least performing option (option3+4) and for the best performing option (1+5+6) – This table is presented in relative improvement with the condenser base case as reference	364
Table 126: Improvement insulation option relative improvement compared to the real life AV base case	372
Table 127: Improvement insulation option relative improvement compared to the real life CD base case	372
Table 128: Combined drying option relative improvement compared to the real life AV base case	373
Table 129: Combined drying option relative improvement compared to the real life CD base case	373
Table 130: Improved sensor control (load control) option relative improvement compared to the real life AV base case	374
Table 131: Improved sensor control (load control) option relative improvement compared to the CD base case	374
Table 132: Improved sensor control (intelligent load control) option relative improvement compared to the real life AV base case	375
Table 133: Improved sensor control (intelligent load control) option relative improvement compared to the real life CD base case	375
Table 134: Option 1 (Heat pump) option relative improvement compared to the AV base case ...	376
Table 135: Option 2 (Gas dryer) option relative improvement compared to the AV base case	376
Table 136: Option 3 (Exhaust heat recovery) option relative improvement compared to the AV base case	377
Table 137: Option 4 (Optimised process and system design) option relative improvement compared to the AV base case	377
Table 138: Option 5 (Improved motor concept) option relative improvement compared to the AV base case	378
Table 139: Option 6 (Heat recovery motor) option relative improvement compared to the AV base case	378
Table 140: Option 8 (Mix airflow system) option relative improvement compared to the AV base case	379
Table 141: Option 1 (Heat pump) option relative improvement compared to the CD base case ..	379
Table 142: Option 2 (Optimised process & System design) option relative improvement compared to the CD base case	380
Table 143: Option 4 (Heat recovery motor) option relative improvement compared to the CD base case	380
Table 144: Option 3 (Improved motor concept) option relative improvement compared to the CD base case	381
Table 145: Sales distribution by energy efficiency classes in 2005	390

Table 146: Hypotheses on stocks and sales repartition between air vented and condenser dryers	395
Table 147: Sales hypotheses for BaU scenario	396
Table 148: Sales hypotheses for the Conservative Scenario	396
Table 149: Sales hypotheses for the BAT-Moderate Scenario	397
Table 150: Estimation of range of subsidies for the BAT-Moderate Scenario	397
Table 151: Sales hypotheses for the BAT-Ambitious Scenario	398
Table 152: Estimation of range of subsidies for the BAT- Ambitious Scenario	398
Table 153: Sensitivity analysis on energy prices	403
Table 154: Sensitivity analysis on energy costs: payback time and LCC	403
Table 155: Sensitivity analysis on additional costs	404
Table 156: Sensitivity analysis on additional costs: payback time and LCC	404
Table 157: Cost effectiveness tipping point	405
Table 158: Scenario analysis: Electricity consumption (TWh)	419
Table 159: Scenario analysis: Primary energy consumption (GER, PJ).....	419
Table 160: Scenario analysis: GWP (mt CO ₂ eq.)	419
Table 161: Scenario analysis: Energy costs to consumers (million euros).....	419
Table 162: Sensitivity analysis (40 % penetration rate): Electricity consumption (TWh)	420
Table 163: Sensitivity analysis (40 % penetration rate): Primary energy consumption (GER, PJ)	420
Table 164: Sensitivity analysis (40 % penetration rate): GWP (mt CO ₂ eq.)	420
Table 165: Sensitivity analysis (40 % penetration rate): Energy costs to consumers (million euros)	420

i Introduction

i.1 Context of this project

The European Directive on Eco-design of Energy-using Products

Product related environmental impacts depend in a substantial manner on product design.

Many aspects of Energy-using Products (EuP) have negative impacts on the environment related to the energy they consume as well as other environmental impacts such as, for example, emissions to air, to water or to soil. Yet, it is considered that all product-related environmental impacts depend in a substantial manner on the design phase of a product.

European framework directive provides guidance on eco-design of Energy-using Products.

In 2005, the European Council and the European Parliament thus adopted a Commission proposal for a framework Directive on eco-design of EuPs. The directive provides further guidance in line with the European Integrated Product Policy (IPP) by incorporating legal requirement on product design which is one of the basics of the IPP for a given category of products.

Eco-design directive aims at improving products' performance while ensuring correct functioning of markets.

Within this context, the key objectives of the Directive 2005/32/EC are as follows:

- improve the environmental performance of the EuPs in the residential, industrial and tertiary sectors, throughout their entire life cycles by incorporating environmental aspects at the very beginning in the product design stage,
- facilitate the free movement of goods across the European Union and the enhancement of the intra-EU trade competitiveness,
- protect vested interests of each stakeholder notably the industry and the consumers,
- increase security of energy supply,
- establish a framework defining criteria and conditions for requirements concerning environmentally pertinent products features.

Eco-design requirements are being adopted by the EC assisted by a regulatory Committee after consultation with stakeholders. Preparatory work has been initiated for 20 product categories or families, including laundry dryers.

Implementing measures of the Directive have been adopted by the European Commission (EC) assisted by a regulatory Committee for defining eco-design requirements and conformity assessment procedures. Consultations on implementing measures creating eco-design commitments for selected EuPs have started in late 2007 and are expected to be adopted in 2008/2009.

These procedures are proposed for products or families of products which correspond to a significant volume of sales and trade in the intra-EU market (200 000 units/year) and which involve a noteworthy environmental impact. Currently, preparatory procedures have been started for 20 product families, including laundry dryers (lot 16).

The preparatory study seeks to define minimum eco-design criteria for laundry dryers.

The purpose of the study is to gather and compile existing data from various sources rather than 'reinventing the wheel'

The project uses MEEUP, a methodological approach covering eight tasks.

The purpose of the preparatory study for laundry dryers

A preparatory study provides the first stage of the policy process assessing the existing environmental impacts of specific product groups, identifying and suggesting means to enhance, when acting at its design phase, the environmental performance of a category of EuPs and supplying the necessary outcomes.

The purpose of this project on laundry dryers, Lot 16 of the second batch of preparatory studies launched by the European Commission in 2007, is to engage with stakeholders to gather and compile information with the objective of defining the most appropriate eco-design requirements for **laundry dryers**.

As such, the purpose of the reports presented here is not to 'reinvent the wheel'. They rather seek to gather and compile relevant information and therefore rely strongly on existing studies, external sources and inputs from stakeholders.

The scope of the preparatory study for Laundry dryers

In accordance with the terms of reference for this project, the consortium follows the Methodology Study Eco-Design of Energy-using Products (MEEuP³) developed for the European Commission.

The MEEuP approach covers the following tasks:

- **Task 1:** Definition
- **Task 2:** Economic and market data
- **Task 3:** Consumer behaviour and local infrastructure
- **Task 4:** Technical analysis of existing products
- **Task 5:** Definition of base case
- **Task 6:** Technical analysis of best-available-technology (BAT)
- **Task 7:** Improvement potential
- **Task 8:** Scenario-, policy-, impact- and sensitivity analysis

³ VHK (2005a).

This document gathers all previously published documents

i.2 Organisation of the document

This document gathers all final documents that have been published so far in the context of this preparatory study on laundry dryers (Lot 16):

- The final reports for Task 1 to Task 7, including their associated appendices which contain:
 - the references of all documents compiled for each task;
 - the summary of comments received from stakeholders for each task;
 - appendices specific to each task.

The minutes of the stakeholder meetings which summarize the discussions and decisions taken during these meetings are also annexed to this document. Please note that all presentations which launched the discussions during the three stakeholders meetings are available online at www.ecordyers.org

i.3 Planning of the project

This project was conducted following the ecodesign of EuP methodology (VHK 2005). The planning for the whole project is presented on the following page.

	2007												2008												2009	
	Months	December	January	February	March	April	May	June	July	August	September	October	November	December	January	February										
TASK 1 - DEFINITION																										
1.1 - Product category and performance assessment																										
1.2 - Test Standards																										
1.3 - Existing legislation																										
TASK 2 - ECONOMIC AND MARKET ANALYSIS																										
2.1 - Generic economic data																										
2.2 - Market and stock data																										
2.3 - Market trends																										
2.4 - Consumer expenditure base data																										
TASK 3 - CONSUMER BEHAVIOUR AND LOCAL INFRASTRUCTURE																										
3.1 - Real Life Efficiency																										
3.2 -End-of-Life behaviour																										
3.3 - Local Infra-structure																										
TASK 4 - TECHNICAL ANALYSIS EXISTING PRODUCTS																										
4.1 - Production phase																										
4.2 - Distribution phase																										
4.3 - Use phase (product)																										
4.4 - Use phase (system)																										
4.5 - End-of-life phase																										
TASK 5 - DEFINITION OF BASE-CASE																										
5.1 - Product-specific inputs																										
5.2 - Base-Case Environmental Impact Assessment																										
5.3 - Base-Case Life Cycle Costs																										
5.4 - EU Totals																										
5.5 - EU-25 Total System Impact																										
TASK 6 - TECHNICAL ANALYSIS BAT																										
6.1 - State-of-the-art in applied research for the product (prototype level)																										
6.2 - State-of-the-art at component level (prototype, test and field trial level)																										
6.3 - State-of-the-art of best existing product technology outside the EU																										
TASK 7 - IMPROVEMENT POTENTIAL																										
7.1 - Options																										
7.2 - Impacts																										
7.3 - Costs																										
7.4 - Analysis LLCC and BAT																										
7.5 - Long-term targets (BNAT) and systems analysis																										
TASK 8 - SCENARIO-, POLICY-, IMPACT- AND SENSITIVITY ANALYSIS																										
8.1 - Policy- and scenario analysis																										
8.2 - Impact analysis industry and consumers																										
8.3 - Sensitivity analysis of the main parameters																										
PROJECT MANAGEMENT																										
9.1 Meeting		X	Kick-off meeting						X	Progress meeting					X	Final meeting										
9.2 Follow up (phone, e-mails, Web meetings...)					X			X			X															
9.3 Web design, implementation and updating																										
9.4 Coordination and management	X	X	X	X	X	X	X	X	X	X	X	X	X	X	X	X										
Project Deliverables (+ review & approval)								X	Interim report					X	Final draft report											

Figure 1: Planning of the project

Continuous dialogue with stakeholders

Constant involvement of stakeholders has been possible through the project website: www.ecodryers.org. Moreover, three public stakeholder meetings took place in the offices of the European Commission in Brussels, respectively on 3 March 2008, 6 June 2008 and 12 December 2008. The minutes of these meetings, which summarize the discussions and the decisions taken, are annexed to this document.

Stakeholders were invited to provide comments and feedback that are addressed in a transparent manner.

The Consortium actively encouraged stakeholders to provide comments or modifications on any working document during the project, allowing for improvement of the accuracy and quality of the document. We therefore seek to take into account comments in an appropriate and transparent manner.

I Task 1: Definition

I.1 Product definition, standards and legislation (Task 1)

The objective of this section is to present and discuss the definition and scope of the product family 'laundry dryers' and to summarize applicable standard and test protocols, product legislation and voluntary initiatives in place.

I.1.1 Product definition

Laundry dryers: general definition(s)

Laundry dryers are defined by the service they provide: remove moisture of a given load of clothing or other textiles.

Laundry dryers are generally defined by the service they provide: remove the moisture of a (given) load of clothing or other textiles.

It is noteworthy that laundry dryers theoretically include clotheslines, drying racks and other devices used for "traditional" indoor or outdoor drying.

Product definitions for industry and commercial purposes

Product categories used in industry serve commercial purposes and mostly refer to technology-options.

Product categories in industry are usually defined for various commercial purposes such as marketing, market surveillance and statistics, standardization and labelling and therefore distinguish specific aspects of a product accordingly.

For example, the current practice in industry sectors consists of defining product categories according to the available technology-options rather than specific functions that the product provides: e.g. product categories tend to reflect the way products operate, or how they are maintained. In addition, the applicable legislation defines categories according to alternative criteria such as expected behaviour from the user or risk levels, as these issues matter when products are evaluated before being placed on the market.

Eco-design approaches start by defining the 'function' that a product provides (or 'functional unit'); ultimately seeking to provide the same (or improved service) while decreasing the environmental impact.

However, eco-design approaches commonly start by considering the 'actual service' that the product provides: the integration of environmental concerns into the design of new products or services therefore aims at providing the same service (or even an improved one) with a significant reduction of environmental impacts (see ISO 14062). All impacts (consumption and emissions) are aggregated first, and then compared to a measurement of the service provided (ISO 14040).

In addition, innovation is at the core of eco-design: available options for innovation will drive technology-change, and modify the way products are used. Sometimes, only 'thinking outside-the-box', thus implying fundamental changes (incl. changes in the technology-options) can achieve a significant decrease of undesired environmental impacts.

Seeking to define a 'functional unit' (as used by Life-Cycle Analysis practitioners) to define the scope of the project.

Thus, we suggest that the performance of the products should be the reference criteria for the definition of product category: performance criteria are indeed more adapted to the setting up of improvement targets and the definition of eco-design options. Within the common terminology of Life Cycle Assessment (LCA) practitioners, the service provided by a product is called the "functional unit", and a measurement of this functional unit is the "reference flow".

In order to agree on a common understanding about the products, their functionalities and the service(s) they provide, the first step consists of review of existing definitions and classifications. The definition of product categories will be based on the following sources, according to call for tender specifications:

Several product classifications prevail.

- EU trade classifications: the Prodcod list categories, from Eurostat and the classification of the Commission Taxation and Customs Union;
- Categories according to EN – or ISO – standard(s);
- Labelling categories (e.g. EU Energy Label or Eco-label), if not defined by the above.

Classification according to EU trade classifications

The classification used by the EC Taxation and Customs Union

The harmonised system (HS) classification identifies centrifuge-type dryers, laundry-type washing machines and other machineries.

The Harmonized Commodity Description and Coding Systems - generally referred to as "Harmonized System (HS)", is commonly used for several databases managed by the European Commission Taxation and Customs Union such as the EBTI (for Binding Tariffs), EXPORT (for tracking exported goods), etc. Among the 5,000 commodity groups identified by the six digit code, the headings referring to dryers are listed in the following table.

Table 1: Extract from HS Classification

8421	Centrifuges, including centrifugal dryers; filtering or purifying machinery and apparatus, for liquids or gases
8421.12	Clothes dryers
8450	Household or laundry-type washing machines, including machines which both wash and dry
8450.11	Machines, each of a dry linen capacity not exceeding 10 kg
8450.11	Fully-automatic machines
8450.11.11	Each of a dry linen capacity not exceeding 6 kg
8450.11.11	Front-loading machines
8450.11.19	Top-loading machines
8450.11.90	Each of a dry linen capacity exceeding 6 kg but not exceeding 10 kg
8450.12	Other machines, with built-in centrifugal drier
8450.19	Other
8450.20	Machines, each of a dry linen capacity exceeding 10 kg
8450.90	Parts
8451	Machinery (other than machines of heading 8450) for washing, cleaning, wringing, drying, ironing, pressing (including fusing presses), bleaching, dyeing, dressing, finishing, coating or impregnating textile yarns, fabrics or made-up textile articles and machines for applying the paste to the base fabric or other support used in the manufacture of floor coverings such as linoleum; machines for reeling, unreeling, folding, cutting or pinking textile fabrics
8451.21	Each of a dry linen capacity not exceeding 10 kg
8451.21.10	Each of a dry linen capacity not exceeding 6 kg
8451.21.90	Each of a dry linen capacity exceeding 6 kg but not exceeding 10 kg

Source: European Commission Taxation and Customs Union

According to industry experts, a specific subcategory for dryers not exceeding 6kg is no longer relevant in EU market.

Following initial discussion with industry stakeholders, it appears that this classification does not accurately reflect the product categories that are currently available on the market. Indeed, the reference to a classification "not exceeding 6kg" which stands out here was found to be obsolete as most household dryers now have capacities either inferior to 7-8 kg or comprised between 7-8 and 9-10kg, which was not yet the case some years ago.

PRODCOM refers to 'dryers' under several headings: machinery for textile, apparel and leather production, machinery for special purposes and electric domestic appliances.

The European PRODCOM classification

The PRODCOM list 2007, which classifies around 4,500 products manufactured in the EU-27 according to an eight-digit code, refer to 'dryers' under several headings (see Table below).

Table 2: Extract from PRODCOM List 2007

29.54	Manufacture of machinery for textile, apparel and leather production
29.54.22	Laundry-type washing machines; dry-cleaning machines; drying machines, with a capacity > 10 kg
29.54.22.30	Household or laundry-type washing machines of a dry linen capacity > 10 kg (including machines that both wash and dry)
29.54.22.70	Drying machines, of a dry linen capacity > 10 kg
29.54.42	Parts of machinery for other production of textiles and apparel and for the working of leather
29.54.42.10	Parts for household or laundry-type washing machines (including for those that both wash and dry)
29.56	Manufacture of other special purpose machinery n.e.c.
29.56.21	Centrifugal clothes-dryers
29.56.21.00	Centrifugal clothes-dryers
29.56.22	Dryers for wood, paper pulp, paper or paperboard; non-domestic dryers n.e.c.
29.56.22.50	Non-domestic dryers (excluding those for agricultural products, those for wood, paper pulp, paper or paperboard)
29.71	Manufacture of electric domestic appliances
29.71.13	Cloth washing and drying machines, of the household type
29.71.13.30	Fully-automatic washing machines of a dry linen capacity ≤ 10 kg (including machines which both wash and dry)
29.71.13.50	Non-automatic washing machines of a dry linen capacity ≤ 10 kg (including machines which both wash and dry)
29.71.13.70	Drying machines of a dry linen capacity ≤ 10 kg

Source: Eurostat

The categories mentioned above explicitly distinguish between domestic (8450 or 29.71) and other products (8451 or 29.54 and 29.56). It is also noteworthy that washing and drying machines (8450 or 29.54.22.30, 29.71.13.30 and 29.71.13.50) are clearly delineated from drying machines (8421 or 29.54.22.70 and 29.71.13.70). Machines which both wash and dry are grouped with washing machines.

Additional subcategories further differentiate dryers according to the method of drying (e.g. centrifugal), the material to be dried (e.g. clothes, wood), the dry linen capacity (superior or inferior to 10kg), control features (automatic or not) and design features (e.g. top/front loading).

The Prodcom classification was found to be more aligned with the actual market situation than the EC Trade and Customs Union classification. However, it does not permit to differentiate between all relevant products. Therefore, standards should be considered as reference for the classification.

Classification according to standards

Standards clearly differentiate between domestic dryers and other dryers. Broadly, relevant standards refer either to "household and similar electrical appliances" or to "industrial laundry machinery". When appropriate, most standards further define the specific product(s) to which they apply within these classes. The following types of laundry dryers have been identified:

Classifications according to additional subcategories also exist.

International standards differentiate domestic dryers (i.e. household appliances) from other dryers.

Industrial laundry machines can be distinguished according to the function they offer.

Industrial laundry machinery

Standards ISO and EN ISO 10472:1997 – ‘*Safety requirements for industrial laundry machinery*’ apply to laundry machinery designed for use in industrial laundry premises, which includes hotels, hospitals, nursing homes, prisons and similar premises, as well as machines designed for use in self-service establishments subject to certain minimum capacities.

Among industrial laundry machines, several products can be distinguished according to the function they offer.

Industrial tumble dryers

Industrial or batch drying tumblers (as referred to in ISO 9398-2:2003) are made to extract humidity by tumbling a humid laundry load in a rotating drum through an atmosphere heated by the dryer (see EN ISO 10472-4:1997).

Washer extractors

Washer extractors are machines which combine the functions of textile washing and moisture extraction by centrifugal action (see EN ISO 10472-2:1997).

Finishing tunnels

Finishing tunnels are machines made to dry and finish laundry in which humid clothes are suspended on hangers and loaded on an aerial transfer device which moves through the machine, starting with a high humidity atmosphere and followed by a dry and hot atmosphere produced by the finishing tunnel (see EN ISO 10472-4:1997).

Drying cabinets

For industrial/commercial purposes, drying cabinets are heated cabinets where laundry is suspended on hangers to be dried without being transported during the drying cycle (see EN ISO 10472-4:1997).

Flatwork ironing machines

Flatwork ironing machines are made primarily to iron laundry but they are equipped with heating cylinders which contribute to drying the laundry while it is being ironed (see EN ISO 10472-5:1997).

Household and similar electrical appliances

Washer dryers

A washer-dryer is defined as a type of washing machine in the ‘scope’ section of EN 60456:2005 – ‘*Clothes washing machines for household use - Methods for measuring the performance*’ (IEC 60456:2003, modified). Specifically, it is ‘*a washing machine which includes both a water-extraction (spin) function and also a means for drying the textiles, usually by heating and tumbling*’.

Tumble dryers

The definition of the product group can be found in the relevant measurement standard EN 61121:2005 ‘*Tumble dryers for household use - Methods for measuring the performance*’ (IEC 61121:2003, modified). The section related to definition and symbols defines a tumble dryer as an ‘*appliance in which textile material is dried by tumbling in a rotating drum, through which heated air is passed*’.

Tumble dryers can be either automatic or non-automatic and two main technologies exist for electric tumble dryers: air-vented tumble dryers and condenser dryers.

The standard specifies two types of dryers according to their control feature:

- **Automatic tumble dryer:** 'tumble dryer which switches off the drying process when a certain moisture content of the load is reached';
- **Non-automatic tumble dryer:** 'tumble dryer which does not switch off the drying process when a certain moisture content of the load is reached, usually controlled by a timer, but may also be manually controlled'.

Types are also defined based on what becomes of the air used for drying:

- **Air vented tumble dryer:** 'tumble dryer with a fresh-air intake which is heated and passed over the textile material and where the resulting moist air is exhausted into the room or vented outside';
- **Condenser tumble dryer:** 'tumble dryer in which the air used for the drying process is dehumidified by cooling'.

An explanatory note to this standard adds that combinations of air-vented and condensation tumble dryers types are possible.

The following Figure s illustrate the air vented and condenser tumble dryers. Arrows identify air flows.

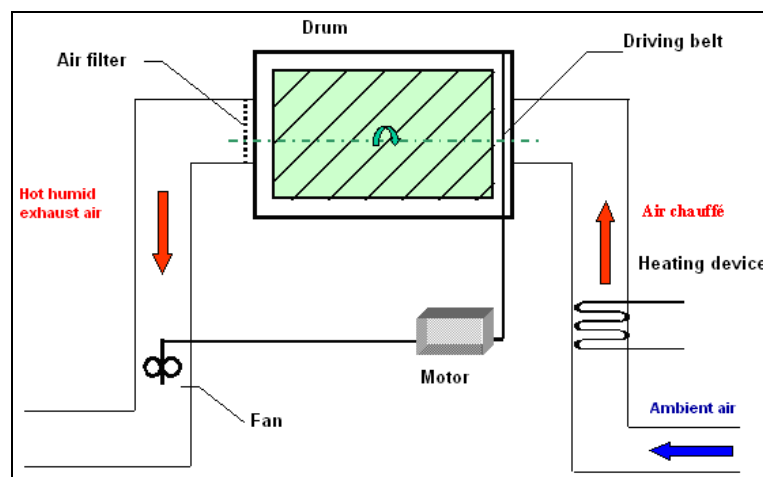

Figure 2: Electric air vented tumble dryer

Source: Adapted from Essaoui (2001)

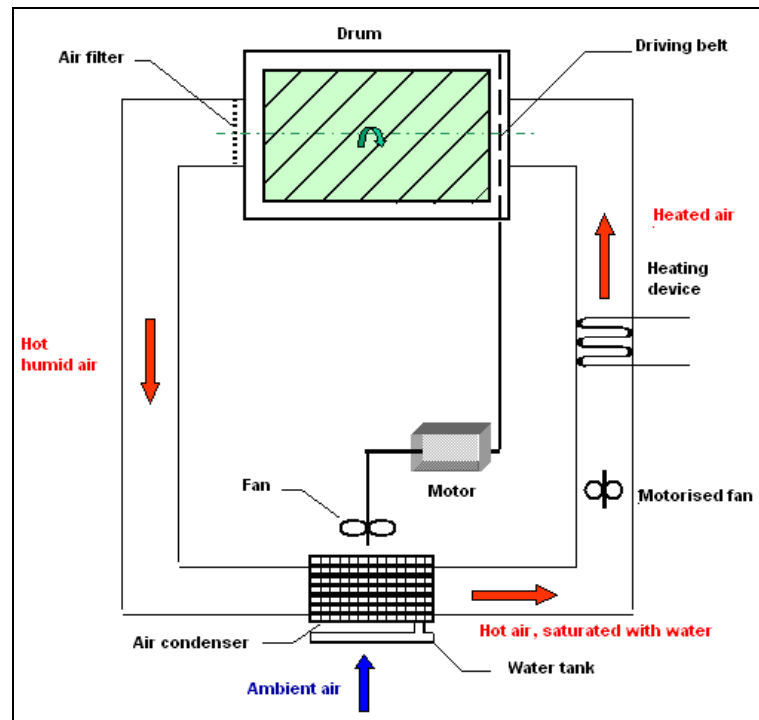

Figure 3. Electric condenser tumble dryer (air condenser dryer)

Source: Adapted from Essaoui (2001)

Three major technologies are defined by their respective cooling/condensing process: air condenser, water condenser and heat pump condenser.

In addition and in anticipation of the results of **Task 4 (technical analysis of existing product)**, we identified three main technologies for condensation dryers, depending on the cooling process of the air used for drying:

- **Air condenser dryer:** The ambient room air is used as a heat sink. It is blown across the outside of the heat exchanger to cool and dehumidify the warm air used for the drying process. This is the most common type of condenser dryers on the market.
- **Water condenser dryer:** Water is used to cool the warm air and condense the moisture. So far, it seems that there is no tumble dryer on the market using this technology. It is however usually what washer dryers rely on for their “drying” function.
- **Heat pump condenser dryer:** The heating and condensing is performed by the hot and cold plates of a heat pump. There are only a few models of tumble dryers available on the market which are based on this technology.

Finally, as previously mentioned, the EN 61121: 2005 standard applies to tumble dryers, implying that a rotational method comes into play. It is worth mentioning here that there are dryers which use a static method. Among these, the most important category is the household **drying cabinet**, where air is lead through the cabinet and passed through a dehumidifier to remove the moisture. Both dehumidifying technologies (vented/condenser) are present on the market. They are referred to in Part 2-43 of safety standard EN 60335.

The below summarises the various types of products for electric tumble dryers.

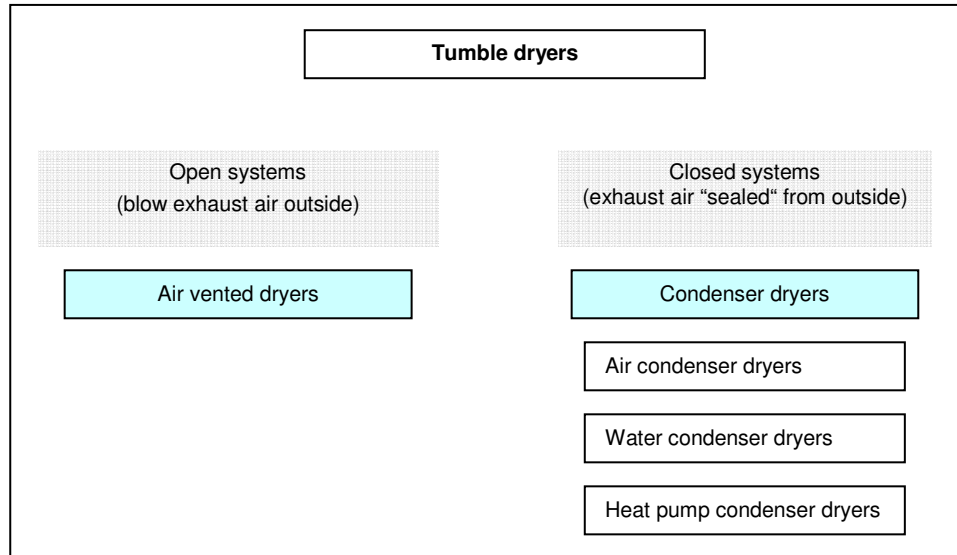

Figure 4: Overview of product types of existing electric tumble dryers

Household and similar gas appliances

Tumble dryers

Standard EN 61121: 2005 only applies to 'electric' tumble dryers; implied by opposition to gas-fired dryers. Indeed, depending on the energy source used to raise the temperature of the air flowing through the tumble (since the actual tumbling action is usually electrically powered), a tumbler dryer can be:

- **Electric tumble dryer:** the dryer generally uses a coiled wire heated with electric current. The amount of electric current is varied to adjust the temperature.
- **Gas tumble dryer:** a gas burner is used. The air temperature can be altered by adjusting the size of the gas flame or, more commonly, by merely extinguishing and relighting it. Note that the only technology option for gas tumble dryers is one similar to that of air vented electric tumble dryers.

Part 1 of standard EN 1458 'Domestic gas fired tumble dryers of types B_{22D} and B_{23D} , of nominal heat input not exceeding 6 kW' defines:

- **Direct gas fired tumble dryer** as an 'appliance in which textile material is dried by tumbling in a rotating drum through which heated air and products of combustion are forced or induced by mechanical means'

Note that gas appliances are classified into categories defined according to the gases and pressures for which they are designed and classified into several types according to the mode of evacuation of the combustion products/ supply of combustion air. For example,

- **Category I_{2H}:** Appliances using only gases of group H of the second family at the prescribed supply pressures.
- **Type B_{22D}:** 'A type B_{22} appliance (i.e. without a draught diverter but incorporating a fan downstream of the combustion chamber/ heat exchanger) that is intended to be connected to a flexible non-metallic duct that evacuates humid air and products of combustion to the outside of the room containing the appliance'.

- **Type B_{23D}**: *'A type B₂₃ appliance (i.e. without a draught diverter but incorporating a fan upstream of the combustion chamber/ heat exchanger) that is intended to be connected to a flexible non-metallic duct that evacuates humid air and products of combustion to the outside of the room containing the appliance'.*

For illustrative purposes, the below summarises the various products that have been identified as referred to under the denomination 'laundry dryers'.

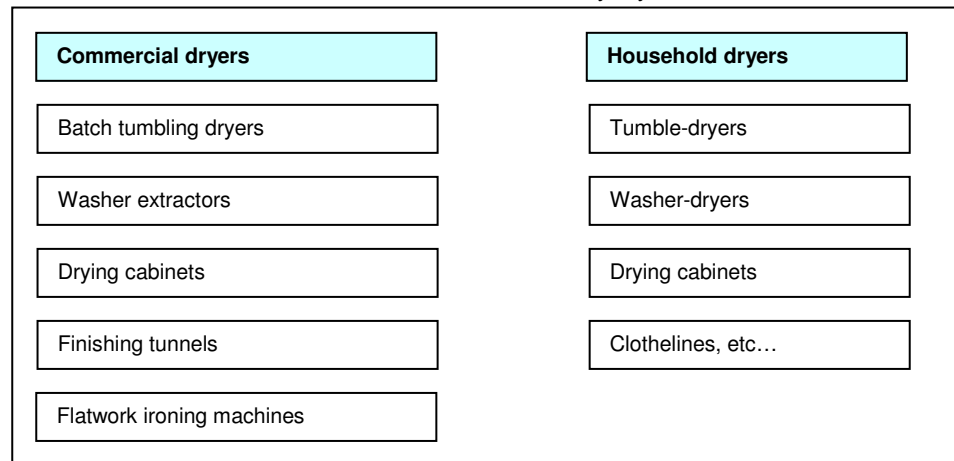

Figure 5: Overview of types of laundry dryers identified

Functional and performance parameters

For the user, the primary functionality of a laundry dryer is to dry laundry. To be more precise, it is to reduce the moisture content of a certain laundry load evenly, while respecting the quality of the fabric over its lifetime. The **functional unit** can thus be defined as drying a certain weight of laundry, to reach a certain degree of moisture, specified according to the subsequent end application of the fabric (e.g. laundry to be ironed, etc). Our work during the next tasks (especially tasks 3, 4 and 5) will enable us to define more precisely the functional unit for laundry dryers.

Functional unit can be defined as the weight of laundry dried per cycle to achieve a certain degree of moisture, specified according to the subsequent end application of the fabric.

1.1.2 Existing standards

ISO/IEC Guide 2:2004 defines a standard as 'a document, established by consensus and approved by a recognized body, that provides, for common and repeated use, rules, guidelines or characteristics for activities or their results, aimed at the achievement of the optimum degree of order in a given context'.

There are different types of standards that are of relevance for white goods such as performance standards, safety standards, etc.

In this document, we refer to international standards, European standards and national standards, which are described in the following sections.

International standards are voluntary but many have been adopted in national regulatory frameworks or serve as technical basis for national legislation.

International standards

The international standards mentioned in the document are:

- ISO (International Organization for Standardization) standards
- IEC (International Electrotechnical Commission) standards

International standards are voluntary but many have been adopted in some countries as part of their regulatory framework, or are referred to in legislation for which they serve as the technical basis.

European standards

European standards must be implemented at national level by being given the status of a national standard and withdrawing conflicting national standards.

European (EN) standards are documents that have been ratified by one of the three European Standards Organizations, CEN (the European Committee for Standardization), CENELEC (the European Committee for Electrotechnical Standardization) or ETSI (European Telecommunications Standards Institute). Many result from the adaptation of international standards, to ensure that they are appropriate to European conditions, etc.

The Internal Regulations, Part 2, state that the EN 'carries with it the obligation, to be implemented at national level, by being given the status of a national standard and by withdrawal of any conflicting national standards'.

National standards

Each country has its own standardization organisations and produces national standards.

Each country has its own standardization organisations and produces national standards which may or may not be aligned with international standards.

The most relevant international, European and other national standards which apply to drying appliances are only listed in this section. A more detailed analysis is performed in **Annex C**.

International and European standards

Test and Performance standards

Household appliances

Reference/Date	Title	Main points
EN 61121: 2005/ IEC 61121 ed. 3.1: 2005 (A1: 2005)	Tumble dryers for household use – Methods for measuring the performance.	<ul style="list-style-type: none"> ▪ Defines test methods for measuring performance of tumble dryers as regards the: drying performance, evenness of drying, condensation efficiency (for condenser dryers), water and electric energy consumption, programme time. ▪ The EN standard represents the basis of the current European energy labelling system for tumble dryers.
EN 60456: 2005 (A11: 2006)/ IEC 60456 ed. 4.0: 2003	Clothes washing machines for household use – Methods for measuring the performance.	<ul style="list-style-type: none"> ▪ Defines methods for measuring performance of clothes washing machines as regards the: washing, rinsing and spin extraction performance; shrinkage during the wool wash programme; water and energy consumption; programme time. ▪ The IEC standard is applicable to the wash part of washer-dryers.

Reference/Date	Title	Main points
EN 50229: 2007	Electric clothes washer-dryers for household use – Methods of measuring the performance.	<ul style="list-style-type: none"> ▪ Refers to methods defined in EN 61121 and EN 60456 for measuring performance of washer-dryers as regards the: washing, rinsing and spin extraction performance , water and electric energy consumption (for washing cycle, drying cycle and total), programme time (incl. separate measurement of drying time). ▪ Methods for noise emission values are those defined in EN 60704. ▪ The EN standard represents the basis of the current European energy labelling system for washer dryers.
EN 62301: 2005/ IEC 62301 ed. 1.0: 2005	Household electrical appliances – Measurement of standby power.	<ul style="list-style-type: none"> ▪ Defines methods for measuring the electrical power consumption in standby mode. ▪ Applicable to mains powered electrical household appliances and to the mains powered parts of appliances that use other fuels such as gas or oil.
EN / IEC 60704 EN 60704-1/ IEC 60704-1 ed 1.0 1997 EN 60704-2-6: 2004 EN 60704-3/ IEC 60704-3 ed.2.0 2006 IEC 60704-2-6 ed.2.0 (2005)	Household and similar electrical appliances – Test code for the determination of airborne acoustical noise.	<ul style="list-style-type: none"> ▪ Defines methods of determination of airborne acoustical noise emitted by household and similar electrical appliances. ▪ Part 1 states general requirements, ▪ Part 2-6 specifies particular requirements for tumble dryers, ▪ Part 3 defines the procedure for determining and verifying declared noise emission values.
EN 1458-2: 1999	Domestic gas fired tumble dryers of types B22D and B23D, of nominal heat input not exceeding 6 kW	<ul style="list-style-type: none"> ▪ Part 2 of this standard specifies the requirements and test methods for a rational use of energy.

Industrial laundry machines

Reference/Date	Title	Main points
ISO 9398: 2003	Specifications for industrial laundry machines – Definitions and testing of capacity and consumption characteristics.	<ul style="list-style-type: none"> ▪ Defines test methods for determining capacity and consumption characteristics with regard to machine capacity, power consumption and hourly productivity. ▪ Part 1 addresses flatwork ironing machines, ▪ Part 2 addresses batch drying tumblers, ▪ Part 3 addresses washing tunnels, ▪ Part 4 addresses washer-extractors.
EN 12752-2: 1999	Gas-fired type B tumble dryers of nominal heat input not exceeding 20 kW	<ul style="list-style-type: none"> ▪ Part 2 of this standard specifies the requirements and test methods for rational use of energy.

Safety standards

Reference /Date	Title	Main points
EN 12752-1: 1999	Gas-fired type B tumble dryers of nominal heat input not exceeding 20 kW	<ul style="list-style-type: none"> ▪ Part 1 specifies safety requirements for gas-fired type B tumble dryers of nominal heat input not exceeding 20 kW ▪ Part 2 specifies the requirements and test methods for rational energy use.

Household appliances

Reference /Date	Title	Main points
EN / IEC 60335 EN 60335-1: 2002 (A1: 2006) EN 60335-2-11: 2003 (A1: 2004, A2: 2006) EN 60 3335-2-43: 2003 EN 60335-2-102: 2006 IEC 60335-1 ed.4.2: 2006 IEC 60335-2-11 ed.6.0 (A1: 2005, A2: 2006): 2003 IEC 60335-2-43 ed.3.1: 2005 IEC 60335-2-102 ed.1.0: 2004	Household and similar electrical appliances – Safety	<ul style="list-style-type: none"> ▪ Deals with the safety of gas, oil and solid-fuel burning appliances having electrical connections, for household and similar purposes within specified voltage limits. ▪ Part 1 states general requirements, ▪ Part 2-11 specifies requirements for tumble dryers intended for household and similar purposes. ▪ Part 2-43 deals with the safety of electric clothes dryers for drying textiles on racks located in a warm airflow and to electric towel rails, for household and similar purposes, their rated voltage not exceeding 250V. The clothes racks may be fixed or free standing in a cabinet. The air circulation may be natural or forced. ▪ Part 2-102 specifies requirements for gas, oil and solid-fuel burning appliances having electrical connections.
EN 1458-1: 1999	Domestic gas fired tumble dryers of types B22D and B23D, of nominal heat input not exceeding 6 kW	<ul style="list-style-type: none"> ▪ Part 1 of this standard specifies safety requirements for domestic gas fired tumble dryers of types B22D and B23D, of nominal heat input not exceeding 6 kW

Industrial laundry machinery

Reference /Date	Title	Main points
EN / ISO 10472: 1997	Safety requirements for industrial laundry machinery.	<ul style="list-style-type: none"> ▪ Deals with safety requirements as regards: mechanical, electrical and thermal risks; risks linked to noise; to materials and products treated, used or degraded by the machines; to non respect of ergonomic principles at the conception phase; to failure of energy supply and other functional dysfunctions; risks occurring during maintenance/production. ▪ Part 1 states common requirements, Part 2 addresses washing machines, Part 3 addresses washing elements including washing components, Part 4 addresses air dryers and Part 5 addresses flatwork ironers, feeders and folders.

Electro Magnetic Compatibility (EMC) standards

Household appliances

Reference /Date	Title	Main points
EN / IEC 61000		<ul style="list-style-type: none"> ▪ Deals with different aspects regarding electro-magnetic compatibility ▪ Part 1 states general considerations, ▪ Part 2 describes and classifies the environment and specifies compatibility levels, ▪ Part 3 specifies emission and immunity limits, ▪ Part 4 defines testing and measurement techniques, ▪ Part 5 defines installation and mitigation guidelines, ▪ Part 6 defines generic standards, ▪ EN 61000 is the basis for the EMC European legislation.
EN 50366: 2003	Household and similar electrical appliances – Electro-magnetic fields – Methods for evaluation and measurement	<ul style="list-style-type: none"> ▪ Seeks to limit the electro-magnetic fields (EMF) produced by electrical household appliances in order to protect human beings, animals and plants.

Standards on environmental issues

Reference / Date	Title	Main points
IEC PAS 62545: 2007	Environmental information for electrical and electronic equipment (EIEEE).	<ul style="list-style-type: none"> ▪ Standardizes the process, methodology and indicators to be included in an environmental product declaration for Electrical and Electronic (E&E) products.
IEC 62430 (currently under development)	Environmentally conscious design (ECD) for electrical and electronic products and systems.	<ul style="list-style-type: none"> ▪ Will specify generic procedures to integrate environmental aspects into design and development processes of electrical and electronic products and systems

National standards*Test and Performance standards*

Household appliances

Reference / Date	Title	Main points
Australia / New Zealand		
AS/NZS 2442 AS/NZS 2442 – 1 (A1: 1998, A2:1999, A3: 2003, A4: 2006) AS/NZS 2442 – 2 (A1: 2006, A2: 2007): 2000	Performance of household electrical appliances – Rotary clothes dryers.	<ul style="list-style-type: none"> ▪ Part 1 of the standard defines the test procedures for the determination of energy consumption and performance of clothes dryers in Australia. ▪ Part 2 of the standard sets out the requirements for energy labelling of clothes dryers in Australia. An approved Energy Label for clothes dryers must be displayed on all products which are offered for sale in Australia.

Reference / Date	Title	Main points
AS/NZS 62301:2005	Household electrical appliances - Measurement of standby power	<ul style="list-style-type: none"> Based on IEC 62301, Ed. 1.0 (2005 MOD)
USA		
46 FR 27324	US Federal Register, final rule of 19 May 1981	<ul style="list-style-type: none"> Defines test procedures for residential clothes dryers. (Not updated since 1981 but currently under review). Establishes test procedure with provisions for measuring the energy factor (EF) Provides for a measure of standby mode energy consumption only for gas dryers, in the form of pilot energy consumption.
HLD-1: 1992	AHAM Performance Evaluation Procedure for Household Tumble Type Clothes Dryers	<ul style="list-style-type: none"> Basis for performance measurement of clothes dryers in the US, as stated in the electronic code of Federal regulations (10 CFR 430 Subpart B, App. D, 1, 1.7 and 1.1.8) – updated using the latest standard Drafted by the Association of Home Appliances Manufacturers (AHAM) .
Canada		
CAN/CSA-C361-92 (R2003)	Test Method for Measuring energy Consumption and drum volume of electrically heated household tumble-type clothes dryers	<ul style="list-style-type: none"> Specifies the methods for measuring the energy consumption (with associated energy factors) and drum volume, and for testing the performance characteristics, of automatic household electric tumble-type clothes dryers. Specifies maximum energy consumption limits. Applies to electrically operated and electrically heated household tumble-type clothes dryers, compact and standard, designed for a 60 Hz ac supply with a nominal system voltage of 120, 120/240, 120/208 V.
ANSI Z21.15-1997/CGA P.5-M97: 1997 (R2004)	Testing method for measuring per-cycle energy consumption and energy factor of domestic gas clothes dryers.	<ul style="list-style-type: none"> Defines test methods for measuring energy consumption and procedures for calculating energy factor. Applicable to compact size and standard size gas-fired clothes dryers for use in domestic applications.
Japan		
JIS C9812: 1999	Tumble dryers for household use – Methods for measuring the performance	<ul style="list-style-type: none"> Similar to IEC 61121:1997 but with changed load definitions.
JIS C 9608: 1993 (A1:2007)	Tumbler type electric clothes dryers.	<ul style="list-style-type: none"> Applies to tumbler type electric clothes dryers equipped with motor and electric heating device, intended for household use, having a standard drying capacity not exceeding 5 kg and a rated power consumption not exceeding 5 kW. First established in 1986 and drafted by the Japan Electrical Manufacturers' Association

Reference / Date	Title	Main points
JIS S 2130:1996	Gas burning clothes dryers for domestic use	<ul style="list-style-type: none"> ▪ Specifies the gas burning clothes dryers mainly for general domestic use taking as fuel the liquefied petroleum gas or city gas to be used by placing on a floor or board, whose indicated gas consumption is 5.81 kw: 20.9 mj/h (0.42 kg/h) or under for liquefied petroleum gas and 5.81 kw: 20.9 mj/h (5000 kcal/h) or under for city gas and with a standard drying capacity is 5 kg or under. ▪ First established in 1982 and drafted by the Japan Industrial Association of Gas and Kerosene Appliances
China		
GB/T 20292: 2006	Tumble dryers for household use - Methods for measuring the performance	<ul style="list-style-type: none"> ▪ Identical to IEC 61121 ed. 3.1

Industrial laundry machinery

Reference / Date	Title	Main points
France		
NF G 45 106 1997	Laundry equipment – Drying and ironing machine, rotating dryers, spinner washers with atmospheric burners of output not exceeding 120 kW using gaseous fuels.	<ul style="list-style-type: none"> ▪ Provides product definitions, an equipment classification and specifications for construction characteristics, operating and performance testing of gas laundry equipment.

Safety standards

Household appliances

Reference / Date	Title	Main points
Canada		
ANSI Z21.5.1- 2006/CSA 7.1-2006	Gas Clothes Dryers - Volume I, Type I Clothes Dryers	<ul style="list-style-type: none"> ▪ Specifies basic requirements for safe operation, substantial and durable construction, and acceptable performance of gas type 1 clothes dryers
ANSI Z21.5.2- 2005/CSA 7.2-2005 (a: 2006)	Gas Clothes Dryers - Volume II, Type II Clothes Dryers	<ul style="list-style-type: none"> ▪ Same as above, but for gas type 2 clothes dryers
Canada/USA		
CAN/CSA-C22.2 NO. 112-97 (R2007)/ UL 2158	Standard for Safety Electric Clothes Dryers	<ul style="list-style-type: none"> ▪ Safety requirements for electric clothes dryers intended to be used in nonhazardous locations in accordance with the Canadian Electrical Code, Part I (CEC), and the (U.S.) National Electrical Code (NEC), on circuits having a nominal voltage not exceeding 600 V. ▪ Applies to appliances intended for use by the general public not specifically trained in the use of the

Reference / Date	Title	Main points
		<p>appliance, regardless of the mode by which its operation is initiated, in households and for commercial purposes, including appliances provided with coin-, ticket-, or card-operated mechanisms, and combination washer-dryers.</p> <ul style="list-style-type: none"> Does not apply to industrial and institutional type appliances.
Japan		
JIS C 9335	Household and similar electrical appliances – Safety	<ul style="list-style-type: none"> Similar to IEC 60335 with minor modifications.
China		
C4125	Safety of household and similar electrical appliances	<ul style="list-style-type: none"> Similar to a previous edition of IEC 60335 with minor modifications. Part 2-11 addresses particular requirements for tumbler dryers.
The United Kingdom		
BS 7624: 2004	Specification for the installation and maintenance of direct gas-fired tumble dryers of up to 6 kW net heat input	<ul style="list-style-type: none"> Specifies the installation, including design, inspection and commissioning, of direct gas-fired tumble dryers of up to 6 kW net heat input burning 2nd and 3rd family gases for use in permanent domestic dwellings. Applies to any such tumble dryer used in conjunction with a flexible venting hose fitted to a wall or window vent terminal or, where the net heat input does not exceed 3kW, with a venting hose hung out of a window, so that combustion products and moisture are exhausted directly to the outside air.

Industrial laundry machinery

Reference / Date	Title	Main points
Canada/USA		
UL 1240	Electric Commercial Clothes-Drying Equipment	<ul style="list-style-type: none"> Safety requirements covering electric commercial, industrial, and institutional clothes-drying equipment intended for use in accordance with the National Electrical Code, NFPA 70. Equipment covered is not intended for use by the general public, but only by trained or supervised personnel. Does not cover coin-operated clothes-drying equipment, flatirons, ironing machines, water heaters, water softeners, dry-cleaning machines, garment-finishing machines, clothes washers, or other equipment covered by requirements of other standards. Appliances and field-attached accessories including those using some other source of energy - e.g. gas or steam- in addition to electric energy are investigated.

Conclusion on standards

As seen in section 1, standards give the most relevant product definitions of all sources identified, which could be used for specific measures following Annex II of the 2005/32/EC Directive. They also provide a good basis for products classification.

Following from the analysis of the standards listed above (see [Annex C](#)), several points are worth highlighting for this study. First, standards applying to commercial/ industrial dryers are clearly differentiated from ones applying to household type dryers. Moreover, there is no separate international standard for household type washer dryers whereas there is one at the European level for measuring performance. In any case, the washing and drying parts of washer dryers are treated separately, referring respectively to standards designed for washing machines and tumble dryers.

Tests standards for household type electric tumble dryers (automatic or not, air-vented or condenser type) around the world are mostly based on EN standards (themselves mostly based on IEC standards) except in North America, but testing conditions are usually slightly modified to suit local conditions. They are widely used by manufacturers, especially standard EN 61121 which specifies performance measurement methods and is the basis for the European mandatory energy labelling scheme. Most of the test methods identified are deemed suitably robust, reproducible and repeatable, except for the bone dry method described in the EN 61121 which raises concerns on the variability of the results (see [Annex C](#)). Now, the analysis carried out in following tasks should help ensure that they are sufficiently close to 'real life' use to provide relevant information.

Standards specifying test methods to measure the performance of gas fired tumble dryers are more problematic. Two European standards specifying requirements for energy consumption and test methods for measuring the energy performance have been identified. However, initial discussions with stakeholders from the industry indicate that the part concerning energy is not widely used: it is mostly the safety part that is used. There is currently no European standard which defines test and performance measurement methods allowing to compare gas and electric dryers.

I.1.3 Existing legislation and voluntary initiatives

The most relevant legislation and voluntary initiatives in place are listed here. A more detailed analysis of each is performed in **Annex D**

European legislation

Legislation related to energy

Reference	Common Name	Main points
Directive 92/75/EEC of 22 September 1992 on the indication by labelling and standard product information of the consumption of energy and other resources by household appliances (amending act: 1882/2003).	The Energy labelling Directive	<ul style="list-style-type: none"> ▪ Aims at harmonising national measures relating to the publication of information on the consumption of energy and of other essential resources by household appliances, thereby allowing consumers to choose appliances on the basis of their energy efficiency.
Directive 95/13/EC of 23 May 1995 implementing Council Directive 92/75/EEC with regard to energy labelling of household electric tumble driers.	Energy labelling of household electric tumble driers	<ul style="list-style-type: none"> ▪ Implements Directive 92/75/EEC with regard to electric mains operated household tumble driers. ▪ Specifies requirements for the label design and defines energy efficiency classes ▪ Refers to European harmonized test standard EN 61121 for measurement
Directive 96/60/EC of 19 September 1996 implementing Council Directive 92/75/EEC with regard to energy labelling of household combined washer-driers	Energy of household combined washer-driers	<ul style="list-style-type: none"> ▪ Implements Directive 92/75/EEC with regard to electric mains operated household combined washer-driers. ▪ Specifies requirements for the label design and defines energy efficiency and washing performance classes. ▪ Refers to European harmonized test standards EN 61121 and EN 60456 for measurement.

Legislation related to safety

Reference	Common Name	Main points
Directive 2001/95/EC of the European Parliament and of the Council of 3 December 2001 on general product safety.	The General Product Safety Directive (GPSD)	<ul style="list-style-type: none"> ▪ Purpose: to ensure that products placed on the market are safe. ▪ Annex II describes procedures for RAPEX (rapid alert system for products which pose a serious risk).
Directive 90/396/EEC Council Directive of 29 June 1990 on the approximation of the laws of the Member States relating to appliances burning gaseous fuels.	The Gas Appliance Directive (GAD)	<ul style="list-style-type: none"> ▪ Looks to ensure that gas appliances placed on the market are safe. ▪ Appliances specifically designed for use in industrial processes carried out on industrial premises are excluded.
Directive 97/23/EEC of the European Parliament and of the Council of 29 May 1997 on the approximation of the laws of the Member States concerning pressure equipment	The Pressure Equipment Directive (PED)	<ul style="list-style-type: none"> ▪ Seek for harmonisation of the national legislation of Member States concerning the design, manufacture, testing and conformity assessment of pressure equipment and assemblies of pressure equipment constituting an integrated whole.

Legislation related to Electro Magnetic Compatibility issues

Reference	Common Name	Main points
Directive 2004/18/EC of the European Parliament and of the Council of 15 December 2004 on the approximation of the Laws of Member States relating to electro-magnetic compatibility – repeals Directive 89/336/EC.	The Electro Magnetic Compatibility Directive (EMCD)	<ul style="list-style-type: none"> ▪ Aims at regulating the compatibility of equipment regarding EMC in order to guarantee the free movement of apparatus and to create an acceptable electro-magnetic environment in the Community territory.
Directive 2006/95/EC of the European Parliament and of the Council of 12 December 2006 on the harmonisation of the laws of Member States relating to electrical equipment designed for use within certain voltage limits (codified version) (the codification required a new number but the text is the same as 73/23/EEC).	The Low Voltage Directive (LVD)	<ul style="list-style-type: none"> ▪ Aims at ensuring that electrical equipment within certain voltage limits both provide a high level of protection for European citizens and enjoy a Single Market in the European Union.

Legislation related to environmental issues

Reference	Common Name	Main points
Directive 2002/96/EC of the European Parliament and of the Council of 27 January 2003 on waste electrical and electronic equipment .	The Waste Electrical and Electronic Equipment Directive (WEEE)	<ul style="list-style-type: none"> ▪ Aims at preventing WEEE arising; to encourage reuse, recycling and recovery of WEEE and to improve the environmental performance of all operators involved in the lifecycle of EEEs. ▪ Requires the separate collection of WEEE.
Directive 2002/95/EC of the European Parliament and of the Council of 27 January 2003 on the restriction of the use of certain hazardous substances in electrical and electronic equipment.	The Restriction of Hazardous Substances Directive (RoHS)	<ul style="list-style-type: none"> ▪ Seeks the protection of human health and the environment by restricting use of certain hazardous substances in new equipment and to complement WEEE Directive. ▪ Requires the substitution of various heavy metals and brominated flame retardants in new EEE put on the market.
Regulation (EC) No 842/2006 of the European Parliament and of the Council of 17 May 2006 on certain fluorinated greenhouse gases.	Reduction in fluorinated greenhouse gases	<ul style="list-style-type: none"> ▪ Aims at reducing emissions of certain fluorinated gases (HFCs, PFCs and sulphur hexafluorides), to improve their containment and monitoring and restrict their marketing and use.

Legislation outside the EU*Legislation related to energy*

Reference / Date	Main Points
Australia	
Star Rating Scheme (Electric)	<ul style="list-style-type: none"> ▪ Mandatory Energy labelling including clothes dryers since 1989/90. ▪ Controlled by State legislation (rather than national legislation) and now coordinated by the National Appliance Equipment Energy Efficiency Committee (NAEEEC)
Canada/Ontario	
Energy Efficiency Act, S.C. 1992, c.36 Regulation: Energy Efficiency Regulations, SOR/94-651, as amended EnerGuide Program	<ul style="list-style-type: none"> ▪ Set minimum energy performance standards (MEPS) for specified energy-using products (including standard and compact clothes dryers) and provide descriptions of the responsibilities of dealers in these products. ▪ The Act sets out labelling standards for energy-using products, collection of statistics and information on energy use and alternative energy.
USA	
The Energy Conservation Act (EPCA) of 1975	<ul style="list-style-type: none"> ▪ Establishes an energy conservation programme for major household appliances. ▪ Additional amendments to EPCA have given DOE the authority to regulate the energy efficiency of several products, including residential clothes dryers

Reference / Date	Main Points
The National Appliance Energy Conservation Act of 1987	<ul style="list-style-type: none"> Contains amendments to the EPCA which establish prescriptive energy conservation standards for residential clothes dryers as well as requirements for determining whether these standards should be amended.
The National Energy Conservation Policy Act of 1978 (NECPA)	<ul style="list-style-type: none"> Establishes a conservation programme for certain industrial equipment
US Federal Register, final rule of 14 May 1991, 56 FR 22250	<ul style="list-style-type: none"> First set of performance standards for residential clothes dryers which became effective on 14 May 1994.
New Zealand	
Energy Efficiency and Conservation Act of 15 May 2000	<ul style="list-style-type: none"> Gave the government power to make labelling mandatory and MEPS requirements for appliances
Energy Efficiency (Energy Using Products) Regulations 2002 - Star Rating Scheme	<ul style="list-style-type: none"> Specifies minimum energy performance, and requirements in relation to labelling, including some for clothes dryers.

Legislation related to environmental issues

Reference / Date	Title	Main Points
France		
Decree n° 2007-737 of 7 May 2007, regarding certain refrigerant fluids used in refrigeration and air conditioning equipments.	<ul style="list-style-type: none"> This decree regulates the conditions for placing on the market, use, recovery and destruction of substances listed in Annex I. It deals with all the equipments and installations including heat pumps. 	

Voluntary initiatives

In addition to specific legislations, some stakeholders from the private and public sectors have developed voluntary schemes to improve the environmental performance of products and the information provided to consumers. In the following paragraphs, the main voluntary initiatives applicable to laundry dryers are presented. It should be noted that they apply only to electric dryers, unless specified otherwise.

Country & Agency	Programme Name	Main Points
Australia		
Australian greenhouse office	Top energy saver award (TESAW)	<ul style="list-style-type: none"> Indicates that a product is the best in its class in terms of energy efficiency and cost savings. All appliances that carry a comparative energy label (gas & electric) are eligible.
Chinese Taipei (Taiwan)		
Energy commission	Energy conservation label	<ul style="list-style-type: none"> Energy label.
Environmental and development foundation (EDF)	Greenmark	<ul style="list-style-type: none"> Eco label.
UK		
Energy saving trust (EST)	Energy saving recommended (ESR) label	<ul style="list-style-type: none"> Energy label for gas & electric dryers.
Hong Kong		
Electrical and mechanical services department of the government of Hong Kong	Hong Kong voluntary energy efficiency labelling scheme (EELS)	<ul style="list-style-type: none"> Energy label.

Conclusion on legislation and voluntary initiatives

At the European level, there is no specific legislation for dryers apart from that regarding energy labelling (and this currently concerns only electric tumble dryers, excluding gas appliances). There is no EU-wide mandatory measure regarding the efficiency of dryers. Dryers are electrical or gas equipment and it is as such that they are subject to other European directives and regulations, mainly regarding safety, electro technical and environmental issues.

In other parts of the world, clothes dryers are clearly not a priority type of appliance for legislation or regulation. This is easily understandable in Southern developing countries where climatic conditions and living conditions leave little room for the use of laundry dryers. In industrialized countries, the situation is not homogeneous. Canada and the USA⁴ have the broadest ranging energy label and minimum energy performance standards (MEPS) applying to clothes dryers but in most countries there are no MEPS nor labels.

In relation to the different types of dryers identified: there is no labelling scheme (either mandatory or voluntary) for commercial dryers. There is no specific legislation applicable to dryers other than electric tumble dryers and washer-dryers, in particular gas fired tumble dryers and drying cabinets (the UK Market Transformation Programme recommends inclusion of a ventilation point in all newly built homes in the UK so as to enable the installation of airing cupboards fitted with MVHR⁵).

Concerning voluntary initiatives, there is only a little percentage of existing ones which consider clothes dryers in their scope. This seems to stem from the idea that clothes dryers are energy intensive appliances which use should be avoided altogether. This is what gives them a low priority on such schemes.

Furthermore, nearly all voluntary initiatives considering clothes dryers deal exclusively with energy labelling and fail to address other aspects of the environmental performance (the only exception is the Taiwanese Greenmark label). None of the most common “eco-labels” deals with clothes dryers. According to European industrial sources, the European Eco-label is unlikely to do so in the near future: it is assumed that consumers would not perceive (and therefore would not be willing to pay for) the value of environmentally superior performance in dryers. The US Department of Energy (DoE) justifies the absence of an Energy Star label for clothes dryers based on the results of a detailed study conducted by the DoE’s Appliance Standards Program which shows that most dryers on the US market have a similar energy consumption: even though they are energy intensive, the lack of differentiation fails to justify the needs for this comparative label. This is also the reason why the Federal Trade Commission (FTC) does not require clothes dryers to have a yellow Energy Guide label⁶. Over the next few years, the DoE Appliance Standards Program will be revisiting this study as it determines to see if changes in technology and market conditions make an ENERGY STAR clothes dryers program more feasible (see [Annex D](#)).

Finally, no industry voluntary commitment is in place for laundry dryers in Europe whereas there is one for washing machines for example. It is unlikely than any can be concluded as CECED indicated that they would not pursuer the one on washing machines and call for regulations.

⁴ However in the U.S.A, the regulation dealing with the performance of clothes dryers is obsolete due to their classification as “a low priority” and a rulemaking process is underway (see [Annex D](#))

⁵ MVHR : Mechanical Ventilation and Heat Recovery.

⁶ The yellow EnergyGuide label, familiar to most appliance shoppers in the U.S., helps consumers compare the operating costs of competing models and aids them in identifying high-efficiency models that will reduce their energy use.

Product categories, standards and main applicable legislations clearly show the specificities of household vs industrial/commercial laundry dryers

I.1.4 Preliminary scope of the project

We presented product categories, standards, main applicable legislations and voluntary initiatives for both household and industrial/commercial appliances. It appears that the most widely considered products are electric tumble dryers, either air vented or air condenser. The following tasks will thus consider them. The inclusion in the scope of other types of products, which may be considered under the definition of “laundry dryers”, is discussed in the following.

Industrial and commercial dryers

Products identified for commercial and/or industrial applications differ from those used by households in several ways. First there are products offering functions that are usually not offered by household products, finishing tunnels are one example. As for technical characteristics, they have larger heating capacities than domestic ones (implying different design constraints) and are commonly available with gas fired and steam heating systems whereas these options can hardly be found on the market for household appliances in Europe.

Moreover, as can be seen from the list in section 2.2, standards clearly state whether they apply to industrial/commercial machinery or household appliances. This implies that requirements differ greatly. It is however noteworthy that “household” standards apply to ‘*household and similar appliances*’, thus encompassing use in communal laundry rooms in blocks of flats.

Regarding legislation, no energy label applies to commercial or industrial dryers. This stems from the assumption that life cycle costing already plays an important role in the purchasing decision of commercial buyers (as opposed to households) and thus is also already dealt with at the manufacturers’ level. If the energy performance is already an essential sales argument, expected efficiency gains are therefore likely to be smaller than for household appliances, supposing that agents have a rational behaviour (this assumption may need to be proved right).

Now, available data on commercial and/or industrial dryers is very limited. Moreover, these appliances are used in such a broad range of settings that it makes it difficult to define a common base case for the entire category. Indeed, each situation faces its own constraints and specific requirements (e.g. there are requirements due to contamination risks in hospitals, etc.).

Commercial/industrial dryers were included in the preliminary scope of this study (i.e. Task 2). However, based on the results and based on discussions during the second stakeholder meeting, it was then decided to exclude them from the scope of the study (see Second stakeholders meeting minute in Annex).

Washer dryers

Definitions provided by standards and initial discussion with stakeholders indicate that washer-dryers should be considered as washing machines with a drying option, implying that technologies are very different from those used for tumble dryers (for example, design constraints include leaving enough room for a water container around the drum to contain the water used for washing, which limits the drum capacity and has a repercussion on the loads dried by users).

This point is also reflected in the standards and legislation applicable to washer dryers: when the piece is not designed specifically for washer dryers, reference is made to pieces concerning washing machine machines for the washing performance and to

tumble dryers for the drying performance. Concern have been raised that what differs from what is dried by a washer dryer (e.g. different initial moisture content, etc).

At present, washer dryers have a relatively small market share in Europe. Yet, changes in lifestyle (including smaller average household size, increasing share of women working and thus less time dedicated to household chores, etc) may point to an increasing share of these products on the European market.

Since washer dryers were not included in the scope of EuP preliminary study Lot 14 *Domestic washing machines and dishwashers*, they were included in the preliminary scope of this study (i.e. Task 2). Based on the results and based on discussions during the second stakeholder meeting, it was then decided to exclude them from the scope of the study (see Second stakeholders meeting minute in Annexe of this report).

Drying cabinets

According to initial research, drying cabinets represent only a very small number of units on the market and they are unlikely to gain a significant share in the near future. Furthermore, there is very limited available data. It was decided to exclude them from the scope of the study (see Second stakeholders meeting minute).

Gas-fired tumble dryers

According to a study by the ECI⁷, gas dryers currently have a small market share (0 to 0.3% for the three countries considered in the study: the UK, the Netherlands and Portugal). The same study also assumed that gas dryers were unlikely to gain significant market share, at least before 2020.

Yet, gas dryers have lower running costs and may allow significant savings of CO₂ emissions (since they use primary energy) compared to electric dryers. Initial discussions with industry experts indicate that gas dryers are not included in the scope of common tumble dryers standards and labelling schemes precisely because they use primary energy, and thus the energy performance depends on the energy mix of the country where the appliance is used, which renders comparison and labelling difficult, if not irrelevant. Therefore, additional work aiming at defining indicators and methods to measure performance is required to allow for comparison between gas and electric tumble dryers.

Now, environmental benefits and economic costs hinge upon energy-mix and availability of gas infrastructure, which differ among Member States: an EU-wide policy measure might not be the appropriate policy response. However, at Member State level for example, the UK government's Market Transformation Programme (MTP)⁸ goes so far as suggesting that provisions should be made to include a gas supply point in all newly built homes in order to allow easy installation of gas tumble dryers at reduced costs. It was decided to consider them as a BAT and study them as such (see Second stakeholders meeting minute).

⁷ Environmental Change Institute (2000).

⁸ Market Transformation Programme (2007a).

Annexes to Task 1

A References

- AG DEWHA Australian Government Department of the Environment, Water, Heritage and the Arts website:
<http://www.energyrating.gov.au/cdstar>
<http://www.energyrating.gov.au/tesaw-main.html>
- BOE, Energy label website, Bureau of Energy (BOE) of the Ministry of Economic Affairs; available at:
http://www.energylabel.org.tw/application_en/efficiency/upt.asp?cid=8
- CECED (2008a) *CECED submission to the Commission consultation document on the revision of the Energy Labelling Directive 92/75/EEC*, European Committee of Domestic Equipment Manufacturers, Brussels, 1 February 2008
- DECADE and Fawcett T, Lane K, Boardman B et al (2000) *Lower Carbon Futures for European Households*, Environmental Change Institute, Oxford, March 2000; available at:
<http://www.eci.ox.ac.uk/research/energy/downloads/lowercarbonfuturereport.pdf>
- e3 (2007) *Energy round table meeting – April 2007 – for whitegoods and air conditioners summary*, Equipment energy efficient (e3) available at:
<http://www.energyrating.gov.au/library/pubs/2007-roundtable-wgoods-ac.pdf>
- EMSD (2006) *The Hong Kong voluntary energy efficiency labelling scheme (EELS) for electric clothes dryers*, Electrical and mechanical services department (EMSD), Hong Kong, January 2006
- ENEA (2007) *Preparatory study for Eco design requirements of EuPs – Lot 14: Domestic dishwashers and washing machines*, draft final report prepared for the European Commission, DG-TREN, July 2007, available at:
<http://www.ecowet-domestic.org/>
- EPA ROC Green Mark website, Environmental Protection Administration (EPA) of the Republic of China (ROC); available at:
<http://greenmark.epa.gov.tw/english/workprm.asp>
- Essaoui (2001) *Présentation du sèche-linge*, Fagor-Brandt internal documentation.
- EST Energy Saving Trust website; available at:
http://www.energysavingtrust.org.uk/esr/esr/product_criteria_registration/home_appliances/electric_tumble_dryers_1
- Gensch C-O and Rüdener I (2004) *Energy demand of tumble driers with respect to differences in technology and ambient conditions*, Öko Institute, final report prepared for the European Committee of Domestic Equipment Manufacturers (CECED), Freiburg, 13 January 2004.
- Harrington L., Damnic A. (2004) *Energy labelling and standards programs throughout the world*, report commissioned and published by the National Appliance and Equipment Energy Efficiency Committee (NAEEEC), Australia, ed. 2.0, July 2004
- Harrington (2006) *Progress on Product Profiles*, November 2006, available at:
<http://www.energyrating.gov.au/pubs/2006-sb-ausnz-harrington.pdf>
- Klug H-J (2007) *Overview of clothes dryers and tumble dryers*, Power Point presentation for liaison between IEC SC59D and ISO TC38 SC2, Las Vegas, July 2007
- Market Transformation Programme (2007a) *Briefing Note IBNW24: Innovation Briefing Note on domestic laundry drying products*, Market Transformation Programme, Version 1.2, last reviewed 26 October 2007, available at:
<http://www.mtprog.co.uk/ApprovedBriefingNotes/pdf.aspx?intBriefingNoteID=487>

- Market Transformation Programme (2007b) *Briefing Note BNW09: Energy and performance test methodologies for domestic tumble driers*, Market Transformation Programme, Version: 2.2, last reviewed 25 October 2007; available at: <http://www.mtprog.com/ApprovedBriefingNotes/pdf.aspx?intBriefingNoteID=224>
- Market Transformation Programme (2007c) *Briefing Note BNW18: Energy and performance test methodologies for domestic tumble driers*, Market Transformation Programme, Version 1.2, last reviewed 18 January 2008; available at: www.mtprog.com/ApprovedBriefingNotes/pdf.aspx?intBriefingNoteID=345
- NAEEC (2003) *Product Profile – Clothes dryers*, National Appliance and Equipment Energy Efficiency Committee, initiative of the Ministerial Council of Energy, Australia's standby power strategy 2002-2012, available at: <http://www.energyrating.gov.au/library/pubs/sb200309-dryers.pdf>
- NRCAN Natural Resources Canada website:
<http://oee.nrcan.gc.ca/regulations/html/Factsheet5.cfm?text=N&printview=N>
<http://oee.nrcan.gc.ca/regulations/guide.cfm?PrintView=N&Text=N>
<http://oee.nrcan.gc.ca/regulations/product/integrated-clothes-washer-dryers.cfm?Text=N&PrintView=N>
- U.S. DoE (2007) *Energy conservation standards – Rulemaking framework document for residential clothes dryers and room air conditioners*, U.S Department of Energy (DoE) Office of energy efficiency and renewable energy building technologies program, 24 October 2007; available at: http://www.eere.energy.gov/buildings/appliance_standards/residential/clothes_dryers_framework.html
- VHK (1995a) *Driers: long term energy efficiency targets, a technical and economic analysis*, Van Holsteijn en Kemna, background report 8 (Task 3b) prepared for the Group for Efficient Appliances (GEA), 1995
- VHK (2005b) *Methodology Study Eco-Design of Energy-using Products (MEEUP)*, Van Holsteijn en Kemna, final report prepared for the European Commission, DG-TREN, Delft, 28 November 2005; available at: http://ec.europa.eu/enterprise/eco_design/relactiv.htm
- Wilkenfeld G. (2007) *Extending the Water Efficiency Labelling and Standards (WELS) scheme to washer/dryers and condenser dryers*; available at: <http://www.energyrating.gov.au/pubs/2007-whitegoods-cw-cd-wilkenfeld.pdf>

B Summary of comments from stakeholders

Submission	Comment	Response
06/03/08 Ana Patricia López Blanco CECED	List of EN EMC standards and Japanese & Chinese national standards.	Added to the list.
13/03/08 Jamie Hothersall Crosslee UK	<p>Page 12 states that “no international or European standard applies to gas dryers”. This is certainly the case for performance measurement (although the essential requirements of 61121:2005 can be applied to gas dryers in order to make comparisons with electric variants), but there is most definitely in existence EN1458 “Domestic direct gas-fired tumble dryers of types B22D and B23D, of nominal heat input not exceeding 6kW”. This safety standard appears to be missing from your list of International and European standards.</p> <p>Page 21 of the document refers to the criteria laid down by the Energy Saving Trust in the UK and notes that “in February 2007, a category for gas –fired domestic tumble dryers was established as part of the ESR scheme”. To clarify this further, the criteria used was that a gas dryer had to have carbon emissions or primary energy useage equivalent to or better than that of an electric tumble dryer in EU energy label band “B”. Further to this, in December 2007, the two separate categories (one for electric dryers and one for gas dryers) were merged into one category covering all tumble dryers.</p> <p>In response to the comments made on page 22, I would simply note that the cost of a gas dryer, plus the installation/connection costs, is still less than the cost of a heat pump electric dryer.</p> <p>The gas dryer is a classic example of eco-design. It achieves the fundamental need to reduce environmental impact whilst providing the consumer with the same service as an equivalent electric tumble dryer.</p> <p>40% of domestic tumble dryers in the United States are heated by gas. Less than 1% of domestic tumble dryers in the EU are heated by gas. This gas dryer product represents a tiny fraction of our manufacturing output but equally represents a major potential carbon reduction opportunity for the EU and beyond.</p> <p>Gas tumble dryers emit ~20% less carbon than heat pump electric dryers, and ~50% less carbon than a typical energy “C” condenser dryer.</p> <p>All EU member states have calculations for the carbon emissions per kWh of electricity for their given power generating mix, along with forecasts to 2020. Using the most optimistic of these generating mixes, the gas dryer still has the best carbon footprint of any tumble dryer.</p>	<p>Added to the list.</p> <p>Added to the relevant section in the report.</p> <p>Gas dryers might be studied as a BAT</p>

Submission	Comment	Response
	<p>You state that “if justified by a clear advantage in terms of their overall environmental performance, further standardization and research is needed before they (gas dryers) can be included in the scope of the eco-design implementing measures”. The overall environmental performance is clear, so perhaps you could clarify what further research is needed as we may be able to assist you in this regard.</p> <p>The pursuit of improved energy labelling does not encourage step change – it simply encourages modifications to existing concepts. Manufacturers cannot be blamed for using the energy label as a driver – but eco-design would be better served if the energy label was converted to a carbon label.</p>	<p>This specific point will be considered in Task 8.</p>
<p>17/03/08 Nicola King Intertek</p>	<p>The position of washer dryers within the EUP process is not clear. The Lot 14 preliminary study has excluded them from its policy proposals for washing machines and your project currently intends to exclude them from the Laundry Dryer study. An opportunity will be missed to bring this product into the scope of EUP implementing measures if it is not included in both these projects. This could also have an impact on the revision of the energy label for washer driers if the options for improvement are not identified as part of the EUP process.</p> <p>Your comment on page 25 regarding the drying capacity of washer dryers is only partly correct for the UK's situation. In 2007 56% of washer dryers sold in the UK were 6kg load wash capacities (from Gfk sales data). The wash load capacity is in some ways irrelevant because consumers rarely manage to fill their machines to this capacity. However, it does give the machine an advantage when the energy label is calculated if a larger capacity can be tested. As a result, many 6 kg wash capacity washer dryers, including the UK market leaders such as Hotpoint, offer a 5 kg wash and dry option, so that consumers are offered a similar experience to those that use a washer and separate dryer in terms of washing a load and then drying it all. In practice, this means the average consumer load (around 3.5 kg) as identified by the Lot 14 study could be easily washed and dried in one run by these machines.</p> <p>By excluding washer dryers from this study you will also lose the opportunity to asses whether the water used in the drying cycle of a washer dryer is environmentally significant and whether it could be reduced. In the UK we see models on the market that use as little as 4 litres per kg of load and as much as 16 litres per kg of load</p> <p>In terms of consumer use, it is difficult to know exactly whether owners of washer dryers use them differently to owners of washing machines and tumble dryers and if they use the washing function differently to owners of washing machines only. You could take the approach that we use when modelling use for the UK Defra Market Transformation Programme and assume it is the same on average.</p> <p>Historically, in the UK, in the mid-1980s, washer dryers were made that did not consume water in the drying cycle and had to be vented in the same way as vented dryers. It would be interesting to review what the environmental impacts of this technology would be.machines to this capacity.</p>	<p>Washer dryers are included in the preliminary scope of the study.</p>

Submission	Comment	Response
	<p>On the subject of gas driers it is not entirely clear if you intend to include or exclude them. Page 22 seems to suggest that they will be excluded. However, if they are included in the study you have the opportunity to review the estimated carbon emissions in the various electricity generation mixes in the EU and invite stakeholder comments. They can be tested using EN 61121 and gas consumption measured. Intertek has undertaken this work for some of our clients and would be happy to discuss this with you if required.</p> <p>With regard to sales of gas appliances in the EU, please contact Jamie Hothersall at Crosslee in the UK if he has not already contacted you</p> <p>It may be that gas dryers are not appropriate for all EU countries because of climate and infrastructure issues such as the availability of gas supplies and the carbon emissions, but this should be reviewed at this time in the scope of this project.</p> <p>There is also potential in this project to review the relative running costs to consumers in different EU countries compared to the electric equivalent.</p> <p>Gas dryers form a much higher percentage of sales in other markets, such as the USA, where they form around 20% of the market. They are recommended by the consumer organisation because of the lower running costs.</p> <p>Please note that water condensing tumble dryers could become a part of the EU market. Hoover has one in its product list, but to my knowledge this has never actually appeared in the UK</p> <p>The CLASP website gives a comprehensive list of all voluntary and mandatory labels and standards for laundry dryers. Your summary table on page 20 does not seem to include all of these, for example it mentions New Zealand but not Australia.</p>	<p>Gas dryers might be studied as a BAT.</p> <p>Noted. The website has been checked and relevant information added.</p>
<p>17/03/08 Annette Gydesen, Viegand & Maagøe, on behalf of the Danish Energy Agency</p>	<p>We recommend that the study also includes commercial tumble driers up to a certain size. The technology for commercial tumble driers is very similar to the technology of household dryers but the operation time will be much longer for commercial dryers. Longer operation time and more frequently use will probably extend the number of cost effective savings options for commercial dryers.</p> <p>As mentioned at the stakeholder meeting commercial tumble dryers for communal use in blocks of flats or in launderette as found in large number e.g. in Denmark are working in the same way and are drying the same type of clothes as the smaller household tumble dryers. These machines often have a capacity below 10kg.</p> <p>Also the standard EN 60456 for household washing machines covers washing machines for communal use in blocks of flats or in launderette as it says in the scope.</p> <p>The study should also investigate the energy consumption and energy efficiency improvement options for gas fired tumble dryers.</p> <p>We also recommend the study to deal with drying cabinets.</p>	<p>Commercial dryers are included in the preliminary scope of the study.</p> <p>Gas dryers might be studied as a BAT</p>

Submission	Comment	Response
	<p>It is mentioned that “no international or European standard.....applies to gas appliances...”You should be aware of: EN 1458-2:2001 Domestic direct gas-fired tumble dryers of types B22D and B23D, of nominal heat input not exceeding 6 kW - Part 2: Rational use of energy.</p> <p>Section 2.2 includes a lot of general information on standardisation, which could be leaved out.</p> <p>On section 2.3: The problem of comparing the energy consumption and CO2 emissions of electric and gas fired tumble dryers does not require further standardisation work. However the standards for gas fired tumble dryers needs to describe how to measure the gas consumption and the electricity consumption of the dryers under similar circumstances as for the electric tumble dryers.</p> <p>Aspects which should be addressed in standardisation work:</p> <ul style="list-style-type: none"> •The test methods for condenser dryers should deal with the amount of moisture exhausted to the room in which the tumble dryer is placed. •If gas tumble dryers are not included in the new version of the IEC 61121 it is important to investigate the need for a new standard on gas tumble dryers and if relevant that work on a new standard is started as soon as possible. <p>The statement mentioned in the bottom of page 38 and the top of page 39 represents the view of CECED. We agree on the goal (to have a more dynamic labelling scheme) but not necessarily in the procedure described (adding of new energy efficiency classes on the top etc.).</p>	<p>Noted and added to the list. However the last European version is 1999 and not 2001.</p> <p>Noted.</p> <p>Noted.</p> <p>Noted and added to the relevant part of the study.</p> <p>Ok. It is presented as such.</p>
<p>17/03/08 Edouard Toulouse ECOS</p>	<p>We were contacted a month ago to discuss the participation of environmental NGOs in the EuP preparatory study on laundry dryers. At that time we had no idea about our strategy concerning this product group.</p> <p>After a discussion involving the main European green NGOs (ECOS, EEB, WWF, Inforce, CAN), we have decided to have only a limited participation. This means we won't appoint a technical expert for in-depths activities. Although laundry dryers are intensive EuPs, we haven't identified them as a priority for us in this process. The main reason is that Environmental NGOs globally believe energy-consuming dryers should be avoided in the first place. The priority is to make sure alternatives to dryers (such as hanging clothes) are facilitated (for instance through building legislation and public campaigns). Therefore Environmental NGOs want to focus primarily on alternatives to dryers.</p> <p>Anyway this does not mean we are not interested by the study at all. I will still follow-up the process, so please leave my address in your mailing lists. In case you spot a particular topic where Environmental NGOs would absolutely be helpful, please don't hesitate to contact me.</p>	<p>Ok.</p>

C Relevant existing standards

The household dryer performance standards

International standard IEC 61121 and European standard EN 61121

The 3rd edition of IEC 61121 'Tumble dryers for household use – Methods for measuring the performance' was published in 2002, prepared by SC 59D – 'Home laundry appliances' of Technical Committee 59 – 'Performance of household and similar appliances'. Edition 3.1 (Edition 3: 2002 consolidated with amendment 1: 2005) was published in 2005.

Scope

The object of the international standard is to state and define the principal performance characteristics of household electric tumble dryers of interest to users and to describe standard methods for measuring them. More specifically, it applies to 'household electric tumble dryers of the automatic and non-automatic type, with or without a cold water supply and incorporating a heating device'.

Main performance parameters

The main performance parameters defined in this standard are:

- Final moisture content
- Condensation efficiency (for condenser dryers)
- Evenness of drying
- Programme time
- Electric energy consumption
- Water consumption

Test method

Broadly, the method for measuring these parameters consists of preparing a test load according to the rated capacity of the dryer and conditioning it, wetting and spinning the load to achieve a specific initial moisture content before putting it into the dryer. The initial weight is measured and the initial humidity of the load is calculated. The relevant programme is then set.

Throughout the drying process, measurements are recorded relating to the water characteristics (temperature, flow rate, pressure, hardness, conductivity), the energy consumed, the ambient temperature and humidity. The duration of the drying process is also recorded and the final weight is measured.

This allows to calculate the final moisture content and the evenness of drying. For condenser dryers, the mass of moisture condensed during the cycle and collected in the container is used to determine the condensation efficiency. For air vented dryers, under certain circumstances, energy losses occur and are estimated proportionally to the air volume of exhaust air. The measured electric and water consumption and the measured programme time are corrected to correspond to the nominal final moisture content and shall be averaged over the valid cycles (a minimum number of valid cycles is required for each parameter).

Two types of test loads are defined:

- **Cotton test load:** consists of conditioned sheets, pillowcases and hand towels. For each type of item, the criteria they have to fulfil (e.g. yarn, dimensions, etc...) are specified, the number of each (depending on the rated capacity of the dryer) and the conditioning method are also defined in the standard.
- **Easy care textile test load:** consists of an equal number of men's shirt and pillowcases satisfying certain specified criteria and adjusted closest to the rated capacity of the dryer.

The accuracy for each measure instrument and the conditions for measurements are defined. For resources and ambient conditions, the values and tolerance requirements relate to electricity supply (supply voltage and frequency); water supply (water hardness; temperature of cold water supply when applicable; pressure of water supply during water intake; conductivity); ambient temperature and ambient humidity.

The 3rd edition contains improvements over earlier editions of the standard and most of the tests defined in the standard are suitably robust, reproducible and repeatable. However, there are still areas for improvement.

Issues and limitations of the 3rd edition

Some of the issues and limitations of the 3rd edition are common to that of the IEC 60456 identified in Lot 14 (for household washing machines):

- Testing is currently limited to a single water hardness of 250ppm, which is too hard for many countries
- Cold water test temperature of 15 °C is unrealistically low (too cold) for some countries

There are also issues specific to this standard. In particular:

- According to the MTP, the 'bone-dry' method, used to determine the weights of test loads, does not produce consistent results: they vary according to the type and size of the dryer used. This can lead to variability in the results of other tests.
- The test methods for condenser dryers do not deal with the amount of moisture exhausted to the room in which the tumble dryer is placed.
- The scope of the standard currently excludes gas heated dryers and does not consider CO₂ emissions/efficiency, making it impossible to compare gas and electric dryers in terms of energy efficiency, carbon emissions and overall drying performance.
- The scope of the standard also excludes household dryers that are not tumble dryers, such as drying cabinets.

Work in progress

Maintenance Team 14 (MT14) is working on the global relevance and acceptance of IEC 61121 but this is a delicate issue which requires extensive research and development work.

In the shorter term, the Committee draft (CD) of the 4th edition of IEC is expected for mid 2008. The main issues considered are:

- bone-dry specification
- extension of scope: drying cabinet
- alignment with 5th edition of IEC 60456
- new target range of final humidity content

- influence of water quality on final humidity content
- description of uncertainty of measurement ; in general, elimination of other uncertainties
- improvement of final moisture and energy consumption measurement
- assessment of evenness of drying
- exhaust air measurement
- drum volume measurement

Discussion with experts suggests that gas dryers will not be included in the new version.

The maintenance result is expected for 2009.

As for the European standard, the text of the International Standard IEC 61121:2002, together with the common modifications prepared by the Technical Committee CENELEC TC 59X, Consumer information related to household electrical appliances, was submitted to the Unique Acceptance Procedure (UAP) but did not receive sufficient support. A new draft, including also the corrigenda April 2003 and September 2003 to IEC 61121:2002, allowing to maintain the classification of tumble dryers according to the energy label Directive 95/13/EC, was submitted to the formal vote and approved by CENELEC as EN 61121 in March 2005. Significant technical differences include the neutralization of the reference machine in 7.3.2 and the addition to Z1.1 which describes factors which shall be used to correct the value for the energy consumption.

The EN 61121 represents the basis of the current European labelling system and needs to be revised in parallel to the IEC 61121.

European standard EN 1458

Scope

This standard applies to domestic direct gas-fired tumble dryers, of types B_{22D} and B_{23D}, of nominal heat input not exceeding 6 kW.

This standard does not apply to catalytic combustion appliances; appliances designed exclusively for industrial purposes; appliances intended to be used in locations where special conditions prevail, such as the presence of a corrosive or explosive atmosphere; appliances of the condensing type wherein the heated air and products of combustion used for the drying process are dehumidified by cooling with water or air; appliances intended to be used in vehicles or on board ships or aircraft.

The first part of the standard specifies the requirements and test methods for the construction, safety, marking and testing of the appliances. The second part of the standard specifies the requirements for rational use of energy.

Main performance parameters

The main performance parameters defined in Part 2 of this standard are:

- Final moisture content
- Gas consumption

Test method

Broadly, the test method is the same as in EN 61121, except values for ambient conditions and load preparation differ slightly.

The consumption of gas is measured and expressed per kilogram of standard load in megajoules (based on the gross calorific value, in which the water produced by combustion is assumed to be condensed) and may be corrected as specified.

Requirement on energy consumption

The appliance shall have a gas consumption (based on gross calorific value) not exceeding 4,0 MJ/kg of standard load.

The main issue with this standard is that Part 2 seems not to be in use among gas tumble dryers' manufacturers and it does not provide results comparable with those of EN 61121 for electric tumble dryers.

The standard for household appliances airborne acoustical noise measurement

International IEC 60704 and European standard EN 60704

This section is adapted from ENEA (2007).

Scope

The International standard specifies methods of measurements for noise emissions. It applies to electric appliances for household use and similar use (i.e. use in similar conditions as in households, e.g. in hotels etc...). It excludes appliances, equipment or machines designed exclusively for industrial or professional purposes and appliances which are integrated parts of a building or its installations.

Moreover, this standard is concerned with airborne noise only, while in some cases, structure borne noise, e.g. transmitted by the adjoining room, may be of importance.

Test Method

Part 1 permits the use of 'semi-anechoic rooms', 'special reverberation test rooms' and 'hard-walled test rooms' for the measurement of the sound power level of the appliance based on acoustic measuring methods described in relevant other ISO standards⁹. For tumble dryers, specific requirements are defined in Part 2-6.

The determination of noise levels is generally part of a comprehensive testing procedure, covering many aspects of the properties and performance of the appliance. Ambient and operating conditions, accuracy of measure instruments and precision levels required are specified accordingly.

The resulting airborne acoustical noise is measured as sound power levels (L_w), in decibels (dB) with reference to a sound power of 1 picowatt (1 pW), within a specified frequency range of interest.

The European standard EN 60704 is adapted from IEC 60704.

⁹ ISO 3743 : 1994 *Acoustics – Determination of sound power levels of noise sources – Engineering methods for small movable sources in reverberant fields*. Part 1 : *Comparison methods for hard-walled test rooms* and Part 2 : *Methods for special reverberation test rooms*.
ISO 3744 :1994 *Acoustics – Determination of sound power levels of noise sources using sound pressure – Engineering method in an essentially free field over a reflecting plane*

The standard for household appliances standby power measurement

International IEC 62301 and European standard EN 62301

This section is adapted from ENEA (2007).

Scope

The International standard specifies methods of measurements of electrical power consumption in standby mode. It applies to all devices that are plugged into the electric mains by the end user. It provides general conditions for measurements (configuration of the tested equipment, environment, power supply, supply-voltage, waveform, power measurement accuracy, testing instrumentation, number of test and time of measurement) and for the test procedure.

The standby mode is defined as the lowest power consumption mode which cannot be switched off (influenced) by the user and that may persist for an indefinite time when an appliance is connected to the main electricity supply and used in accordance with the manufacturer's instructions. The standby mode is usually a non-operational mode when compared to the intended use of the appliance's primary function.

Test Method

If power consumption is stable (defined as less than 5% variation from the mean over an interval of 5 minutes), then the power consumption can be read directly from the meter; if power consumption fluctuates, then energy consumption should be measured over a period of time and then divided by the measurement period to determine average power.

Ambient and operating conditions for testing are defined. The accuracy of the measuring equipment is also defined but depends on the amount of power being measured.

The standby power is defined as the average power in standby mode, measured in Watts (W).

Note that the IEC 62301 is currently being studied by IEC TC 59 and will be subject to changes.

The European standard EN 62301:2005 is adapted from IEC 63201:2005.

The standards on environmental issues

International standard IEC PAS

This PAS (Public Available Specification) provides guidelines to disclose credible, relevant, and harmonized product related environmental information (called EIEEE) to who needs or requests it. As a result, generic requirements to be followed by upstream suppliers to deliver necessary information to downstream producers are also specified.

The EIEEE shall make it possible to exchange reliable information along the supply chain. This may be done in particular on demand of EEE producer to assess the conformity of their products to the relevant environmental regulations or to prepare homogenous answers to increasing and various requests for environmental information from stakeholders.

This PAS is stand-alone and only applicable if relevant requirements on environmental aspects and impacts information do not exist in relevant product standard.

The future International standard IEC 62430 on eco design

The standard will describe the methodology and the core elements of the integration of environmental aspects into the product planning and development process and is closely aligned with IEC Guide 114 and ISO TR 14062.

The standard will be a horizontal standard and allow sector or company specific solutions within its frame. It will be applicable to large, medium and small enterprises (SMEs).

The standard will incorporate ecodesign into the decision making design process. Specifications in the standard will be confined to factors that could be influenced by designers. Statements on other factors are only informative at the moment.

D Relevant existing legislation

The EU Energy labelling

Directive 92/75/EEC, Directive 95/13/EEC, Directive 96/60/EEC

The Energy Labelling Directive 92/75/EEC is one of a series of measures introduced by The European Commission under their programme of consumer and environmental protection: 'Specific Actions for Vigorous Energy Efficiency (SAVE).

It requires that appliances be labelled to show their power consumption in such a manner that it is possible to compare the efficiency with that of other makes and models. The intention is that consumers will prefer more energy efficient appliances over those with a higher consumption, resulting in less efficient products eventually being withdrawn or decommissioned.

Scope

It applies to the following types of **household appliances**, even where these are sold for non-household uses: refrigerators, freezers and their combinations, washing machines, dryers and their combinations, dishwashers, ovens, water heaters and hot-water storage appliances, lighting sources, air-conditioning appliances. Others may be added.

Note that since CE marking a product is not permitted unless it complies with all the directives which apply to it, it follows that CE marked appliances must also comply with the Energy Labelling Directive.

Labelling requirements and definition of classes

The Energy Labelling Directive is what is known as a 'framework directive', in that it does not of itself specify any limits or performance levels. It provides a legislative framework into which other directives can be introduced to require marking and performance levels for particular types of domestic appliance.

Relevant implementing directives are Directive 95/13/EEC and Directive 96/60/EEC which apply respectively to electric mains operated household

tumble dryers, explicitly excluding combined washer-dryers, and to combined washer-dryers. Appliances that can also use other energy sources are excluded. Both directives state requirements in terms of conception of the label and define energy efficiency classes. Directive 96/60/EEC also defines washing performance classes. Measures for determining the energy consumption and the washing performance should be carried out in accordance with European test standards: respectively EN 61121 and EN 50229 (note that they are mentioned at the bottom of the label). For noise emissions, the noise measurement standards are the relevant parts of EN 60704.

For the classification of tumble dryers, the energy consumption E measured under the new conditions requested by the standard EN 61121: October 2005 (*60% of initial moisture instead of 70%, 23 °C for ambient temperature instead of 20 °C, 55% for ambient humidity instead of 65%*) is corrected as follows:

- for a condenser dryer by multiplying E by 1,14:

$$E_{\text{corr}} = E \times 1,14$$

- for a vented dryer by the calculation of the equation:

$$E_{\text{corr}} = E \times 1,14 + 0,08 \text{ [kWh / h]} \times t[\text{h}]$$

Where t is the total program time expressed in hours.

N.B.: This correction is necessary to maintain the energy label class classification more or less unchanged due to the change in testing conditions compared to EN 61121:1999.

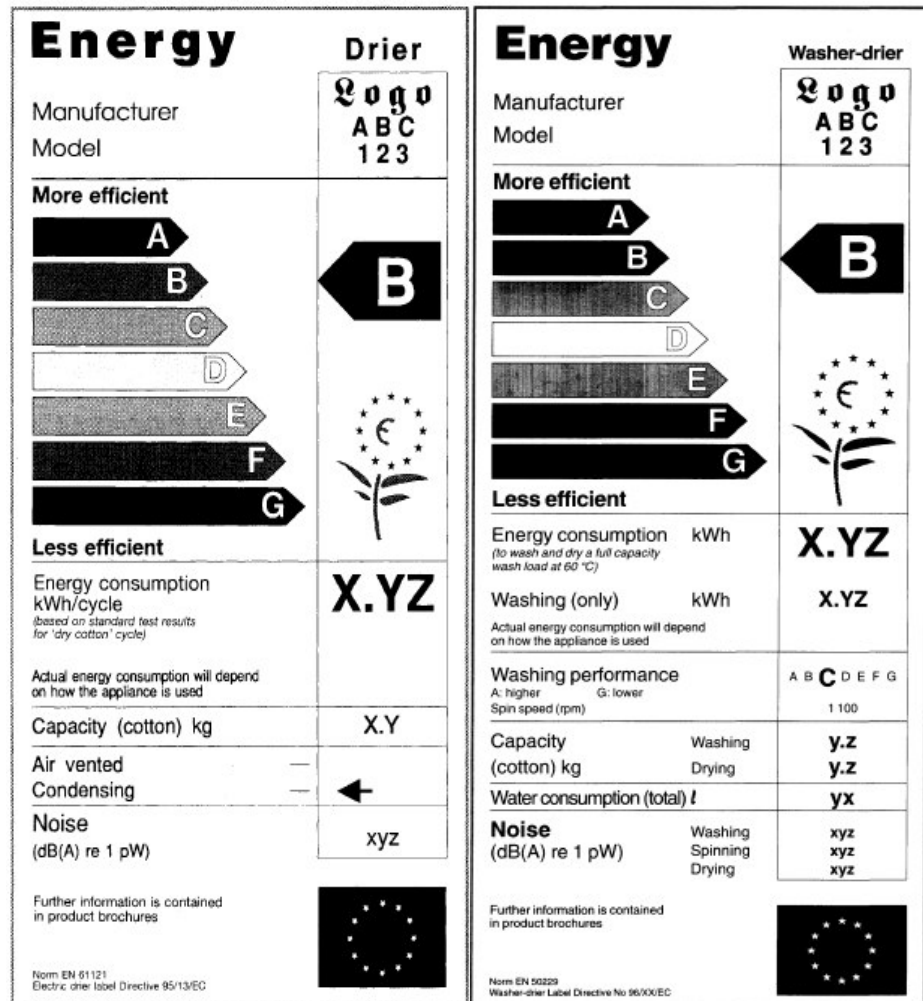

Figure 6: Energy label for electric tumble dryers (left) and washer dryers (right)

Table 3: Energy efficiency classes for air-vented tumble dryers

Energy efficiency class	Energy consumption 'C' in kWh per kg of load using test procedures of the harmonized standards referred to in Article 1 (2) with 'dry cotton cycle'
A	$C \leq 0,51$
B	$0,51 < C \leq 0,59$
C	$0,59 < C \leq 0,67$
D	$0,67 < C \leq 0,75$
E	$0,75 < C \leq 0,83$
F	$0,83 < C \leq 0,91$
G	$C > 0,91$

Table 4: Energy efficiency classes for condenser tumble dryers

Energy efficiency class	Energy consumption 'C' in kWh per kg of load using test procedures of the harmonized standards referred to in Article 1 (2) with 'dry cotton cycle'
A	$C \leq 0,55$
B	$0,55 < C \leq 0,64$
C	$0,64 < C \leq 0,73$
D	$0,73 < C \leq 0,82$
E	$0,82 < C \leq 0,91$
F	$0,91 < C \leq 1,00$
G	$C > 1,00$

Table 5: Energy efficiency classes for washer dryers

Energy efficiency class	Energy consumption 'C' in kWh per kg complete operating (washing, spinning and drying) cycle using standard 60°C cotton cycle, and "dry cotton" drying cycle, determined in accordance with the test procedures of the standards referred to in Article 1 (2)
A	$C \leq 0,68$
B	$0,68 < C \leq 0,81$
C	$0,81 < C \leq 0,93$
D	$0,93 < C \leq 1,05$
E	$1,05 < C \leq 1,17$
F	$1,17 < C \leq 1,29$
G	$1,29 < C$

Conformity assessment and enforcement

The Directives are based solely on self-assessment by the manufacturer although supporting documentation is required.

Since the Directives are about the product information provided by manufacturers, the implementing regulations fall within existing consumer protection legislation dealing with the description of goods by those selling them, and enforcement is dealt with in the same way as for other retail complaints.

Work in progress

The Energy Labelling Directive 92/75/EEC is currently being reviewed by the EC in relation with the stakeholders. In this process, CECED submitted a position paper to the EC consultation document last 1 February 2008. It is noteworthy that CECED is supporting a label that should still maintain the focus on energy efficiency and energy during use but is advocating for a dynamic model, underlining that:

“for an energy label to have positive effects and make a real difference it has to be dynamic to accommodate future efficiency improvements. The label should provide the possibility of adding new energy efficiency classes on top to reflect technology developments. The future energy efficiency classes should be known in advance so industry has goal posts to aim at and a real incentive to continuously compete to bring the most efficient products on to the market. Such a dynamically evolving scheme would avoid the problems which occur with the current labelling scheme where, in a lot of product categories, most models on the market have already reached the top classes and there is no possibility to show further improvement (...).The presence of a top class, being updated as soon as innovation occurs or there is a sufficient uptake of the market, would respond to the request of showing the “best”.

Brief summary of other relevant Directives

Directive 2001/95/EC – The General Product Safety Directive

This Directive imposes a general safety requirement on any product put on the market for consumers or likely to be used by them, ranging from sports equipment, household products, to medical device equipment.

A safe product is one which poses no threat or only a reduced threat in accordance with the nature of its use and which is acceptable in view of maintaining a high level of protection for the health and safety of persons.

The Directive empowers Member States to establish requirements depending on the risk and hazard posed by individual products either being introduced within the European Union or already in circulation. Similarly, the Directive empowers Member States to take any necessary action to remove any "serious risk requiring rapid action". If a product poses a serious threat calling for quick action, the Member State involved immediately informs the Commission via RAPEX, a system for the rapid exchange of information between the Member States and the Commission to which applicant countries can also have access. The resulting actions may include, but are not limited to:

- An entire ban and recall where a "serious risk requiring rapid action" is identified;
- Information regarding such actions may be available to the general public;
- Ban on exporting the product from the EU to third countries Work is still being done by the EU on establishing a list of potentially dangerous products of European Union-wide concern, as well as establishing within the Member States means of monitoring and testing these products. The GPSD is a "per-product" format Directive, meaning that requirements and action required varies across products and is evaluated on a product to product basis.

Directive 90/396/EEC – The Gas Appliance Directive

This Directive aims to ensure a single Community market in appliances burning gaseous fuels by laying down the essential safety requirements and type-approval rules. It does not indicate how these requirements must be met, thus leaving flexibility to manufacturers as regards technical solutions to be adopted.

Appliances designed specifically for use in an industrial process are excluded from the scope of the Directive.

The Directive requires the CE mark to be affixed to gas appliances and to a list of other products (construction products, simple pressure vessels, personal protective equipment, toys, telecommunications terminal equipment, hot-water boilers, electrical equipment etc.) likely to fall simultaneously within the scope of several technical harmonisation directives.

The annexes to the Directive give details of the essential requirements, procedures for attestation of conformity, use of the "CE mark" etc. Gas appliances and fittings that comply with the Regulations will be presumed to comply with the Gas Appliances Directive and be entitled to free circulation throughout the European Union.

Directive 97/23/EEC – The Pressure Equipment Directive

The Pressure Equipment Directive (PED) 97/23/EC applies to the design, manufacturing and conformity evaluation process of Pressure Equipment, as well as Pressure Equipment Assemblies. This Directive aims to harmonise the national legislation of Member States concerning the design, manufacture, testing and conformity assessment of pressure equipment and assemblies of pressure equipment constituting an integrated whole. It seeks to ensure that the relevant equipment in the European Union (EU) and certain other associated countries, such as those in the European Economic Area (EEA), can be placed on the market freely.

It applies to equipment subject to a maximum allowable pressure greater than 0.5 bar (i.e. 0.5 bar above atmospheric pressure) that poses a hazard due to pressure. Products covered include: pressure vessels, heat exchangers, pressure gas cylinders, steam boilers, pipeline equipment, storage tanks and pressure relief devices (valves, regulators...)

On the basis of this classification, five categories of pressure equipment can be identified according to the risk and requirements are set for each category regarding sound engineering practice, requirements relating to design, manufacture and testing, conformity assessment and CE marking.

Directive 2004/108/EC – The Electromagnetic Compatibility Directive

The Directive relating to electromagnetic compatibility governs on the one hand the electromagnetic emissions of electrical and electronic equipment in order to ensure that, in its intended use, such equipment does not disturb radio and telecommunication as well as other equipment. On the other hand, it also governs the immunity of such equipment to interference and seeks to ensure that this equipment is not disturbed by radio emissions normally present used as intended. The main objective of the EMC Directive is thus to regulate the compatibility of all equipment put on the market regarding EMC.

The conformity assessment for apparatus involves Self-Declaration by the manufacturer, with the voluntary option of using a Notified Body in the assessment of the manufacturer's Technical File. A transition period is in place for two years since 20 July 2007 for equipment placed onto the Community market prior to that date, provided no changes are made to the apparatus or to declared specifications.

Directive 2006/95/EC – The Low Voltage Directive

This Directive seeks to ensure that electrical equipment within certain voltage limits both provides a high level of protection for European citizens and enjoys a Single Market in the European Union. It provides a conformity assessment procedure to be applied to equipment before being placed on the Market and Essential Health and Safety Requirements (EHSRs) which such equipment must meet either directly or by means of harmonised standards.

In respect of conformity assessment, there is no third party intervention, as the manufacturer undertakes the conformity assessment. However, there are so-called "Notified Bodies" under the Directive, which may be used to provide reports in response to a challenge by a national authority as to the conformity of the equipment.

For electrical equipment within its scope, the Directive provides the Requirements with respect to health and safety covering all risks, including the health aspects of emissions of Electromagnetic Fields, thus ensuring that electrical equipment is safe in its intended use.

Directive 2002/96/EC – The WEEE Directive

This Directive aims to prevent Waste Electrical and Electronic Equipment (WEEE) arising by encouraging the design and production of EEE which take into account and facilitate dismantling and recovery. It seeks to minimise the disposal of WEEE as unsorted municipal waste and to encourage reuse, recycling and recovery of WEEE by setting quantitative targets. Further, it looks to improve the environmental performance of all operators involved in the lifecycle of EEE. For that, the Directive sets requirements relating to criteria for the collection, treatment, recycling and recovery of WEEE and makes producers responsible for financing most of these activities. Retailers/distributors also have responsibilities in terms of take-back of WEEE and the provision of certain information.

It applies to the following EEE product categories: large and small household appliances, IT and telecommunications equipment, consumer equipment, lighting equipment, electrical and electronic tools (with the exception of large-scale stationary industrial tools), toys, leisure and sports equipment, medical devices (with the exception of implanted and infected products), monitoring and control instruments and automatic dispensers

The EuP Preparatory study – Lot 14 proposes a comparative study of the application of the WEEE Directive worldwide.

Directive 2002/95/EC - The RoHS Directive

This Directive aims to protect human health and the environment by restricting use of certain hazardous substances in new equipment and to complement the WEEE Directive. It covers the same scope as the WEEE Directive (except for medical devices and monitoring and control instruments). It also applies to electric light bulbs and luminaires in households.

From 1 July 2006, lead, mercury, cadmium, hexavalent chromium, polybrominated biphenyls (PBBs) and polybrominated diphenyl ethers (PBDEs) in EEE had to be replaced by other substances. However, as it is not always possible to completely abandon these substances, the Commission provides for a tolerance level of 0.1% for lead, mercury, hexavalent chromium, polybrominated biphenyls (PBBs) and polybrominated diphenyl ethers (PBDEs), and a tolerance level of 0.01% for cadmium. In addition, certain applications specified in the Annex to the Directive are tolerated.

The EuP Preparatory study – Lot 14 proposes a comparative study of the application of the RoHS Directive worldwide.

Other national legislation and regulation

Australia

In Australia, labelling and minimum energy performance standards (MEPS) programs are controlled by State rather than national legislation. The national (Commonwealth) parliament does not have the constitutional power to legislate in this area. There are no MEPS for clothes dryers.

Energy labelling was introduced in some states in Australia in 1986 and now all states have the necessary regulations in place. The program is co-ordinated by the National Appliance and Equipment Energy Efficiency Committee (NAEEEC). Major manufacturers and importers recognise the commercial value of energy labelling, and are generally very supportive of the program (Harrington 2004).

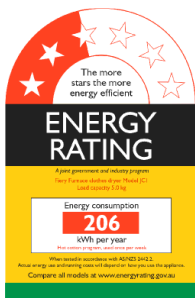

The Star rating scheme

To be eligible for an energy label, a clothes dryer must be able to dry a standard load in a single operation. Other requirements are a maximum clothes temperature limit of less than 130°C (to prevent scorching).

The energy consumption (CEC) of a clothes dryer is measured under conditions specified in standard AS/NZS 2442.

As for the “star” rating, the Base Energy Consumption (BEC), defined in the same standard, defines the “1 star” line for particular products. An additional star is awarded when the CEC of the model is reduced by a defined percentage from the BEC. The energy reduction per star is 15% for clothes dryers.

For clothes dryers, timer and autosensing models are treated slightly differently: timer models are given a 10% penalty on energy (and for the subsequent calculation of the star rating) on the basis that the way timer controls are used in normal practice results in some overdrying of the clothes load. Under the standard test, timer dryers are operated until the load reaches a final moisture content of 6% while autosensing dryers are operated until they terminate their drying automatically (but at a moisture content of less than or equal to 6%), so the tested difference is usually less than 10% (AG DEWHA no date a).

Recent developments

Industry/Government meeting

On 12 April 2007, key industry representatives met with AGO staff to discuss a range of issues, mainly relating to energy labelling and MEPS for whitegoods and air conditioners (e3 2007). Concerning clothes dryers, options for a revised algorithm were discussed, spurred by the possible availability of a heat pump dryer on the market which could impact on the range of star ratings available. Now, there is little data on actual use and this is required to revise algorithms; one option considered was for the label to show low usage and high usage. The key actions points were:

- Propose MEPS on standby for dryers which would be implemented as an adjunct to dryer energy labelling in order to deal with the issue in a timely manner.
- Recommend that water consumption be shown on the dryer energy label.
- Include Amendment 1 (just published for clothes washers) to permit harmonised revised load items to be used in Part 1 for dryers.
- Form a working group to cover off dryer testing issues.
- Implement a combined registration system for combination washer-dryers.
- Make sure that water consumption for dryers is displayed on the energy rating website and is in the CSV download file.

Proposal for extending the water efficiency labelling and standards (WELS) scheme to washer dryers and condenser dryers

The Water Efficiency Labelling and Standards (WELS) scheme enables the Australian Government, in consultation with the States and Territories, to set water efficiency labelling requirements and minimum water efficiency standards for products. At present the program covers clothes washers, dishwashers, showers, taps, toilets, urinals and flow controllers.

In November 2006 the Ministers of the Environment and Heritage Protection Council decided to explore, among others, the possible inclusion of washer/dryers and condenser dryers. This is under consideration (see for example Wilkenfeld 2007).

Standby power of clothes dryers

The inclusion of standby power measurement in the energy label for clothes dryers is under discussion (Harrington 2006). A “product profile” for clothes dryers on standby power was published in 2003 (NAEEC 2003) in this perspective.

Canada

The Energy Efficiency Act of 1992 and the subsequent Energy Efficiency Regulations set minimum energy performance levels for specified energy-using products and provide descriptions on the responsibilities of dealers of these products. Canadian MEPS have broad coverage, encompassing one of the largest ranges of products in the world. For major household appliances and room air conditioners, the Act and the Regulations also require dealers to attach an EnerGuide label to their product (NRCAN no date (a)). The Canadian system is the longest running formal energy labelling program in existence. The MEPS are the following:

Table 6: Minimum energy performance levels for clothes dryers in Canada

PRODUCT CLASS	MINIMUM EF May 1, 1995	
	(kg/kWh)	(lb/kWh)
Standard clothes dryer (125-litre capacity)	1.36	3.01
	December 31, 1998	
Compact clothes dryer (< 125-litre capacity)	(kg/kWh)	(lb/kWh)
120 V	1.42	3.13
240 V	1.31	2.90
Where EF = Energy Factor		

Source: NRCAN no date (b)

They apply to standard and compact electrically operated and electrically heated household tumble-type clothes dryers. The test standard is CAN/CSA-C361-92.

For washer dryers, the minimum energy performance levels are applicable since 1 January 2004 and are the same as for clothes washers for the washer component and the same as for clothes dryers for the dryer component (see above), measured according to the relevant test standard (CAN/CSA-C360-98 and CAN/CSA-C360-03 for washers and see above for clothes dryers).

These MEPS apply to integrated washer dryers, encompassing over/under washer-dryers and combination washer-dryers. An “over/under washer-dryer” is a household appliance that consists of a clothes washer component and a clothes dryer component located above, below or beside the clothes washer component, that is powered by a single power source and the control panel of which is located on one of the components. A “combination clothes washer-dryer” is a household appliance with a clothes washer function and clothes dryer function utilizing the same drum, a common control panel, and one power source (NRCAN no date (c)).

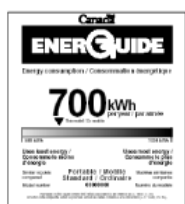

EnerGuide label for energy-using products

The EnerGuide scheme has both mandatory and voluntary labelling elements. For clothes dryers and integrated over/under washer dryers, the EnerGuide is mandatory. This applies to products manufactured after 3 February 1995 (or 31 December 1998 for compact clothes dryers).

The measures are made according to the same standard as for the MEPS cited above. A bar scale allows to compare the model's energy consumption to other models that are available in the marketplace and are part of the same test group. The energy consumption of the most energy-efficient model and the least energy-efficient model in the same test group – in accordance with the labelling scale published annually by Natural Resources Canada (NRCAN) are also displayed. (NRCAN no date (b)).

USA

The Energy Policy and Conservation Act (EPCA) of 1975 established an energy conservation program for major household appliances. Additional amendments to EPCA have given the U.S. Department of energy (DoE) the authority to regulate the energy efficiency of several products, including residential clothes dryers.

“Electric clothes dryer” under EPCA are defined as “a cabinet-like appliance designed to dry fabrics in a tumble-type drum with forced air circulation. The heat source is electricity and the drum and blower(s) are driven by an electric motor(s).” Gas clothes dryers would have a similar definition, but the heat source would be gas (U.S. DoE 2007).

The amendments to EPCA in the National Appliance Energy Conservation Act of 1987 (NAECA) established prescriptive energy conservation standards for residential clothes dryers, as well as requirements for determining whether these standards should be amended. On 14 May 1991, DoE published a final rule in the Federal Register (FR) establishing the first set of performance standards for residential clothes dryers; the new standards became effective on 14 May 1994.

The minimum energy factor (EF) for clothes dryers are expressed in cubic foot load capacity/kWh (also measured per cycle). The product is required to be tested in accordance with Federal test procedures to meet mandated efficiency standards. The test procedures can be found in the current U.S. Code of Federal Regulations (CFR, Title 10, Part 430 Appendix D). Gas clothes dryers manufactured after 1 January 1988 shall not be equipped with a constant burning pilot.

Table 7: Minimum energy performance levels for clothes dryers in the U.S.A.

PRODUCT CLASS	MINIMUM EF	
	(kg/kWh)	(lb/kWh)
Electrical standard (≥ 4.4 ft ³)	1.36	3.01
Electrical compact (< 4.4 ft ³ capacity)		
120 V	1.42	3.13
240 V	1.31	2.90
Gas dryers	1.20	2.67
Where EF = Energy Factor		

Source: U.S. DoE 2007

DoE initiated a second standards rulemaking for residential clothes dryers by publishing an advance notice of proposed rulemaking (ANOPR) in the FR on 14 November 1994. However, pursuant to the priority-setting process outlined in the 15 July 1996, Procedures, Interpretations and Policies for Consideration of New or Revised Energy Conservation Standards for Consumer Products (the “Process Rule”), DoE classified the standards rulemaking for residential clothes dryers as a low priority for its fiscal year 1998 priority-setting process. As a result, DoE suspended the standards rulemaking activities for them (U.S. DoE 2007).

As for test procedures, DoE established its test procedure for residential clothes dryers in a final rule published in the FR on 19 May 1981 and has not updated it since (contrary to the one for clothes washers, in 1997 and 2003).

The US DoE is currently leading a rulemaking process. A framework document was published in October 2007 (U.S. DoE 2007). The process is illustrated in the flow diagram below.

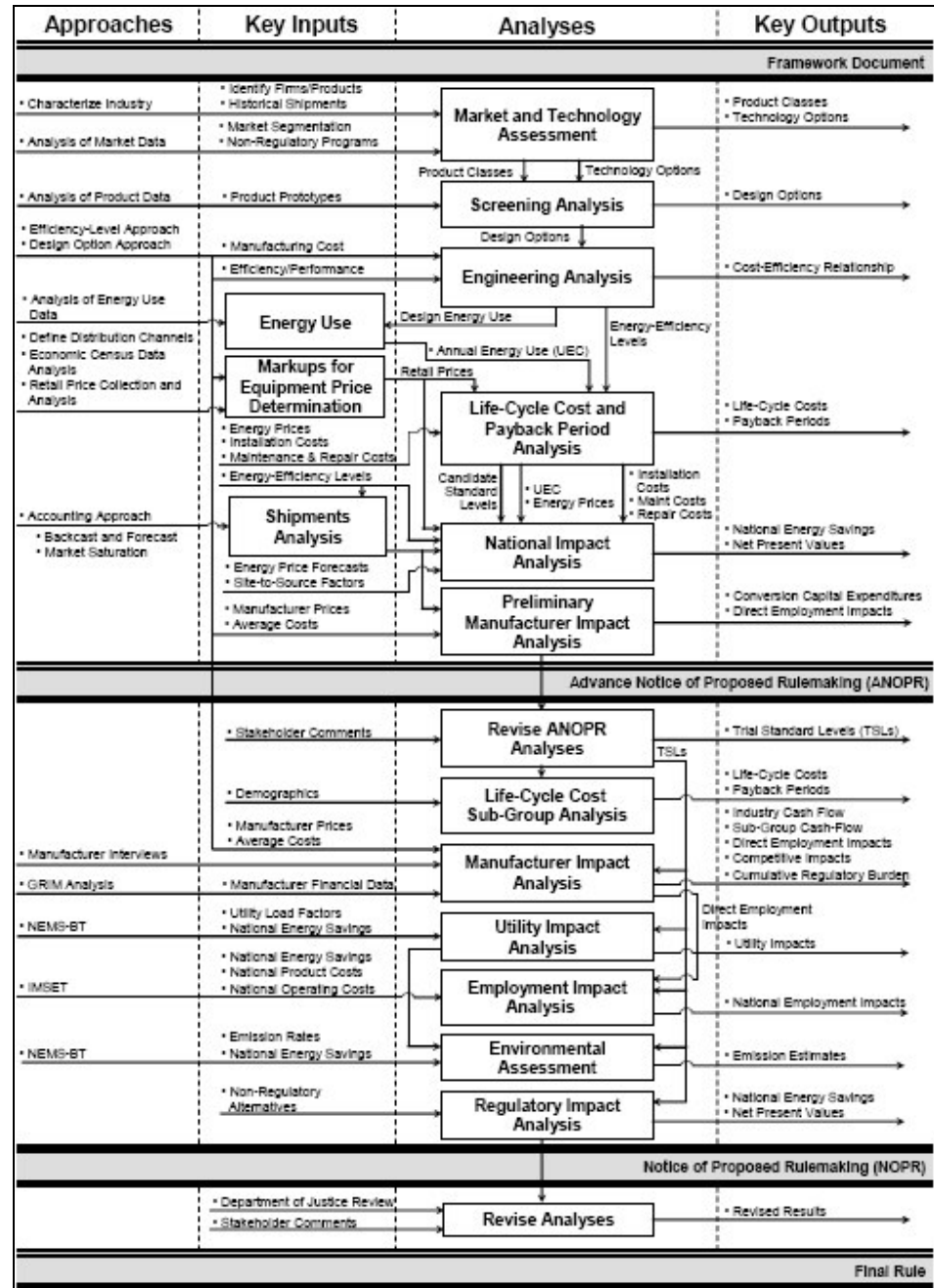

Figure 7: Flow diagram of analyses for the U.S. residential clothes dryers energy standards rulemaking process
 Source: U.S. DoE 2007

New Zealand

New Zealand, while setting programs independently, has worked in close conjunction with Australia when establishing its energy efficiency labels and standards. New Zealand's appliance and equipment energy efficiency programs are linked technically, commercially and administratively to those of Australia. The test procedures, comparative labelling and MEPS requirements for appliances are mostly contained in joint Australia and New Zealand's standards. For most products, the same manufacturers and importers supply both markets. On 15 May 2000, the NZ Parliament passed the Energy Efficiency and Conservation Act which gave the government the power to make labelling mandatory and set MEPS levels for a range of products. Mandatory labelling regulations became effective in April 2002 (Prior to 2002 this program ran on a voluntary basis but was identical to the Australian program). The Energy Efficiency and Conservation Authority (EECA) is responsible for implementing the energy efficiency and conservation policy (Harrington 2004).

E Voluntary initiatives

Australia

Top energy saver award winner (TESAW)



The Top energy saver award winner (TESAW) is a new award system (launched in 2004) that Australian and State governments along with the appliance industry have created to recognise the most energy efficient (best in class) star rated products on the market. It is complementary to the mandatory comparative star rating label.

It applies to both electric and gas products that carry a star rating energy label but there are separate TESAW labels for electric and gas appliances.

Each year, the energy efficiency of all products on the market will be reviewed. In consultation with the industry, the Government will set energy efficiency criteria (usually the best star rating available) for TESAW awards for the coming year (each label specifies the year of the Award). From the start of the award period (November), manufacturers of existing products or new products that meet the set energy efficiency criteria will be eligible to apply for an award. Once an award is granted, the manufacturer is eligible to display the TESAW label on their products in retail stores (AG DEWHA no date (b)).

Chinese Taipei (Taiwan)

The energy conservation label



To promote deployment of energy efficiency technologies and application of market incentive mechanism, as well as to encourage manufacturers to invest in research and development of high energy efficiency products, the Bureau of Energy of the Ministry of Economic Affairs (BOE) initiated the voluntary "Energy Label" program. Applicants determined to have met the requirements of energy efficiency criteria through the application review process are allowed to affix energy labels on qualified products.

The Energy Factor (EF) for Energy Label qualified clothes dryer products shall be measured under the test conditions and methodology approved by the energy regulating competent authority, and shall have a measured value of greater than 1.7 kg (clothes dried)/kWh (BOE no date).

The Green Mark



The Green mark Program of ROC (Taiwan) was launched in August 1992 by the Environmental Protection Administration. The program is developed to promote the concept of recycling, pollution reduction, and resource conservation. The objectives of awarding the Green Mark is to guide the consumers in product purchasing and to encourage manufacturers to design and supply environmental benign products.

For electric clothes dryers, the criteria are the following (EPA ROC no date):

- The product shall meet the requirements of CNS4673, C4141¹⁰.
- Energy Efficiency Factor (EF) of the product shall be no less than 1.7.
- Coating material used on the product shall not contain mercury, mercury compounds, or mixed with dyestuff containing lead, cadmium, hexavalent chromium, and their oxides. The product shall not have any organic solvent residue.

¹⁰ This standard is now revoked but no updated information on Green Mark requirements is available.

- The product and its manufacturing process shall not contain or use substances controlled by the Montreal Protocol, as well as contain toxic substances promulgated and controlled by the ROC Environmental Protection Administration.
- Plastic components of the product weighing 100 g or more, or with surface area equals to or greater than 100 cm², shall be marked with identification symbols.
- Plastic components of the product weighing 25 g or more shall meet the following requirements:
 - shall not contain cadmium, lead, hexavalent chromium or mercury;
 - shall not contain the following flame retardants:
 - polybrominated biphenyls, (PBBs);
 - polybrominated diphenylethers, (PBDEs): monobrominated diphenylether, dibrominated diphenylether, tribrominated diphenylether, tetrabrominated diphenylether, pentabrominated diphenylether, hexabrominated diphenylether, heptabrominated diphenylether, octabrominated diphenylether, nanobrominated diphenylether, decabrominated diphenylether.
 - chloroparaffins with 10-13 carbon atoms per molecule and chlorine content of greater than 50% by weight.

Similar products are considered the same, if they differ only in sizes or packaging weights.

UK

The energy saving recommended (ESR) label



The Energy Saving Trust (EST) is a non-profit organization funded by the British Government and the Private sector which develops and runs programs on behalf of the government and serves as a consultant. Their goal is to give consumers verified and unbiased information about the advantages of energetically sustainable products and services. It is also in charge of efficient product/services accreditation.

The ESR product labelling scheme highlights products that demonstrate best practice in terms of energy efficiency, thus allowing consumers to identify products that consume less energy more easily. The criteria are set so as to award the label to the top 20% energy efficient products, using the energy efficiency classes set in the EU Energy Labelling Directives as indicators. Products meeting set criteria are allowed to display the ESR logo in selling points and in promotional material.

The scheme aims to review the criteria as the efficiency of appliances improves, to maintain 'best practice' recognition for recommended appliances.

- In 2002, the criteria were set at A and B energy efficiency class.
- In February 2006, the criteria were revised to extend the scheme to include tumble dryers that were energy efficiency class C and used sensors to dry loads to a predetermined level. Any A and B models were still eligible. Using sensors is believed to prevent users from over-drying their loads, and many such dryers also offer the options of different levels of dryness to allow loads to be ironed.
- In February 2007, a category for gas-fired domestic tumble dryers was established as part of the ESR scheme.

Table 8: Criteria and certification required for the UK ESR scheme

Product	Electric domestic tumble dryers	Gas-fired domestic tumble dryers
ESR endorsement criteria	- EU Energy label rating A or B - EU Energy label rating C also permitted when combined with an automatic drying function (defined in accordance with Directive 95/13/EC)	- Primary energy consumption and carbon emission equal or better to EU energy label B (measured in accordance with BS EN 61121:2005)
Certification proof	- Energy Label A - C - Product declaration for C rated tumble dryers confirming that they have an automatic drying function.	- Independent third party test report - Self-declaration of compliance

Source: EST no date



Hong Kong: The Hong Kong voluntary energy efficiency labelling scheme (EELS) for electric clothes dryers

The EELS is an energy conservation initiative that the Government of the Hong Kong Special Administrative Region (HKSAR) has adopted. Under the scheme, common types of household appliances (including clothes dryers) and office equipment have to incorporate an energy efficiency label that serves to inform consumers of the product's energy consumption and efficiency. The scheme was launched on 28 December 1999 and energy labels will expire on 31 December 2008 when re-registration is necessary. It covers all new registered appliances imported to or manufactured in Hong Kong (with effect from the date that is declared by the participant) but does not cover second-hand products, those already in existing use, under trans-shipment or manufactured for export.

The scheme covers electrically operated clothes dryers that have a drying capacity normally not exceeding 10 kg for household use. Appliances that have larger capacity, or for industrial use, or those using non-electric energy sources are excluded. It also applies to household electric clothes dryers of the air vented and condenser types, with or without automatic stop function for the drying process, and incorporating a heating device but does not apply to clothes dryers of cabinet type in which the heated air is blown to dry the hanged clothes and is exhausted through an outlet channel. To make the concept of appliance energy efficiency more readily understood by ordinary consumers, appliance energy efficiency grade is introduced by linking the energy consumption index (percentage) to the 5 grades as shown in the table below, with Grade 1 being the most energy efficient and Grade 5 the least.

In Hong Kong, clothes dryers of European brands constitute up to almost 90% of the existing local market. In view of this market situation, the testing methodology is modelled in accordance with IEC 61121 standard.

Table 9: Conversion of energy consumption indices into energy efficiency grades for the Hong Kong EELS

Energy consumption index: I_e (%)	Energy efficiency grade
$I_e \leq 80$	1
$80 < I_e \leq 95$	2
$95 < I_e \leq 110$	3
$110 < I_e \leq 125$	4
$125 < I_e$	5

Source: EMSD HK2006

II Task 2: Economic and market data

II.1 Generic economic data

II.1.1 Drying machines market in Europe: production, import and export data

Production, import and export statistics are provided by Eurostat. Only a part of this data is available and details by countries are often missing. When data are incomplete, Eurostat does not publish an EU summary. It is therefore difficult to evaluate the apparent market at the European level. According to Williams (2003): "There are two reasons why expected data might not be found in Eurostats:

- The data is confidential. If only a small number of enterprises produce a product in the reporting country, there is a risk that information regarding an individual enterprise might be revealed. If the enterprise does not agree to this the reporting country declares the production figures confidential. They are transmitted to Eurostat but not published. However if several countries declare their production for a heading to be confidential, an EU total can be published because the data for an individual country cannot be inferred.
- The data is missing. There are a number of reasons why data might be missing: the reporting country does not survey the heading; the reporting country has reason to doubt the accuracy of the data and suppresses it; or the reporting country uses the wrong volume unit or the wrong production type, which means that the data is not comparable with other countries and is suppressed by Eurostat. If data is missing for one or more Member States the corresponding EU total cannot be calculated and is also marked as missing."

The following figures are split by Prodcom categories. They are the same as those shortlisted in Task 1. Abbreviations used are W for washing machines; W&D for machines which both wash and dry. It should be noted that only domestic tumble dryers are considered in the final scope of the study, but this task contains information on other types of products, information which were used to determine this final scope.

Table 10: Apparent EU25 consumption in units, 2005

EU25 total / 2005	Volume in Units			
	Production [1]	Import [2]	Export [3]	Apparent consumption [1]+[2]-[3]
29.54.22.30 W&D > 10 kg	39 987	16 772	31 786	24 973
29.54.22.70 Drying machines > 10 kg	36 723	NA	NA	NA
29.71.13.30 W Auto ≤ 10 kg incl W&D	17 539 087	2 445 721	7 045 683	12 939 125
29.71.13.50 W Non-Auto ≤ 10 kg incl W&D	4 636 716	270 323	104 600	4 802 439
29.71.13.70 Drying machines ≤ 10 kg	4 852 606	100 237*	517 491*	4 435 352*
29.56.21.00 Centrifugal dryers	NA	16 992	139 504	NA
29.56.22.50 Non domestic dryers	NA	NA	NA	NA
TOTAL	27 109 222	2 749 808	7 321 573	17 766 537

Source: Eurostat Prodcom data for EU25, 2005

* calculated using unitary value in Euros based on production units

Table 11: Apparent EU25 consumption in millions Euros, 2005

EU25 total / 2005	Value in million Euros			
	Production [1]	Import [2]	Export [3]	Apparent consumption [1]+[2]-[3]
29.54.22.30 W&D > 10 kg	209	9	107	112
29.54.22.70 Drying machines > 10 kg	258	19	131	146
29.71.13.30 W Auto ≤ 10 kg incl W&D	4 676	422	1 839	3 260
29.71.13.50 W Non-Auto ≤ 10 kg incl W&D	912	26	24	914
29.71.13.70 Drying machines ≤ 10 kg	964	20	103	881
29.56.21.00 Centrifugal dryers	19	1	3	17
29.56.22.50 Non domestic dryers	639	77	344	371
Total machines	7 678	576	2 613	5 702
29.54.42.10 Parts households or laundry type washing machine	127	28	174	-19
Total parts	127	28	174	-19

Source: Eurostat Prodcom data for EU25, 2005

The most significant household market, both in volume and value, corresponds to the Prodcom category 29.71.13: Cloth washing and drying machines, of the household type, which includes washing machines and machines which both wash and dry.

However there is no specific data regarding the particular machines which both wash and dry in the categories 29.71.13.30 and 50. Note that II.3.2 gives general sales data from GfK regarding the market share of wash and dry machines.

Household dryers with a dry linen capacity under 10 kg:
Production:
4.8 millions Units
Apparent consumption:
around 4.4 millions Units

For Prodcom category 29.71.13.70: Drying machines of a dry linen capacity ≤ 10 kg, Figure s indicate the production of 4.8 millions units in 2005 in the EU 25 (equivalent to a value of 964 millions Euros). Calculation based on a unitary price for 2005¹¹ demonstrate that exportation is quite significant, with more than 500 000 units sold out of the EU 25 in 2005. With an importation around 100 000 units, apparent consumption reaches 4.4 million units in 2005.

Production of appliances with a dry linen capacity superior to 10 kilos (Households laundry type washing machine including machines that both wash and dry and Drying machines) does not exceed 80 000 units per year and 600 millions Euros. Production volume data are not available neither for Centrifugal dryers nor Non domestic Dryers.

Nevertheless Prodcom category 29.56.22.50; Non domestic dryers (excluding those for agricultural products, those for wood, paper pulp, paper or paperboard) production reach

¹¹ Unitary price calculated using Eurostat production figures in volume and in value.

639 millions Euros. It shall be noticed that the definition of this Prodcod category is unclear. For this reason, a specific market analysis of Non-Domestic dryers is presented.

Finally, it is important to note that we have treated separately the so-called "parts of machines". However, those products could have been included in other categories, which could lead to double counting and a global overestimation of the Figure s.

II.1.2 Commercial/professional dryers market

The commercial dryers market is difficult to estimate. Few industrials are sharing out the market, and the data are therefore highly confidential and hard to collect. None association or counterpart of the CECED exist for commercial dryers at a European level. "Official" data on professional laundry machines – such as GFK database for domestic products - are neither available nor spread by manufacturers.

Professional tumble dryers are used by various type of clients, main uses are found in hospitals, hotels, laundrettes, apartment house laundries and commercial laundries.

We contacted three major manufacturers of commercial dryers. They explained that professional laundry is in general much smaller and fragmented than major appliances industry.

Based on manufacturers' internal market information, we have been able to estimate the following aspects:

- the world market volume of professional tumble dryers is around 85 000 units per year and the European market volume of professional tumble dryers is around 30 000 units per year. Moreover, one of the manufacturers estimated the European market value to approximately 200 millions Euros. An average price for professional dryers is difficult to obtain and/or calculate, therefore these Figure s are difficult to compare.
- this market is growing on average by 2% per year. Nevertheless, it should be noted that estimations varies up to 5% for one of the manufacturer. This could be explained by the different market positions in Europe among the manufacturers,
- around 70% of the European market is covered by products produced in Europe.

The main European countries using professional tumble dryers are the UK, Sweden, Denmark, Italy, Germany, France, and Spain. The main manufacturers producing professional dryers in Europe being Electrolux ELS (Sweden), Miele Professional (Germany), Ipsy (Belgium), Primus (Czech R.), Kannegiesser (Germany).

We also contacted various professional magazines as well as national professional associations such as the G.E.I.S.T. (Industrial firms of textile services French Group) but none of them was able to provide us with relevant market data for commercial laundry dryers.

European commercial
tumble dryers market:
27 900 units
1-2% annual growth

II.2 Market data for domestic dryers: sales analysis

II.2.1 Tumble dryers sales analysis

Methodological approach

This part of the report illustrates the sales data for electric and gas tumble dryers in Europe. The data have been provided by GfK firm. According to GfK, these data have a total market coverage of around 90%. It shall be reminded that GfK data are regarding only domestic dryers, i.e. of the household type.

The following countries are taken into account in the data set:

- Western Europe for 2002 to 2005: Austria, Belgium, Germany, Denmark, Spain, Finland, France, United Kingdom, Italy, Netherlands, Portugal and Sweden.
- Eastern Europe for 2004 and 2005: Czech Republic, Hungary, Poland, Slovakia, Bulgaria, Croatia, Romania, Slovenia, Ukraine
- Data for 2006 and 2007 are for EU 27 (excluding Baltic countries).

In the following tables, the products classified as “unknown” are products that were not classified by GfK in the past. Indeed, since 2005, the company started to code all the characteristics of the new products entering the market. That is why, from 2005, the part of unknown product is decreasing as old models disappear progressively from the market and, conversely, new ones enter the market.

Moreover, we had access to the results extracted from the 2006 CECED Model Database. This database inventories the different models of CECED manufacturers (1.313 models in 2006) so it is not a tool designed for global market analysis. Nevertheless, for some aspects presented below, we completed GfK information with statistics extracted from the CECED Model Database.

Global trends from 2002 up to 2007 for the European tumble dryers market

Table 12: Tumble dryers sales 2002 to 2007

Tumble dryers	Sales Units					
	2002	2003	2004	2005	2006*	2007*
Western Europe	3 356 978	3 289 002	3 641 564	3 668 333	NA	NA
Eastern Europe	NA	NA	29 435	38 419		
Total	3 356 978	3 289 002	3 670 999	3 706 751	3 956 589	3 816 915

Source: GfK, *: data for EU 27 (excluding Baltic countries)

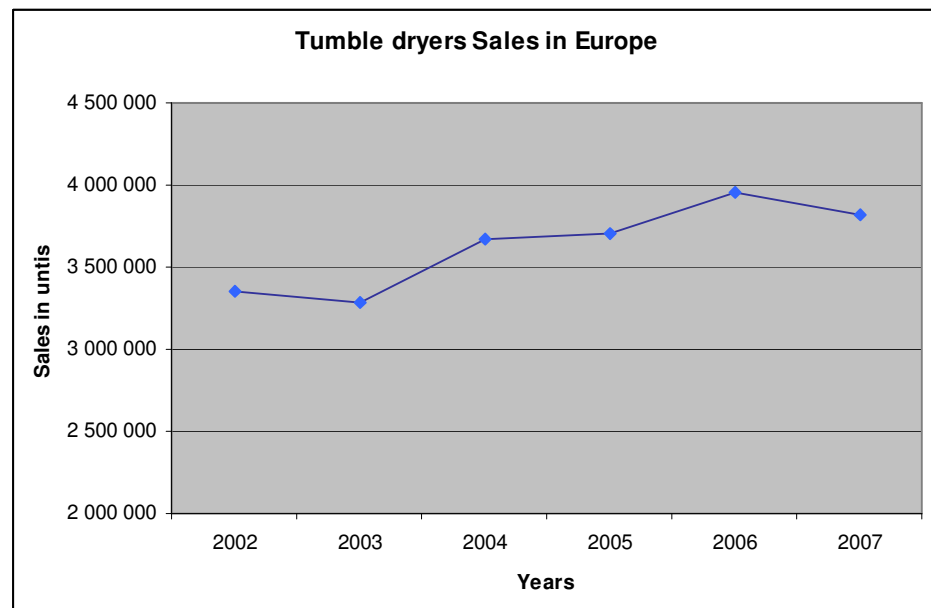

Figure 8: Tumble dryers sales in Europe, 2002 to 2007

An increasing market that suffers fluctuations with significant growths in 2004 and 2006 and a recent drop

Figure 8 indicates that the global European market of tumble dryers is globally increasing but has suffered uncertain evolutions in the last years. Indeed, there were two remarkable increments in 2004 (+ 12% compared to 2003) and in 2006 (+7% compared to 2005) but the market remained steady between 2002/2003 and 2004/2005. Recent evolution indicates a drop of 4% in 2007.

Over this period, between 2002 and 2007, sales have globally increased by 14%.

East Europe stands for only 1% of the global European market

In 2005, Eastern Europe was representing only around 1% of the total European market. However the increment of 2005 sales with respect to those of 2004 is around 30%: this remarkable growth entails that the Eastern market is relatively small so far but is rather dynamic.

In 2005 the sales for tumble dryers reached 3.7 millions units according to GfK data set that should have a global representativity of nearly 90% of the market (i.e. a global estimation of 4.1 million units sold for the whole Europe). This is smaller if we compare with the 4.4 millions units of apparent consumption¹² calculated with Eurostat data and tend to confirm that Eurostat data are likely to be overestimated.

¹² Domestic tumble dryers data provided by GfK are compared with the corresponding Prodcom category (29 71 13 70 : Drying machine with a dry linen capacity under 10 kilos) data of Eurostat.

Distribution of gas and electric tumble dryers sales in Europe

Table 13: Tumble dryers sales in EU 27 + Turkey, broken down by heating air systems, in units

	2006		2007	
	Sales Units	Sales %	Sales Units	Sales %
Electric	3 437 510	86.9%	3 559 502	93.3%
Gas	1 072	0.0%	533	0.0%
Unknown	514 527	13.0%	256 773	6.7%
Total	3 956 589	100%	3 816 915	100%

Source: GfK

Gas tumble dryers represent less than a percent of the total EU27 market of tumble dryers in 2007.

Overall, 2007 tumble dryers sales in EU 27 exceed the 3.8 millions units.

The Figure s indicate that the market is largely dominated by electric tumble dryers; they represent more than 93% percent of tumble dryers' sales in EU 27 with more than 3.5 millions units sold in 2007. According to GfK data, gas dryers seem to play a minor role in the tumble dryer market in Europe. However the fact that more than 250 000 units are still classified as "unknown" in 2005, should also be taken into account, consequently the number of gas dryer might be underestimated. Indeed, GfK data could be completed by manufacturer information, one of them mentioned 125.000 units sold in the last 18 years, around 7.000 units per year on average over this period of time.

According to industrial experts, market for gas dryers is increasing but it is not believed that they will gain significant market share in the next coming years.

Electric tumble dryers sales

In the following paragraphs, sales data are detailed and analysed considering:

- loading types (front/top),
- load capacities,
- technologies (vented/condenser),
- energy efficiency classes.

For Western Europe data, years 2002 and 2005 are compared, for Eastern Europe data 2004 and 2005 are compared because of the lack of data for year 2002 and 2003. It shall be reminded that Eastern European market represents only 1% of the global European market.

Tumble dryers sales by air technologies

Table 14: Sales by technologies, in units

Technology	Western Europe		Eastern Europe	
	Sales Units		Sales Units	
	2002	2005	2004	2005
VENTED	1 724 414	1 651 208	9 968	9 306
CONDENSER	1 632 564	2 017 068	18 234	28 933
UNKNOWN	NA	57	1 233	180
Total	3 356 978	3 668 333	29 435	38 419

Source: GfK

Table 15: Sales distribution by technologies

Technology	Western Europe		Eastern Europe	
	Sales Units		Sales Units	
	2002	2005	2004	2005
VENTED	51.4%	45.0%	33.9%	24.2%
CONDENSER	48.6%	55.0%	61.9%	75.3%
UNKNOWN	0.0%	0.0%	4.2%	0.5%

Source: GfK

Takeoff of the condensation technology since 2002

In Western Europe the two technologies used to share out the market rather equitably. However, between 2002 and 2005 air-vented tumble dryers market share dropped by 5% whereas condenser market share rose by 5% expressing the lift-off of the condensing technology. Industry experts confirmed this trend for more recent years estimating the overall share of condenser dryers to 60% in 2007.

In Eastern Europe, condenser tumble dryers were already dominating the market in 2005 reaching over 75% of the sales and with a significant increase of the sales (58% between 2004 and 2005).

In comparison, the CECED model database for 2006 Figures (however not weighted by respective sales) indicate a share of 64.4% for condenser dryer, which confirms the general trend.

Tumble dryers sales by loading types

Table 16: Sales by loading types, in units

Loading type	Western Europe		Eastern Europe	
	Sales Units		Sales Units	
	2002	2005	2004	2005
FRONTLOADER	1 192 047	2 862 021	17 835	33 173
TOPLOADER	86 401	73 385	66	169
UNKNOWN	2 078 530	732 927	11 533	5 076
Total	3 356 978	3 668 333	29 435	38 419

Source: GfK

Table 17: Sales distribution by loading types

Loading type	Western Europe		Eastern Europe	
	Sales Units		Sales Units	
	2002	2005	2004	2005
FRONTLOADER	35.5%	78.0%	60.6%	86.3%
TOPLOADER	2.6%	2.0%	0.2%	0.4%
UNKNOWN	61.9%	20.0%	39.2%	13.2%

Source: GfK

Front loaders lead the market, with over 78% of total European sales in 2005

The important share of "Unknown" loading type until 2005 allows to conclude on 2005 Figures only. Front loader dryers represent the majority of the sales in both Western and Eastern European markets with more than 2.9 millions sold units over 3.7 millions total sales.

Tumble dryers sales by loading capacities

Table 18: Sales by loading capacity, in units

Load capacity	Western Europe		Eastern Europe	
	Sales Units		Sales Units	
	2002	2005	2004	2005
<= 4,0 kg	251 981	225 375	1 598	584
> 4,0 <= 4,5 kg	175 601	42 971	181	197
> 4,5 <= 5,0 kg	2 114 582	1 181 726	18 485	10 024
> 5,0 <= 5,5 kg	337	829	0	480
> 5,5 <= 6,0 kg	806 390	1 899 294	8 828	25 345
> 6,0 <= 6,5 kg	0	19	0	0
> 6,5 <= 7,0 kg	1 591	272 523	194	1 545
> 7,0 <= 7,5 kg	251	41 459	11	225
> 7,5 <= 8,0 kg	9	0	0	0
> 8,0 kg	4 743	2 200	24	4
UNKNOWN	1 493	1 936	113	16
Total	3 356 978	3 668 333	29 435	38 419

Source: GfK

Table 19: Sales distribution by loading capacity

Load capacity	Western Europe		Eastern Europe	
	Sales Units		Sales Units	
	2002	2005	2004	2005
<= 4,0 kg	7.5%	6.1%	5.4%	1.5%
> 4,0 <= 4,5 kg	5.2%	1.2%	0.6%	0.5%
> 4,5 <= 5,0 kg	63.0%	32.2%	62.8%	26.1%
> 5,0 <= 5,5 kg	0.0%	0.0%	0.0%	1.2%
> 5,5 <= 6,0 kg	24.0%	51.8%	30.0%	66.0%
> 6,0 <= 6,5 kg	0.0%	0.0%	0.0%	0.0%
> 6,5 <= 7,0 kg	0.0%	7.4%	0.7%	4.0%
> 7,0 <= 7,5 kg	0.0%	1.1%	0.0%	0.6%
> 7,5 <= 8,0 kg	0.0%	0.0%	0.0%	0.0%
> 8,0 kg	0.1%	0.1%	0.1%	0.0%
UNKNOWN	0.0%	0.1%	0.4%	0.0%

Source: GfK

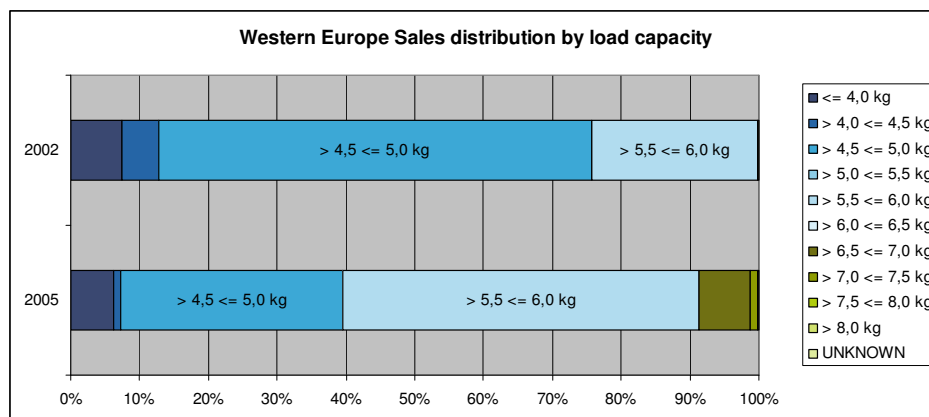

Figure 9: Sales distribution by loading capacity

The predominant load capacity rose of one kilo since 2002

Trends of loading capacity are similar in Eastern and Western Europe. In both cases, even if this evolution is faster in Eastern Europe, dryers with an average capacity between 4.5 kg and 5 kg, which used to represent two third of the market, drop to one third of the sales in favour of ones with a loading capacity between 5.5 kg and 6 kg, which reach more than half of the sales in 2005.

In the western European market, the loading capacity between 6.5 kg and 7 kg is significantly growing (+170% in comparison with 2002) reaching 7% of the market in 2005. Regarding more recent years, these trends and in particular the takeoff of the 6.5 to 7 kilos category, have been confirmed by Industry experts.

CECED model database 2006 Figure s (not weighted by respective sales) indicate the following shares: 27% for 5 kg load type; 50% for 6 kg load type and 17% for 7 kg load type, which confirms the general trend.

It shall be noticed that the sales of the lighter category (load capacity inferior to 4 kilos) remain nearly steady over the years. This trend can be explained by the fact that this specific category of dryer, because of its small dimensions, respond to a precise and constant consumer demand: small sized appliances because of the lack of room.

Tumbles dryers sales by energy efficiency classes

Table 20: Sales by Energy efficiency classes, in units

Energy efficiency class	Western Europe		Eastern Europe	
	Sales Units		Sales Units	
	2002	2005	2004	2005
A	13 318	16 957	17	178
B	3 742	17 758	1 209	76
C	2 661 650	3 288 241	26 505	37 176
D	409 658	213 100	844	703
E	15 360	12 789	35	10
F	107 480	93 461	0	0
G	20 233	1 374	0	0
UNKNOWN	125 536	24 653	825	276
Total	3 356 978	3 668 333	29 435	38 419

Source: GfK

Table 21: Sales distribution by energy efficiency classes

Energy efficiency class	Western Europe		Eastern Europe	
	Sales Units		Sales Units	
	2002	2005	2004	2005
A	0.4%	0.5%	0.1%	0.5%
B	0.1%	0.5%	4.1%	0.2%
C	79.3%	89.6%	90.0%	96.8%
D	12.2%	5.8%	2.9%	1.8%
E	0.5%	0.3%	0.1%	0.0%
F	3.2%	2.5%	0.0%	0.0%
G	0.6%	0.0%	0.0%	0.0%
UNKNOWN	3.7%	0.7%	2.8%	0.7%

Source: GfK

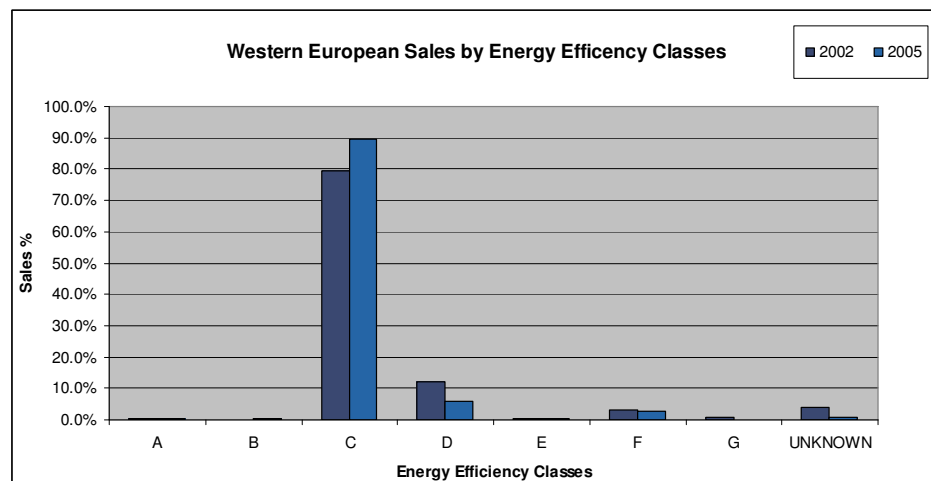

Figure 10: Sales distribution by energy efficiency classes, Western Europe

It shall be noticed that energy classes A+ and A++ do not exist for tumble dryers, the highest energy efficiency class being A.

The energy efficiency class C represents nearly 90% of the sales in Europe in 2005

Both in Western and Eastern Europe Energy efficiency class C is obviously prevailing. Figure 10 indicates a slight improvement, especially for Western Europe between 2002 and 2005 with a market share growth of 10% for the already predominating C class and a market share drop of 6% for the D class.

Moreover, even if A and B classes represent less than one percent of the sales, trends show a significant increase of the sales by 27% and 375% respectively between 2002 and 2005. According to industry experts, class B share on the market has been significantly increasing in recent years. The CECED model database 2006 Figure 10 (not weighted by sales) show a more important share for class B with a share of 15.5% (and 1.4% for class A).

In the Eastern European market, sales of energy efficiency classes F and G are null and the C class reaches 97% of the sales.

Following experts comments, it should be noted that technologies and load capacities are not equally spread in each energy efficiency classes:

There is only one model of air vented dryer in the energy efficiency class A in Europe and we are not aware of any model rated B.

In the UK, in 2007, the A-rated air-vented dryer represented 2/3 of the category A market, with heat pump dryers accounting for only 1/3. At the other end of the range, the majority of sales of D class dryers and all of the F class dryers were sub 4kg compact dryers.

South West and North West European sales analysis

In this paragraph data are broken down by region, Northwest gathering Austria, Belgium, Germany, Denmark, Finland, France, the United Kingdom, the Netherlands, Sweden and Southwest gathering Spain, Italy and Portugal.

Southwest European sales reach 457 982 units in 2005, gathering only 12.5% of the western market while they represent 27% of the western European households (according to Eurostat Figure s).

Regarding energy efficiency classes, it is important to note that class C is also widespread in southern countries (87%). However, the market share of classes D to G is relatively higher (11%) than in the case of northern European countries (8%). The higher part of class D dryers could be explained by the fact that the air vented technology is more widespread in southern countries than in northern countries.

Heat-pump tumble dryers

According to experts comments, heat pump tumble dryers reach nowadays a market share of 8% in Switzerland. However, they represent less than 1% of the overall European Market.

II.2.2 Washer-dryers sales

Table 22: Sales of washing-drying machines in Europe, in units

Washing-Drying Machines	Sales Units			
	2002	2003	2004	2005
Western Europe	549 933	550 163	587 161	583 452
Eastern Europe	25 007	44 132	40 684	52 318
Total	574 940	594 295	627 844	635 769

Source: GfK

GfK Figure s indicate that washer-dryers represent 15% of the machines (tumble dryers + washer-dryers) sold in 2005, with over 635 000 units sold in 2005 and an 11% growth since 2002 (+ 6% for Western Europe and +109% for Eastern Europe). This is coherent with CECED evaluation of the washer dryer market that represents 3 to 4% of the global washing machine market.

Recent trend seems to indicate that tumble dryer are growing faster than washer-dryers gaining market shares. Data provided by CECED Polska indicate a drop of the sales from 59% of washer-dryer (versus 41% of tumble dryers) in 2004 to 41% in 2008 (versus 59% of tumble dryers).

According to GfK data, European southwest countries are likely to consume less dryers and relatively less energy efficient ones than in Northern European countries

II.3 Market data: stock model

II.3.1 Stock estimation

Regarding stock data, information is not available through GfK and, in general, is not available in the statistical data per country. Nevertheless, installed base (“Stock”), historical and forecast data (stock, sales and energy consumption) can be evaluated through a model. We have mainly based our calculation methodology on two reports:

- EuP study - Lot 14: Domestic Washing Machines and Dishwasher; Task 2: Economic and Market Analysis, 2005
- Energy consumption of domestic appliances in European households Report: *Results of a stock model calculation including scenarios for future developments*, established by CECED and VHK in 2001.

A dynamic stock model: methodology

A “stock model” is defined as a mathematical representation of one or more characteristics of the products in use (“the stock”) in a specified time-period, as a function of the age these products¹³. Its general purpose is to show consequences of stock replacement. The stock model of this study is a dynamic stock model. This model is built from time series of input data, which allows the assessment of a non-linear age-distribution based on replacement sales and sales to new customers. Furthermore, it also incorporates a normal distribution (a waste curve) around an average product-life which gives a fairly good simulation of the end-of-life situation.

Input parameters

We based our analysis on the period 1975-2020 according to the results of 2001 CECED study that considered that before 1975 the ownership rate in EU 15 was zero.

The minimum input parameters needed for the period 1975-2020 are:

- the total market size, that is to say the total number of households (historical data until 2005 then estimates)
- the ownership rate that represents the household equipment rate (historical data until 2005 then estimates)
- the average product life (settled with industry experts on the basis of GfK data)
- the waste curve

In 2004 Europe enlargement introduces a scope modification, therefore “new” incoming countries (namely: Czech Republic, Estonia, Cyprus, Latvia, Lithuania, Hungary, Malta, Poland, Slovenia, Slovakia) will be considered separately from EU 15. Two different datasets will then be studied applying the same methodology.

Number of households and growth rates

Table 23: Eurostat data for households from 1998 up to 2006 (in thousand)

	1998	1999	2000	2001	2002	2003	2004	2005	2006
EU 15	141 514	142 194	143 529	145 217	148 846	152 268	153 505	155 972	158 231
Annual growth	NA	0.48%	0.94%	1.18%	2.50%	2.30%	0.81%	1.61%	1.45%
EU 25 – EU15	NA	NA	NA -	NA -	25 346	25 458	25 853	25 938	26 152
Annual growth	NA	NA	NA	NA	NA	0.44%	1.55%	0.33%	0.83%

Annual growth rates for household number:
West Europe: 1.5%
East Europe: 1%

¹³ Rainer Stamminger: Energy consumption of domestic appliances in European Households CECED

These Eurostat Figures allow to estimate the average annual growth of the number of households in Europe. Indeed, from 2005 up to 2020, an annual 1.5% yearly growth was assumed to be consistent with the latest trends.

For EU 15 countries, stock model inputs until 2000 are the same Figures used in 2001 CECED Report. The 2005 was corrected to 155 millions households in view of Eurostat dataset.

For Eastern Europe, Eurostat data were used from 2002 up to 2006 in order to firstly estimate annual average growth of the number of households, and secondly to assume 2000 data as well as to predict 2010, 2015 and 2020 data. Annual growth of the number of households was estimated to 1% in Eastern Europe (that is to say 2004 "new" incoming countries).

These trends leads to the following Figures for households from 1975 up to 2020, which are input parameters (historical or estimated) for the stock model.

Table 24: Households number input for the stock model (in millions)

	EU 15	2004 "new" incoming countries
1975	115.89	NA
1980	122.34	NA
1985	129.71	NA
1990	137.68	NA
1995	145.66	NA
2000	151.60	25.00
2005	155.97	25.94
2010	168.03	27.21
2015	181.01	28.60
2020	195.00	30.06

Ownership rates

The average penetration rate for Western Europe in 2005 is 34.4%¹⁴. Regarding East European countries this average ownership rate is supposed to reach around 1%.

Stock model inputs:

For EU15 countries Figures from the 2001 CECED Report were used in the stock model for the historical ownership rates up to year 2000. The ownership rate of 2005 was corrected to 34.4% regarding experts' data. From 2010 up to 2020 an average rate of 36% was considered so as to take into account the saturation of the West Europe market.

For "new" incoming countries an average 1% of ownership rate was used in 2005, estimations for 2000 and futures ownership rates are based on West Europe observations (+5% every 5 years). The following table sums up the ownership rates (historical and estimated) for EU 15 and new incoming countries.

¹⁴ Source: EMA_E_Business Intelligence

Domestic dryers
Estimated penetration
rate in 2005:
West Europe: 34.4%
East Europe: 1%

Table 25: Ownership rates input for the stock model

	EU 15	2004 "new" incoming countries
1975	2.0%	NA
1980	6.0%	NA
1985	10.0%	NA
1990	16.0%	NA
1995	22.0%	NA
2000	27.0%	0.5%
2005	34.4%	1%
2010	36.0% ¹⁵	5%
2015	36.0%	10%
2020	36.0%	15%

Past, actual and future stock estimation

The stock can then be estimated through the simple following formula for the year k:

$$\text{Stock (k)} = \text{Households (k)} \times \text{Ownership (k)}$$

Table 26: Stock results for the stock model (in millions units)

	EU 15	2004 "new" incoming countries
1975	2.32	NA
1980	7.34	NA
1985	12.97	NA
1990	22.03	NA
1995	32.05	NA
2000	40.93	0.13
2005	53.65	0.26
2010	60.49	1.36
2015	65.16	2.86
2020	70.20	4.51

The following graphics show the estimated evolutions of stock for both EU 15 and "new" incoming countries: they demonstrate the saturation of the Western market and the recent lift-off of the Eastern market.

¹⁵ Given the fact that saturation of the market is quite difficult to estimated, this parameter will be one of the criteria for the sensitivity analysis when improvement scenarios will be studied.

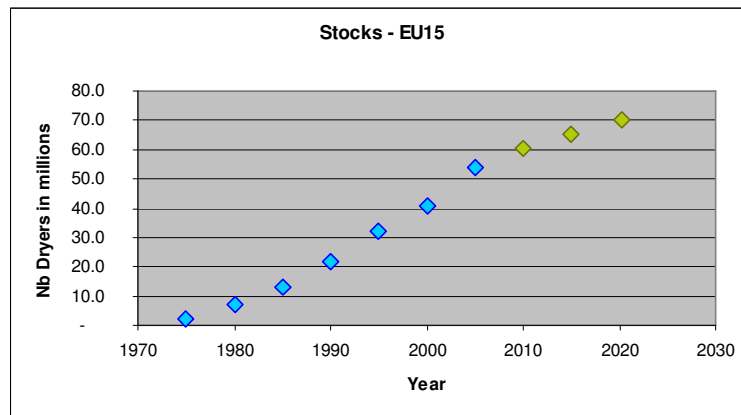

Figure 11: Stock evolution predicted up to 2020 for EU15

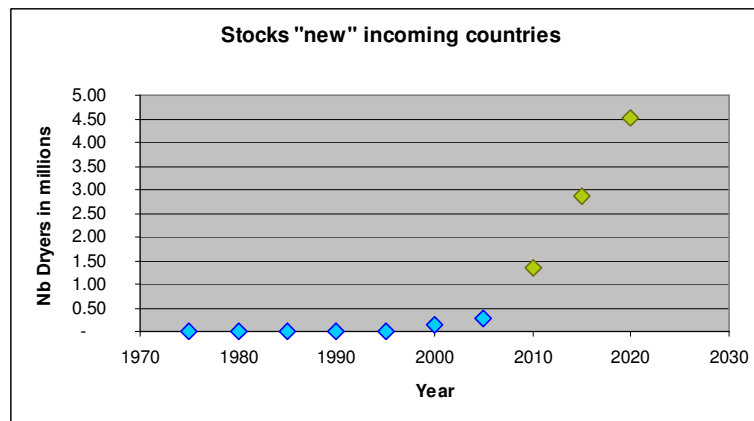

Figure 12: Stock evolution predicted up to 2020 for "new" incoming countries

II.3.2 Estimated sales

New Input parameters

Average product life

Following discussions with industry experts and based on GfK estimations, it was agreed that the average lifespan for laundry dryers considered during this project will be 13 years.

Average product life
13 years

Waste curve

It is assumed that average lifetime has a normal distribution with an average and standard deviation. In this study it was decided to use the 5 points given in the 2001 CECED Report so as to recalculate deviation and applying 13 years as average lifespan (as P hereinafter). Thanks to the least-square method the following deviation of 1.78 was assumed to be the deviation matching closely as possible to the points of the waste curve presented in 2001 CECED Report.

Table 27: Waste curve recalculation using 2001 VHK report

	Year	P-4	P-3	P-2	P-1	P	P+1	P+2	P+3	P+4
VHK 2001 report data	Nb Years	9	10	11	12	13	14	15	16	17
	Y(x)	2%	6%	14%	17%	22%	17%	14%	6%	2%
PwC recalculation	N(m,s)	2.00%	6.04%	11.23%	16.97%	21.99%	16.97%	11.23%	6.04%	2.00%
	s	1.83	5.78	2.70	2.10	1.81	2.10	2.70	5.78	1.83

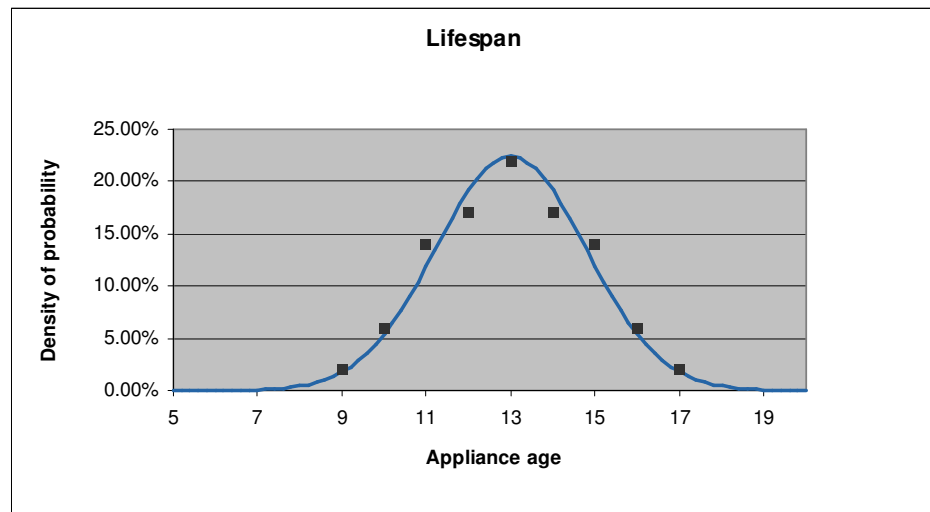

Figure 13: Drying machine Lifespan normal distribution

The following “Remain” function, is a probabilistic function that provides the share of appliances sold in the year j that are still working in the year k. The function is the integration of the above normal distribution.

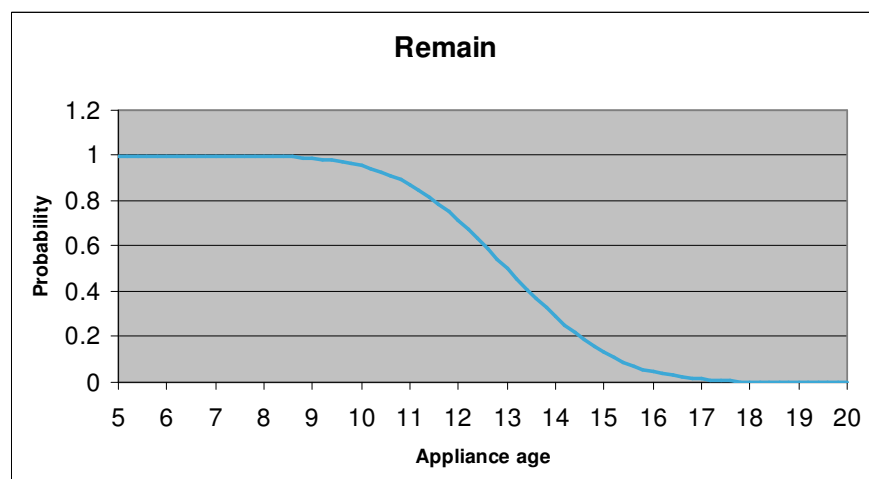

Figure 14: Drying machine Remain function

Sales estimations

These Remain function and the precedent stock estimations allows finally estimating sales through the following formula:

$$\text{ESTsales (k)} = \text{Stock (k)} - \sum_{i=i_0}^{k-5} \text{EST sales (i)} \times \text{Remain (i, k)}$$

In the following tables the indices i_0 are 1975 for West Europe and 2000 for East Europe. The time step selected is 5 years. As explained in 4.1, two sets of data are considered so as to take into consideration the scope change of 2004, between EU 15 and EU25.

Table 28: Estimated sales calculated through the stock model for EU 15 (in million units)

Years	Sales	1975	1980	1985	1990	1995	2000	2005	2010	2015	2020
1975	2.317	2.3	2.3	2.2	0.3						
1980	5.022		5.0	5.0	4.8	0.7					
1985	5.737			5.7	5.7	5.5	0.7				
1990	11.197				11.2	11.2	10.7	1.5			
1995	14.715					14.7	14.7	14.0	1.9		
2000	14.781						14.8	14.8	14.1	1.9	
2005	23.368							23.4	23.4	22.3	3.1
2010	21.096								21.1	21.1	20.1
2015	19.842									19.8	19.8
2020	27.178										27.2
Calculated Stock		2.3	7.3	13.0	22.0	32.0	40.9	53.7	60.5	65.2	70.2

Table 29: Estimated sales calculated through the stock model for new incoming countries

Years	Sales	1975	1980	1985	1990	1995	2000	2005	2010	2015	2020
1975		-	-	-	-	-	-	-	-	-	-
1980		-	-	-	-	-	-	-	-	-	-
1985		-	-	-	-	-	-	-	-	-	-
1990		-	-	-	-	-	-	-	-	-	-
1995		-	-	-	-	-	-	-	-	-	-
2000	0.125	-	-	-	-	-	0.1	0.1	0.1	0.0	0
2005	0.134	-	-	-	-	-	-	0.1	0.1	0.1	0.0
2010	1.107	-	-	-	-	-	-	-	1.1	1.1	1.1
2015	1.608	-	-	-	-	-	-	-	-	1.6	1.6
2020	1.826	-	-	-	-	-	-	-	-	-	1.8
Calculated Stock							0.1	0.3	1.4	2.9	4.5

According to this analysis, it is possible to calculate yearly trends for past and future estimated sales. For example, for the period 2000-2005, according to this stock model, around 4.6 million units sold per year were sold in EU 15. If we compare with GfK data for West Europe, the yearly sales trend for this period should be around 3.8 millions units sold. Nevertheless, this can be explained by two aspects:

- GfK data presented for the 2002-2005 period are in some way underestimated because they represent a total market coverage of around 90%,
- Moreover, the estimation of the stock also has a certain degree of uncertainty due to the difficulty to approach the real ownership rate.

II.3.3 Market trends

Regarding future trends, according to industrial experts, the main new technology that been be introduced recently and should gain market in the next years is the heat pump technology dryers. This trend would lead to the reduction of the global tumble dryers' energy consumption. A general reduction of the cycle time for the heat pump dryer could also be expected. Moreover lower drying temperatures of heat pump dryers may have an impact on the lifespan of fabrics by causing less damage.

Regarding aspects other than energy efficiency, the industry might improve the refrigerant gases use in heat pump dryers towards compounds that are more environmentally friendly. According to CECED manufacturer, the use of these new refrigerants might imply a reduction of the global warming potential (GWP) of the products and an increase of the efficiency of heat pumps.

In parallel, a higher penetration of gas dryers could cause the reduction of cycle time and energy consumption.

As a consequence, two major technological trends to consider are the increase of the loading capacity and the reduction of the time cycle, triggered by the industry for customers comfort. However, regarding conventional dryers, CECED manufacturers believe that the end of technological improvements has been reached.

As well as technological trends related to performance other trends related to the products that manufacturers use to market their goods – ease of use, noise emissions, speed of drying, additional functions i.e. wool baskets, trainer baskets, etc. may increase the total use of tumble dryers.

II.4 Consumer expenditure base data

II.4.1 Consumer prices analysis

This data set was provided by GfK. Prices were given by categories, for three different regions (South/North Western Europe and Eastern Europe). Average prices gathering different segments and/or regions are weighted by their respective sales.

Western Europe

Table 30: Prices of tumble dryers in West Europe, broken by technologies

Technologies		Western Europe			
		Unitary prices in Euros		Price trends	Sales trends
		2002	2005		
Air technology	Vented	273	257	-6%	-4%
	Condenser	496	451	-9%	24%
Loading type	Frontloader	381	363	-5%	140%
	Toploader	436	428	-2%	-15%
Energy efficiency classes	A	406	617	52%	27%
	B	449	670	49%	375%
	C	409	375	-8%	24%
	D	301	225	-25%	-48%
	E	339	347	2%	-17%
	F	190	180	-5%	-13%
	G	179	310	73%	-93%
	UNKNOWN	250	300	20%	-80%
Tumble Dryers	Average prices	381	364	-5%	-

Source: GfK

Western Europe:
Average price lowering by 5% from 381 to 364 Euros

Prices drop for condenser dryer and energy class C in parallel with significant sales increase of these segments

The average price of tumble dryers in Western Europe in 2005 is 364 Euros, this price dropped by 5% in comparison with 2002.

Regarding the western European market, data show significant fall of prices especially for:

- the condensation technology (-9% , with an average price of 451 Euros in 2005 which is still 75% more expensive than the air vented technology),
- Energy efficiency classes C (-8%) and D (-25%).

It should be noted, according to experts comments, that the price regarding D class may have fallen because all dryers sold in the D class are compact dryers, and not that the price overall of D class dryers has dropped.

These figures confirm partially the market trends, with the takeoff of the condensation technology and a significant increase of class C sales. Regarding class D dryers, even with the most important price's drop (-25% leading to one of the cheapest class with class F), sales fall as well by 48% between 2002 and 2005.

Prices have largely increased for energy classes A and B

Despite the fact that the prices of the highest energy efficiency classes (A and B) increase by around 50% (both exceed 600 Euros in 2005), sales of these categories increase largely, as seen in II.2.1. It should be noted that, according to industrial experts, average prices for class A dryers with heat pump are twice as important as class B dryers.

In general, prices given by GfK for energy classes A and B before 2005 might not be meaningful because the market volume for products with energy classes A and B was relatively low at that time (those figures have been highlighted in grey). Indeed, more accurate estimations from GfK for 2007 confirm that the average prices for class A are well above those of class B, by more than 30%.

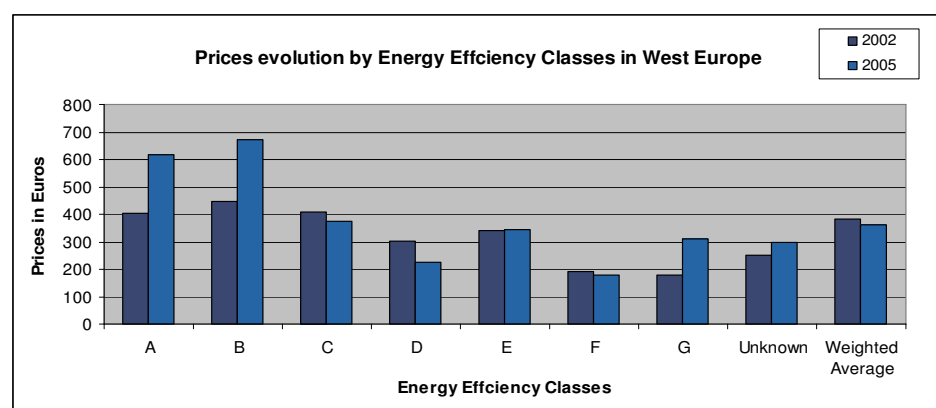

Figure 15: Prices comparison 2002 vs. 2005 by energy efficiency classes

Eastern Europe

Table 31: Prices by technologies, East Europe

Technologies		Eastern Europe			
		Unitary prices in Euros		Trends	sales trends
		2004	2005		
Air technology	Vented	274	296	8%	-7%
	Condensation	485	523	8%	59%
Loading type	Frontloader	405	473	17%	86%
	Toploader	290	429	48%	156%
Energy efficiency classes	A	355	732	106%	977%
	B	233	269	16%	-94%
	C	417	468	12%	40%
	D	383	435	13%	-17%
	E	341	204	-40%	-72%
	F	NA	NA	NA	NA
	G	NA	NA	NA	NA
	UNKNOWN	333	253	-24%	-67%
Tumble Dryers	Total	406	467	15%	-

Source: GfK

The average price is 467 Euros in 2005 (+15% in comparison with 2002), which is superior by 30% to the average European West market price. This could be explained by the fact that the eastern market is rather young, especially in 2005, therefore drying machines on these markets are considered “luxury” appliances” and purchased mainly by consumers with high revenues.

East Europe:
Average price increasing by
15% from 406 to
467 Euros

In Eastern European countries, prices increased significantly in general, it is noteworthy for top loaders (+48%) and class A (+106%) dryers between 2004 and 2005.

As stated for Western Europe prices, we detected that prices for energy classes A and especially B before 2005 might not be meaningful because the market volume for products with energy classes A and B was relatively low at that date (those Figure s have been marked with a grey colour).

II.4.2 Energy prices

Eurostat News Release 90/2006 and 93/2006, July 2006 are the sources for the following paragraph and tables.

Electricity prices

On average, electricity prices (all taxes included) for households in the EU25 rose by 4.6% between January 2005 and January 2006, leading to an average price of 14.16 Euros per 100 kWh. Over a longer time period, household electricity prices in the EU15 rose in total by 9% between January 2000 and January 2006.

EU 25, January 2006
Average Electricity price:
14.16 Euros/ 100 kWh

Price changes between January 2005 and January 2006 varied significantly between Member States. For households, the largest price rises were observed in Cyprus (+31.4%), Malta (+23.3%) and the United Kingdom (+14.2%), while prices remained stable in Latvia and Lithuania and fell in Belgium (-2.6%) and Austria (-5.2%).

In absolute values, household electricity prices were the highest in January 2006 in Denmark (23.62 Euros per 100 kWh), followed by Italy (21.08), the Netherlands (20.87) and Germany (18.32). The lowest prices were observed in Greece (7.01), Lithuania (7.18), Estonia (7.31) and Latvia (8.29).

When adjusted for purchasing power (PPS)¹⁶, household electricity prices in Greece (8.01 PPS per 100 kWh) remained the cheapest, followed by the United Kingdom (9.05), Finland (9.38) and France (10.92), while the highest prices were recorded in Slovakia (24.48), Italy (20.23), Poland (20.05) and the Netherlands (19.15).

Share of taxation vary
from 5% to 58%

The share of taxation in household electricity prices varied greatly between Member States, ranging from around 5% in Malta, the United Kingdom and Portugal to more than 40% in Denmark (58%) and the Netherlands (42%).

Average prices are significantly lower in the Eastern European countries (excluding Bulgaria and Romania as no data is available in 2006), 10.4 vs 14.84 Euros per 100 kWh. However prices tend to converge since new members States prices are growing at 11% per year versus 4% for the EU 15.

¹⁶ The Purchasing Power Standard (PPS) is an artificial common reference currency unit that eliminates price level differences between countries. Thus one PPS buys the same volume of goods/services in all countries

Table 32: Electricity prices per 100 kWh, incl. taxes

	Jan 2006 (nat. Currency)	% increase jan 2006/ jan 2005	Jan 2006 (Euros)	Jan 2006 (PPS)	% taxes
Belgium	14.42	-2.6	14.42	13.33	22.1
Czech Republic	283	7.6	9.85	15.81	15.8
Denmark	176.25	4	23.62	17.17	57.8
Germany	18.32	2.6	18.32	16.65	25
Estonia	114.4	7.8	7.31	11.78	15.2
Greece	7.01	1.9	7.01	8.01	8.3
Spain	11.47	4.6	11.47	11.95	18
France	12.05	0.9	12.05	10.92	24.9
Ireland	14.9	3.8	14.9	11.95	13.8
Italy	21.08	7	21.08	20.23	26.6
Cyprus	8.21	31.4	14.31	15.01	14.4
Latvia	5.77	0	8.29	15.37	15.3
Lithuania	24.8	0	7.18	13.77	15.2
Luxembourg	16.03	8.5	16.03	13.97	13.3
Hungary	26.95	2.7	10.75	17.14	16.7
Malta	4.07	23.3	9.49	13.26	4.7
Netherlands	20.87	7.3	20.87	19.15	42.2
Austria	13.4	-5.2	13.4	12.47	33.3
Poland	45.45	4.7	11.9	20.05	22.4
Portugal	14.1	2.1	14.1	16.3	5
Slovenia	2512	1.4	10.49	13.71	16.7
Slovakia	543	5.2	14.48	24.48	16
Finland	10.78	2	10.78	9.38	25
Sweden	133.59	5.7	14.35	12.06	39
United Kingdom	7	14.2	10.2	9.05	4.8
EU 25	14.16	4.6	14.16		

Source: Eurostat, Electricity prices in the EU in January 2006 " Household electricity prices rose by 5% in 2005, industrial prices up by 16%", news release, July 2006

Gas prices

Gas prices (all taxes included) for households in the EU25 rose by 16% on average between January 2005 and January 2006. Over a longer time period, household gas prices in the EU15 rose in total by 34% between January 2000 and January 2006. They followed the same pattern: a strong increase in 2000, four years of relatively stable prices and a further sharp increase in 2005. Over the same period, crude oil prices doubled.

All Member States are largely dependent on imported gas, except for Denmark and the Netherlands, which are self-sufficient, and the United Kingdom, which imports around 7% of the gas it uses.

Price changes between January 2005 and January 2006 varied significantly between Member States. For households, prices rose by more than 25% in Slovakia (+30%), Luxembourg and the Czech Republic (both +27%), Slovenia (+26%) and Ireland (+25%), while prices remained nearly stable in Estonia and increased by less than 10% in Denmark (+5%) and Italy (+8%).

EU25, January 2006
Average Gas price: 13.02
Euros/ GJ

In absolute values, household gas prices were highest in January 2006 in Denmark (29.82 Euros per GJ), followed by Sweden (25.95), the Netherlands (16.92) and Italy (16.50). The lowest prices were observed in the three Baltic Member States, Estonia (4.63), Latvia (5.34) and Lithuania (6.24). However, when adjusted for purchasing power, gas prices in the United Kingdom (7.30 PPS₄ per GJ) were the cheapest, followed by Estonia (7.47) and Luxembourg (9.00), while the highest prices were recorded in Sweden (21.81), Denmark (21.68), Slovakia (18.40) and Slovenia (16.97).

Taxation share between
5% and 56%

The share of taxation in gas prices varied greatly between Member States, ranging from around 5% in Portugal, the United Kingdom and Luxembourg to more than 40% in Denmark (56%) and Sweden (43%)

Table 33: Gas prices , January 2006 per GJ, incl. all taxes, for standard consumer 83.7 GJ/yr

	Jan 2006 (nat. Currency)	% increase jan 2006/ jan 2005	Jan 2006 (Euros)	Jan 2006 (PPS)	% taxes
Belgium	13.5	21	13.5	12.48	20.4
Czech Republic	287.97	26.8	10.03	16.09	16
Denmark	222.5	5.2	29.82	21.68	55.8
Germany	15.98	17.8	15.98	14.53	23.3
Estonia	72.52	0.1	4.63	7.47	15.1
Spain	13.63	14.5	13.63	14.2	13.8
France	12.72	20.3	12.72	11.53	15
Ireland	12.51	25.3	12.51	10.03	11.9
Italy	16.5	7.6	16.5	15.83	36.8
Latvia	3.72	17.7	5.34	9.91	15
Lithuania	21.54	15.3	6.24	11.96	15.2
Luxembourg	10.33	26.9	10.33	9	5.7
Hungary	1856.25	21.6	7.4	11.8	13
Netherlands	16.92	11.5	16.92	15.53	34.5
Austria	15.65	17.1	15.65	14.56	31.5
Poland	36.15	17.3	9.46	15.95	18
Portugal	14.52	17.7	14.52	16.79	4.8
Slovenia	3110	25.6	12.99	16.97	22.8
Slovakia	408	29.9	10.88	18.4	16.2
Sweden	241.6	20.4	25.95	21.81	43
United kingdom	5.65	11.4	8.24	7.3	4.8
EU 25	13.02	15.6	13.02		

Source: Eurostat, Gas prices in the EU in January 2006 " Household gas prices rose by 16% in 2005, industrial prices up by 33%", news release, July 2006

II.4.3 Repair and maintenance costs

Regarding repair and maintenance costs, little information is publicly available. We have found reference Figures from 2000 and published in the Test Magazine (07/2000).

In the following table, workforce and spare parts data represent the average cost of 6 German sales and customer services for 6 different models of drying machines. A seventh after-sales service is only offering an all inclusive fee.

Table 34: Average Repair and maintenance costs (in Euros) broken down by parts of drying machines

Machine parts	Workforce cost	Spare part cost	Total cost	All inclusive fee (One repairer)
Auto-timer	69	107	176	222
Motor	82	153	235	198
Moisture detector	50	23	73	96
Drive Belt	67	17	84	85
Overheating protection	51	14	65	74

Source: Test Magazine 7/2000, 2000

The costs presented above are average costs, it should be noted that, from an after-sale service to another, prices can vary from simple to double. Motor and Auto-timer parts are the most expensive parts to repair.

Additional information provided by experts allows comparison between Dryers and Washer-dryers: 'Which?' magazine suggests tumble dryers are quite reliable, but washer-dryers are less reliable, according to data gathered from surveys of products owned by 'Which?' members:

"Tumble dryers proved the most reliable of the washing appliances with only 1 in 10 of those less than 6 years old requiring repair. The top 3 reasons why tumble dryers break down are: Door - 16% of breakdowns; Element/heater fault - 15%; Thermostat - 14%.

Washer-dryers tackle two jobs in one appliance, but these multi-tasking machines have proven the least reliable home products in our survey; on average a quarter require repair in the first 6 years. The top reasons why washer-dryers break down are: Programme failure - 16% of breakdowns, Drain pump/hose - 12%, Door - 11%, Drum does not rotate - 11%" (Source: 'Which' website and reports)

II.4.4 Disposal tariff/taxes, Recycling systems and costs

Fares included in the consumer prices

The managing of recycling cost of laundry dryers is treated differently within Europe. Each country has its own approach when incorporating the costs of recycling. Usually the consumer pays a fare when buying the appliance. Specific information for the five following countries was provided by CECED.

Germany

In Germany the recycling collection for household appliances is regulated by the "Cost Ordinance on the Electrical and Electronic Equipment Act" and the "Electrical and Electronic Equipment Act, or ElektroG". The prices for the recycling of drying machines are clustered in a bigger group for the collection of household appliances. This price is open to negotiation between producer and contract partners.

Switzerland

In Switzerland a fare is included in the consumer price (11 CHF = 7 Euros for tumble dryers and 28 CHF = 18 Euros for heat pump dryers) in prevision of the later disposal (these Figure s apply for 2008, and are negotiated every year).

The Czech Republic

In the Czech Republic, there are both a "visible fee for old waste" (which is paid by consumers when disposing of the appliance) and a "fee for new waste" (included in the product price). Those fees are based on real costs: recycling and system costs (including transportation, collection, information...) The actual price of recycling in itself is close to null because the materials (mainly metals) gained from the procedure are valuable and bring incomes that compensate the recycling cost. However logistics costs are important.

Poland

In Poland, in the Recovery Organization (Elektroeko) set up by CECED Polska, disposal fees and recycling costs of drying machines are null, for the same reasons as explained above. However, if collection costs and logistics are taken into account, this cost is around 10 Euros per recycled unit.

Italy

In Italy, the recycling fee included in the consumer price for dryers is 5 Euros (the same as for the other wet appliances). For dryers this price might be over estimated compared to the real cost of the recycling process given the facility to disassemble it and the value of the materials which can be reused. The recycling fee is paid by the consumer when purchasing the product; it can be visible or not, depending on the manufacturer decision. The collection costs are covered by local councils. As drying machines were introduced on the Italian market only recently (2 years, saturation 1%), there is no data available regarding real recycling costs for dryers.

Six European recycling systems for Electric and Electronic Equipments

Another source of information is the document *The WEEE Directive: The UK experience*. Recycling system costs have been published for 6 European recycling systems in this report of the UK Parliamentary Sustainable Waste Group in 2006. These countries have their own national systems for the recycling of electronic and electric equipments. The cost range (system costs added to recycling costs) is from 1.9 Euros per kg for Belgium to 0.92 Euros per kg for Sweden, with a European average of 1.21 Euros per kg (arithmetic average for the six systems).

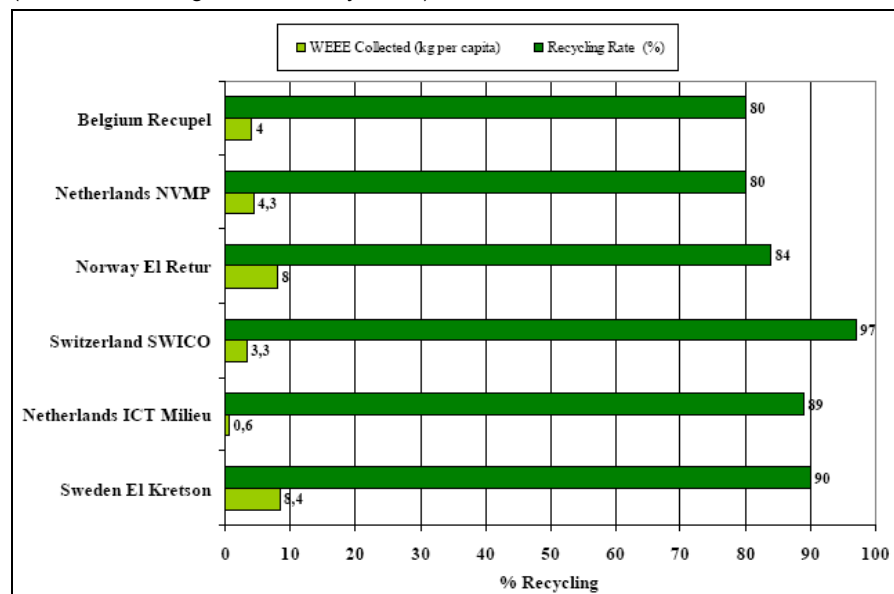

Figure 16: Recycling rates of existing European disposal systems for electric and electronic equipments

Source: M. Dempsey, *the WEEE Directive, the UK Experience*, APSWG, 2006

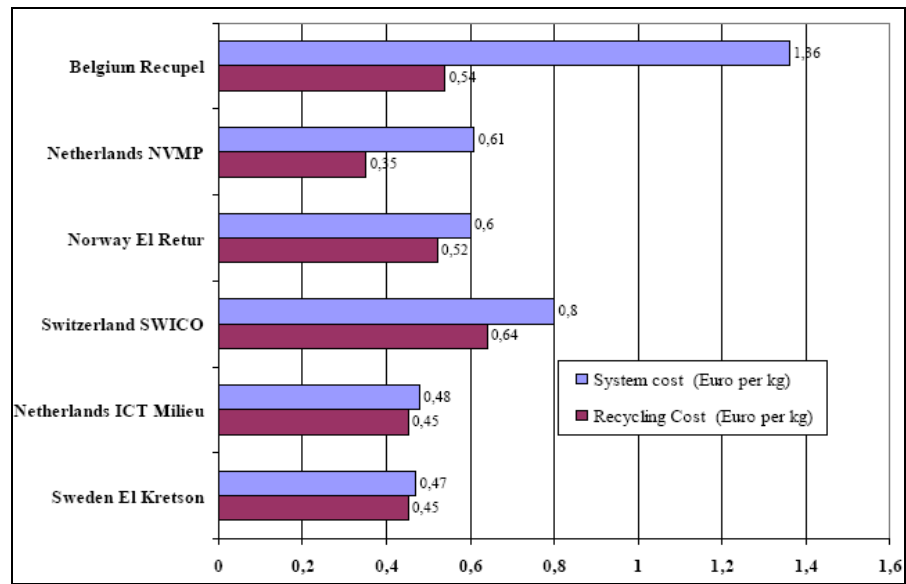

Figure 17: Economic costs of existing European disposal systems for electric and electronic equipments

Source: M. Dempsey, *The WEEE Directive, The UK Experience*, APSWG, 2006

Annexes to Task 2

F References

- GfK (2002-2007), *Retail Panel for tumble dryers*
- CECED (2006), *Model database for tumble dryers in EU25*
- CECED, VHK (2001), *Energy consumption of domestic appliances in European households*, Result of a stock model calculation including scenarios for future developments
- Öko-Institut e.V (2004), *Energy demand of tumble driers with respect to differences in technology and ambient conditions*, Final Report, commissioned by European Committee of Domestic Equipment Manufacturers (CECED), Freiburg, 13 January 2004, Authors Ina Rüdener, Carl-Otto Gensch
- Eurostat, *Electricity prices in the EU in January 2006*, news release, July 2006
- Eurostat, *Gas prices in the EU in January 2006*, news release, July 2006
- Test Magazine (2000), *Ich habe fertig*
- *Dempsey (2006)*, the WEEE Directive: the UK Experience, UK Parliamentary Sustainable Waste Group in 20

G Summary of comments from stakeholders

Submission	Comment	Response
04/06/2008 J.Nipkow/E. Bush S.A.F.E. (Schweizerische Agentur für Energieeffizienz)	<p>Heat pump tumble dryers were first developed in Switzerland many years ago and today reach a market share of nearly 8% (whereas in Europe <<1%).</p> <p>As their energy consumption is around 50 to 60% of a conventional tumble dryer, the efficiency is by far lower than the EU-energy label class A threshold. Unfortunately, some conventional dryers reached class B recently, buyers are confused as they assume that class B might be about in the middle of A and C, what is of course not the case</p>	<p>Added to the relevant section in the report</p> <p>Noted.</p>
04/06/2008 UK MTP (Market Transformation Programme)	<p>Section 3.1 Tumble dryers sales analysis: It is acknowledged that gas dryers have a small market share in the UK and EU. However, the report should also note other economies, such as the USA where sales of gas driers are much higher. Consumer Reports estimates that 20% of sales are of gas driers. Australian Greenhouse Office also has done some work thinking about the role of gas dryers as part of the switch to gas programme.</p> <p>Table 11 Sales by Energy Efficiency Classes & Table 12 Sales distribution by energy efficiency classes: The information in these tables would be clearer if they were disaggregated by loading capacity.</p> <p>A more detailed breakdown here by energy label class, washing and drying load sizes is expected here, and an introduction to the discussion of water consumption in the drying cycle should be included.</p> <p>In the UK in 2007 the majority of sales of D and all of the F class driers were sub 4kg compact types. Compact driers could also be a separate base case on the basis that they form a significant part of the market.</p> <p>Section 4 Stock model: The report should be clear about whether they are covering both tumble dryers and washer dryers and if both, the contribution of each type of appliance to the stock model. It is not clear as the document stands whether or not washer dryers are included; it is assumed that they are not but should be included. If compact driers are being considered as a separate base case, then the data for these should also be outlined.</p> <p>Section 5.2 Energy prices. If washer dryers are to be considered, then water costs need to be added to this section, particularly those country with the highest use of washer dryers.</p> <p>Section 4.3 UEC. Some of the detailed text in this section probably belongs in the Task 4 to 6 reports, not in this document. This section should lay very basic assumptions about ownership, frequency of use, load size, product lifespan, sales and historic trends of energy label classes, an output of the current stock model if there is sufficient agreed data to this. The discussions about the three scenarios should be saved for the improvement potential sections. However, there should be more about why the improvement potential is only related to the improvement in the spin speed of the washing machines, it is not at all clear from the text where this has come from or what it is to be used for.</p> <p>The discussions in the washing machine preparatory study suggest there may only be limited capacity or need for increased spin speed and spinning efficiency which is related to the uneven distribution of tumble driers throughout the EU member states, so not all tumble drier owners should be expected to have washing machines</p>	<p>Noted. The scope of the study is the European market.</p> <p>Noted. However GfK Figure s do not allow such disaggregation.</p> <p>Added to the relevant section in the report Remark: GfK Figure s do not mention “Compact dryers” as such but loading capacity under 4 kilos is represented.</p> <p>Washer-dryers are excluded from the scope of the stock model (Section 4)</p> <p>Noted. Noted but this will be comprised in later tasks. The potential improvement is not only related to spin speed since in the first column of the table the Unit average Energy Efficiency is evolving too.</p> <p>Noted.</p>

Submission	Comment	Response
	<p>with a lower spin speed in the future.</p> <p>Section 4.4 Market trends: Needs more on what drives people to buy dryers – lack of outside drying space, more working women, etc, and the responses of the laundry market including the relationship to the washing machine market – larger load sizes, higher washing machine spin speeds, increase in drying load in washer dryers etc, and where the researchers see these things going in future.</p> <p>So far as we are aware, heat pump dryers do not require a longer drying time than their traditional counterparts. This should be checked with the manufacturers. There are other factors related to the use of heat pump dryers such as lower drying temperatures that may have an impact on the lifespan of fabrics by causing less damage that could also be introduced here.</p> <p>This section should also look at the potential future trends in types of appliance i.e. condensing/vented, the role of compact dryers. The development of the market for dryers with sensors should also be discussed.</p> <p>As well as technological trends related to performance there are other trends related to the products that manufacturers use to market their goods – ease of use, noise emissions, speed of drying, anti-creasing technologies (?), additional functions i.e. wool baskets, trainer baskets, etc, some of which may increase the total use of tumble driers. Other, currently minor, technology impacts such as use of steam in the drying cycle (Electrolux) could also be mentioned.</p> <p>There could also be the start of the discussion of the trends that could impact on dryer usage i.e likelihood of use of drying cabinets (Maytag and Fagor) or rooms as in Switzerland.</p> <p>Section 5 Consumer prices: If possible, more analysis of the data underlying Table 24 should be done to draw out differences in the prices of different types of appliance i.e. by energy label rating and condensing/vented as well as full size and compact.</p> <p>Because the research has not differentiated information about compact driers from full-size driers the point about price drops in the D class may be incorrect. The price may have fallen because all that is sold in the D class is compact driers, not that the price overall of D class dryers has dropped. In the UK compact dryers all cost roughly the same – GBP115, but are cheaper than full size driers of any type or energy label class.</p> <p>The point on page 34 about the relative price of A class, B class and the rest of the market should be considered in the light of the changing nature of the A class market. While some heat pump models were undoubtedly sold in 2002, the proportion that were White Knight A class dryer would influence the average price. These are generally cheaper than heat pump dryers, so an increase in the proportion of A class that are heat pump would push the price up. The sales of B class models in 2002 were so low that the price may not be at all representative of the cost of the products. The price of B class driers is probably high compared to the average for C class because all of the B rated models are condenser types, which are usually more expensive than the vented models. Again, splitting the C class by condensing/vented types would clarify whether the drop overall in C class prices was encouraged by an increase in vented products or whether prices overall have fallen in that class</p> <p>Section 5.3 Repair and maintenance costs: The report needs to estimate the frequency of the repair. 'Which?' magazine suggests tumble dryers are quite reliable, but washer driers are less reliable from data gathered of</p>	<p>Noted but this will be comprised in later tasks.</p> <p>Noted and added to the relevant section in the report</p> <p>Noted but this will be comprised in later tasks.</p> <p>Added to the relevant section in the report</p> <p>Noted.</p> <p>Noted.</p> <p>Added to the relevant section in the report</p> <p>Noted.</p> <p>Noted and added to the relevant section in the report. This is also addressed in Task 3.</p>

Submission	Comment	Response
	surveys of products owned by 'Which?' members.	
<p>05/06/2008</p> <p>VDMA (Verband Deutscher Maschinen- und Anlagenbau, Germany)</p>	<p>Driers for industrial use in laundry technology are part of a comprehensive system that depends on a range of internal and external process parameters.</p> <p>Industrial drying machines can be broken down into the following general categories:</p> <p>Tunnel driers: Estimated number of units for the industry on European and US-market:10,000 - 20,000 per year</p> <p>Compact driers: For industrial use (over 10 kg) No sales Figure s available</p> <p>Finishers, drying cabinets: No sales Figure s available</p> <p>Mangles: No sales Figure s available</p> <p>Based on the approximate Figure s for tunnel driers stated above, the annual quantity of driers for private use is likely to be several times greater.The absence of sales Figure s suggests that the market share of industrial driers is minimal compared to that of household driers</p> <p>Private and industrial consumers decide whether or not to use a drier based on a range of key individual criteria and there are significant differences between the priorities of private households and industry.</p> <p>The key criteria for private use are energy efficiency, price and brand.</p> <p>The key criteria for industrial customers are: 1 Output, 2. Size of investment, 3. Consumption of resources</p> <p>Industrial driers are integrated into automatic processes, with technical availability and degree of utilisation both key factors.</p> <p>Unlike driers for private households, industrial driers cannot be considered in isolation since they are an integrated component of a complex system.</p> <p>Finishers, drying cabinets and mangles also fall into the industrial drier category.</p> <p>Here, unlike in tunnel and compact driers, the item of laundry is dried and pressed in the same process step. These different operational principles mean it is impossible to perform an analysis using the same parameters.</p> <p>The different types of heating used further underline the dissimilarity of the parameters for industrial and private driers:</p> <p>Private household: Electricity, gas</p> <p>Industry: Steam, gas, oil circulation (exception industrial compact dryers: Steam, gas, electricity, oil circulation)</p> <p>In our opinion a kWh/cycle consumption ratio permits no accurate conclusions to be drawn on actual energy or resource use. Depending on the prescribed internal or external process parameters a cycle can be long or short. Moreover, this definition also takes no account of residual moisture. Consumption expressed in kWh/l water or kWh/kg laundry would be a more objective measure.</p>	<p>Noted.</p>

Submission	Comment	Response
	<p>The design of industrial products tends to be tailored to the specific needs of the individual customer</p> <p>An examination of industrial drying machines under the EuP Directive would require a comprehensive system analysis. However, due to the complexity of the process for industrial machines outlined here there are no known standardised consumption measurement methods that are completely objective. For the same reason there are no (economically) meaningful, reproducible test methods in the industry for complete drying.</p> <p>An examination of driers for private households under the EuP Directive is useful due to the standardised parameters and above all to the presumably much greater market potential</p>	
<p>23/06/2008</p> <p>Federal Environment Agency of Germany</p>	<p>Market data for commercial dryers:</p> <ul style="list-style-type: none"> – If commercial and industrial dryers are not in the scope of the study, there is the danger that they will not be regulated, as it seems unlikely that an own preparatory study on commercial and industrial dryers will be commissioned. <p>However, energy efficiency requirements need to be set as well for these laundry dryers because of their higher use rate compared to household dryers.</p> <p>For example: not more than xy kWh per kg over all load classes which are not limited to 10 kilos.</p> <ul style="list-style-type: none"> – Efficiency requirements should be set with respect to the service provided by the product to the consumer and not according to different types of technologies or device types. The different types of technologies can be discussed under the focus of the same service. – With respect to different types of energy (gas and electricity) which are used for laundry dryer, we propose classifying the energy efficiency regarding the primary energy. – For consumers the relevant ratio is Euro/kg dried textiles (input/output). For environment policy the relevant ratio is environmental impact to service (input/ output). May be it is energy consumption during the use phase which causes the main important environmental impact of dryers. Therefore we propose to look on efficiency requirements formulated as kWh of primary energy per kg dried textiles. These requirements should be set for all devices which are used as laundry dryers – whether as sole dryers or in combination with other functions, e.g. as washer-dryer. Market Trends:: We welcome the use of more environmentally friendly refrigerant gasses for heat pumps used in laundry dryers by the industry. But we prefer a EuP regulation about these gasses. 	<p>Noted. This will be taken into account.</p>
<p>01/07/08</p> <p>Crosslee UK</p>	<p>The document states that “they [there?] are no Air-Vented dryers in Energy Efficiency classes A & B. This is not true. Whilst there is no CECED Air-vented dryer in classes A or B, the White Knight (Crosslee) cat A dryer exists as referred to in the submission by the MTP. This dryer is considerably cheaper than a heat pump condenser dryer. In the last 12 months, according to GfK Figure s, the White Knight cat A dryer has 2/3 of the UK cat A market with heat pump dryers accounting for only 1/3. I grant you that the cat A market is not huge in itself in the UK (or indeed across Europe as a whole), but it would certainly be wrong to assume that the growth in Cat A dryers is equal to the growth in heat pump dryers. We also export the cat A air-vented dryer to a nb of European countries.</p>	<p>Noted and added to the relevant section in the report.</p>

III Task 3: Consumer behaviour and local infrastructure

III.1 Objectives and Methodology

III.1.1 Objectives

Consumer behaviour can in part be influenced by product-design but overall it is a very relevant input in itself for the assessment of the environmental impact and the Life Cycle Costs of a product.

One aim of Task 3 is to identify barriers and restrictions to possible eco-design measures due to social, cultural or infra-structural factors such as lack of knowledge, convenience or force of habits as well as costs.

A second aim is to quantify relevant user parameters that influence the environmental impact of a product during its lifespan.

The purpose of this task is therefore:

- to collect data on how consumer behaviour can affect the performance of laundry dryers in terms of energy consumption and environmental impacts.
- to identify, on the manufacturer's side:
 - if they have relevant information about the behaviour of the consumers (criteria for buying decision, real life usage of their appliances)
 - how producers will or already integrate environmental issues in the design of their products
 - what type of environmental information they provide and how they communicate them to their customers
- to compare real life conditions with standard conditions in order to identify relevant elements to improve the environmental performance of the products.

III.1.2 Methodology

The methodology chosen to obtain the relevant information consisted in organising two series of surveys.

Manufacturer survey

A questionnaire was sent to several laundry dryers manufacturers (cf. [Annex](#)). This questionnaire was subdivided into two main parts:

“**Consumer behaviour**”, the objective of this section was to get an insight into how manufacturers:

- understand the level of environmental consciousness of an European consumer,
- analyse how an average consumer chooses and then uses an energy using product,
- have identified the potential and means to influence such behaviour in order to improve the energy efficiency and reduce the environmental impacts during the life-cycle of the product.

“**Information for consumers**”, the objective of this latter section was to better understand how manufacturers encourage environmentally friendly consumer behaviour (when behaviour can be influenced by the level of information provided).

This section tried to identify the kind and level of information communicated to consumers by companies through advertising, marketing, and/or in product brochures, user manuals, and other technical documentation.

Since the information obtained from manufacturers was confidential, the following analysis presents general results and trends rather than detailed answers.

Consumer survey

An Internet survey (cf. **Annex**) was carried out to obtain relevant data for this study. Its aim was to identify “actual” (or rather “declared”) consumer behaviour and consumer reactions towards EuP design options. Results from other studies on household appliances were added to complete the analysis. The following areas were investigated:

- Characterization of the stock of dryers: technology, top or front loading, capacity, availability of programs, runtime option (time or moisture controlled), etc.
- Declared consumer behaviour: location of the dryers, frequency of use (in summer, in winter), ventilation during drying, cleaning, behaviour at the end of the program, amount and type of laundry dried, program selection (type) and duration, additional features selected, use of consumables (wipes, etc), ironing program used (if chosen), etc.
- End of life behaviour
- Buying decision criteria
- Importance and means of information about environmental features

Most of these areas of investigation were identified as being relevant to explore for they may lead to energy savings and reduction of other environmental impacts. For example, the energy usage of dryers mainly depends on the following factors, which depend on the consumer behaviour:

- The actual loading of laundry v. its capacity (kg of laundry)
- The frequency of use (number of dry cycles per week)
- The use of certain dryer options such as the delay timer
- The “on button” mode (which represents the status of appliances at the end of a programme, while waiting for user attention)
- The way to use the washing machine (chosen spin speed)

III.1.3 Scope of the surveys

Participants to the consumer survey

The behaviour of consumers with domestic appliances, including laundry dryers, can tremendously influence the environmental impact of dryers. Although some studies on consumer behaviour with laundry dryers do exist, few are available in Europe, mostly due to the confidentiality of data (studies carried out by manufacturers or by external experts). Moreover those studies are neither complete nor updated and would not allow an actual assessment of the influence of consumer behaviour on the environmental impact of dryers.

The aim of this survey was to identify the “real life” behaviour of a large panel of consumers. It was carried out, with the support of an external market research Institute¹⁷, on 750 European households, aged 18 and over, in 3 European countries: France, the United Kingdom and Poland.

The countries were selected to represent three different areas of Europe with three different climatic zones and lifestyles:

- The UK Northern countries
- France Southern countries
- Poland Eastern countries

An added reason to select Poland was to take into account the behaviour of consumers from Eastern countries, considered as a new emergent European market, whose habits are less familiar to producers than those in Western countries.

The people were interviewed via an Internet questionnaire, online between 25 April 2008 and 29 April 2008. 86% of them (648 persons) use a laundry dryer. This rate was deliberately ordered to be high from the company conducting the survey in order to ensure relevant results for dryer owners, but yet include some votes from people frequenting launderettes. It must not be confused with the laundry dryer penetration rates previously given for each country.

250 households were interviewed in each country, selected to be representative of the population in the country and to fit within the scope and needs of this study. The following selection criteria and quotas were taken into account¹⁸:

- Not less than 50% female persons
- Not less than 50 % of persons own a dryer
- Selected age groups:
 - Under 18
 - Between 18-29 years
 - Between 30-39 years
 - Between 40-49 years
 - Between 50-59 years
 - Between 60-69 years
 - Over 70
- Household size: 1, 2, 3, 4 and ≥ 4 persons (up to 10 persons)

Most of the respondents are between 30 and 39 (25%), as can be seen in Figure 18, with no representatives of people under 18 and a low share over 70. Since the survey was conducted via Internet, younger people may be overrepresented. Do also refer to the section “Age of dryers” for the implications that respondents’ age has on the age of the dryers.

¹⁷ ODC Services GmbH, Munich (D)

¹⁸ This is consistent with the consumer survey carried for Lot 14 (on washing machines).

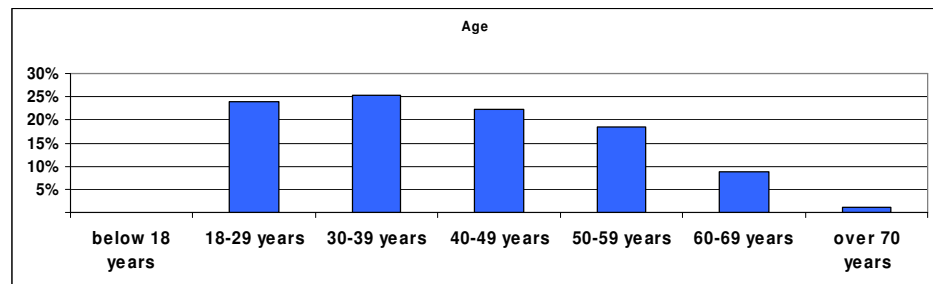

Figure 18: Age of the interviewed persons

On average, according to Figure 19, 62% of the respondents are female and 38% male. Those figures are consistent with other similar studies (e.g. EuP, Lots 13 and 14 where the proportions were 56% female and 44% male).

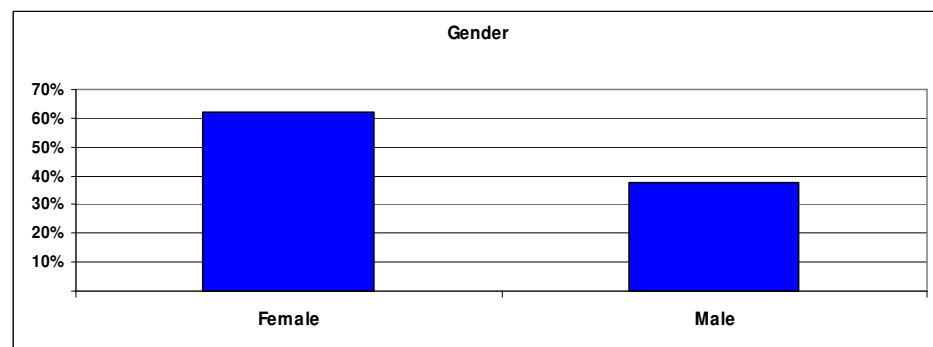

Figure 19: Gender of the interviewed persons

Participants to the manufacturer survey

In order to identify the knowledge of manufacturers about their consumers' behaviour and their strategy in terms of ecodesign and environmental communication, several producers from CECED¹⁹ and other associations (AMDEA²⁰) were selected to complete the questionnaire, representing a large share of the European Market:

- ARCELIK
- BSH
- CANDY
- CROSSLEE
- ELECTROLUX
- FAGOR
- GORENJE
- INDESIT
- MIELE
- V-ZUG
- WHIRLPOOL

III.1.4 Analysis of the results

It should be stressed that, since the results are based on the answers of consumers, the fact that some may have misunderstood questions or given incorrect answers due to wrong estimations has to be taken into account. Some figures may be challenged in the analysis, mainly for the reasons stated below. This is why an important work involving critical analysis, literature review and exchange with experts was carried out when analyzing the results. The main part of the report, diagrams, figures and comments are thus based on the consumer survey but information, arguments and diagrams from the

¹⁹ CECED: European Committee of Domestic Equipment manufacturers

²⁰ AMDEA : The Association of Manufacturers of Domestic Appliances (UK)

manufacturer survey were added to complete the analysis, where relevant. So as to differentiate diagrams based on the consumer survey from those based on the manufacturer survey, the backgrounds of the latter are yellow.

Range of answers

Due to the restricted knowledge of the survey participants, some questions allow only a range and no definite value for the answer. For example, the answer options for the question concerning the loading of the dryer were <3, 3-5, 6-8, 9-10 kg. The possible ranges can be weighted with different factors to yield an averaged value:

- At the bottom margin of the range (1.5, 3, 6, and 9 kg): average value of 3.6 kg.
- In the middle of the range (2.5, 4, 7, and 9.5 kg): average value of 4.5 kg.
- At the top margin of the range (3, 5, 8, and 10 kg): average value of 5.4 kg.

Here, the weighting factors in the middle of the range are used. For important questions regarding the definition of base cases also the bottom and top margin are given.

Difficulty of estimation

Some of the parameters queried from the survey respondents are difficult to estimate:

- Capacity and energy class of the dryer (if not known exactly)
- Average length of a drying cycle
- Average number of drying cycles in summer and winter
- Average dryer load

Measuring the exact average dryer load would e.g. involve weighing the laundry and recording the weight over a large number of drying cycles: hardly any end-user would take upon himself to do. All "average" values are thus estimates at best, and data from the industry and other sources should be considered when defining the base case.

Bias from respondent population

Even though, as explained in III.1.3, survey respondents were selected to be representative of average European households, there may be some bias due to the age of the participants, for example for questions on the age of dryers which may be underestimated here due to the age of respondents (the fact that it is an internet survey may have led to a larger proportion of young respondents).

Variability of answers

For questions with significant varying answers in the three considered countries the summarized results were weighted according to the population and the market penetration. These results are marked with the comment "(weighted result)" in the legend of the Figure . The following values are used for the calculation:

Table 35: Weighting based on the population and penetration rate of the 3 countries

	UK	France	Poland	Total
Population	60 209 500 ²¹	64 473 140 ²²	38 115 967 ²³	162 798 607
Penetration rate	42.40 ²⁴ %	34.60% ²⁵	5.00% ²⁶	
Dryer owner	25 528 828	22 307 706	1 905 798	49 742 333
Weighting	51.32%	44.85%	3.83%	

²¹ National Statistics

²² Institut National de la Statistique et des Études Économiques

²³ Central Statistical Office

²⁴ MTP programme BNW06

²⁵ GIFAM - France 2005, with a yearly increase of 2%

²⁶ CECEC Polska: the Polish national association of household appliances manufacturers

III.2 General results

III.2.1 Living conditions of the consumers surveyed

Dwelling type

Most respondents live in one-family houses (54%) or apartments / flats (33%) as shown in Figure 20.

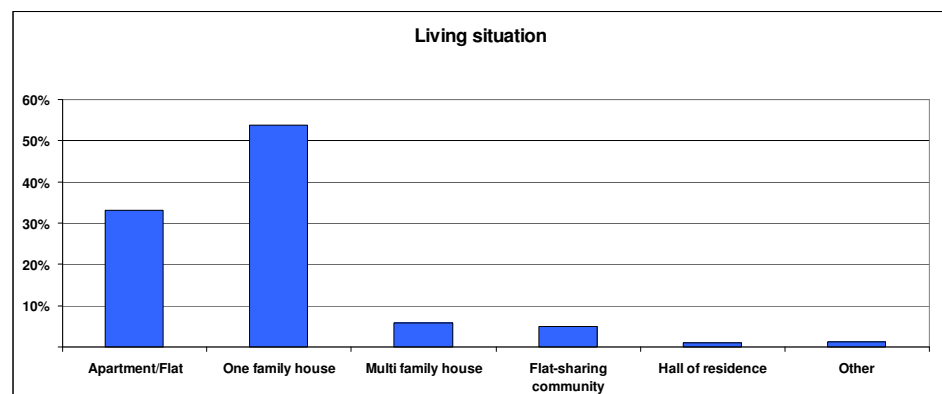

Figure 20: Dwelling type of the interviewed persons

According to Figure 21, 53% of people live in an apartment in Poland, while this concerns only 33% of respondents in France and 14% in the UK. It can be noticed that the share of “flat sharing communities” is around 15% in Poland, while being negligible in both other countries (1%).

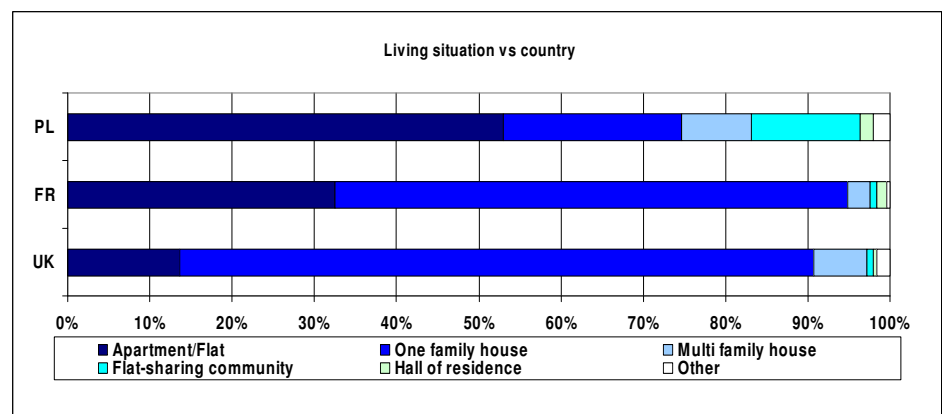

Figure 21: Living situation by country

Household size

Regarding the composition of the interviewed households, it consists of two to four persons, amounting to 74% of all respondents (Figure 22).

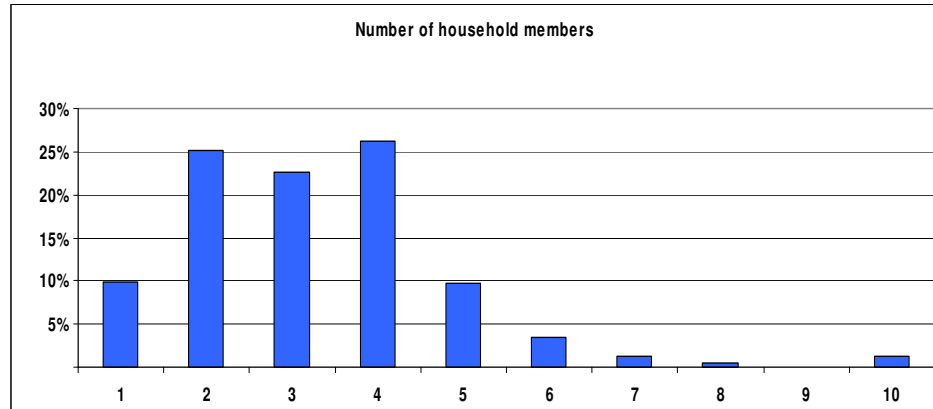

Figure 22: Number of household members

The average number of household members is between 2 and 4: 3,2

In details, depending on the studied countries (Figure 23), the share of the number of household members is similar in the UK and France with more than 60% with 3 persons. In Poland the ratio is more in favour of 4 persons.

According to the detailed data, the average number of household members is 3.2.

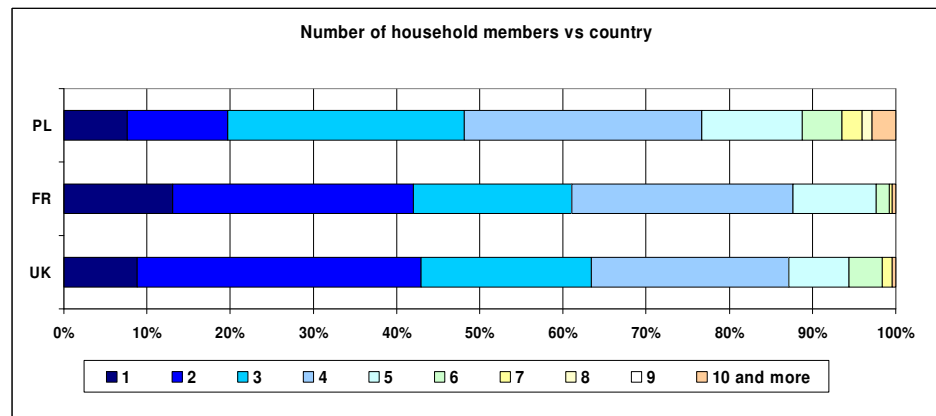

Figure 23: Number of household members by country

Sharing a dryer

Now, focusing on the situation where a dryer is shared between several households, it appears that 32% of respondents use their dryer in a laundry room without sharing the appliance, whereas 17% share it between two to three households (Figure 24).

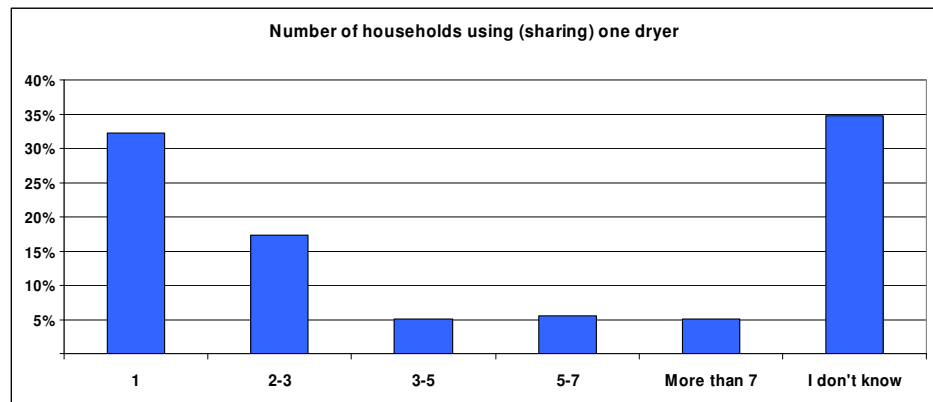

Figure 24: Number of households sharing one dryer

The ratio of shared dryers is a little bit larger in Poland. This is explained by more widespread flat-sharing communities and also, as shown in Figure 25, for the following reasons: restrictive spaces (31% of all respondents), cost reduction (31%) and energy efficiency (lowest ratio with 24% of all respondents).

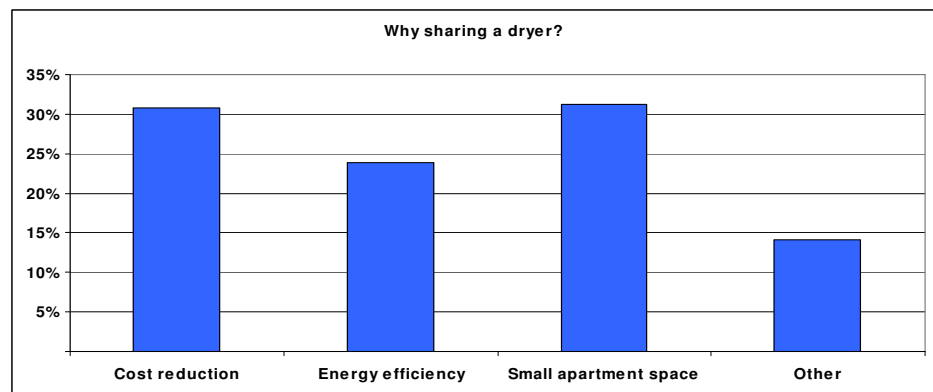

Figure 25: Reasons for sharing a dryer

Regarding the “other” reasons for sharing the dryer (almost 15% of answers), no specific trends have been highlighted by analysing the open question.

III.2.2 Characterization of the stock of dryers

Location

According to the consumer survey, laundry dryers are mainly located inside rooms (89%), more than half of which are unheated rooms (Figure 26). The outside location represents only 5% of answers.

89% of laundry dryers are inside rooms, more than 50% of which in unheated rooms

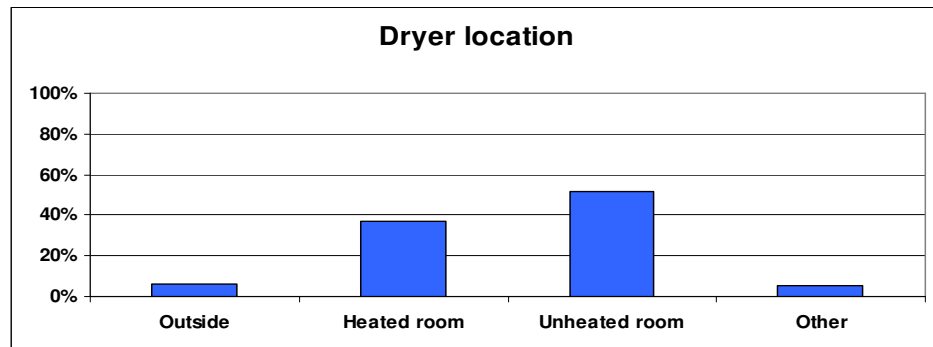

Figure 26: Dryer location at home (weighted results)

Heated rooms (37%) are generally located in the flat or in the house (e.g. a kitchen, bathroom or a utility room dedicated to laundry (laundry room)). Unheated rooms (52%) can be a garage or a cellar.

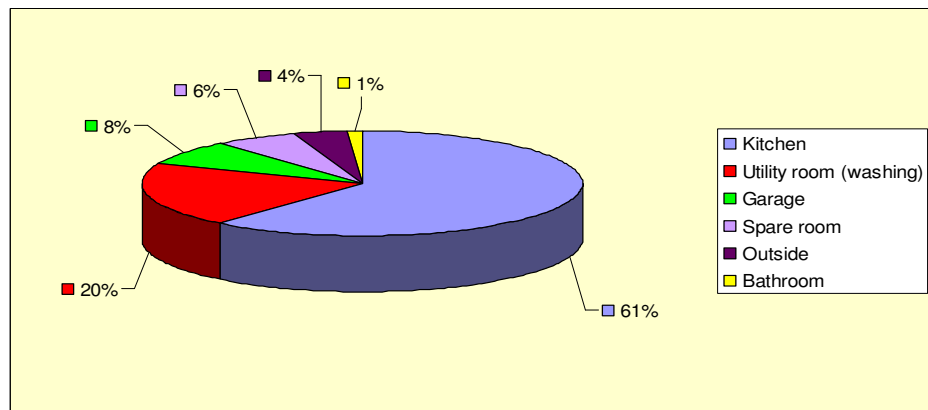

Figure 27: Main locations of laundry dryers (according manufacturers)

The manufacturer survey actually reveals great differences of habits between countries. The most common locations for laundry dryers, in order of importance, are for example:

- Spain, Portugal and the UK: kitchen, washing room
- France and Italy: bathroom, laundry room, kitchen then also cellar or garage (basement of the house)
- Germany: mainly cellar, spare room
- The Netherlands: spare room

Most laundry dryers being used indoors, the ventilation of the dedicated space is an important parameter in the calculation of energy consumption for the whole system (in Task 4, the use phase of the whole system will be taken into account and not only that of the dryer).

Regarding the results as displayed in Figure 28, it appears that 65 % of the rooms are naturally ventilated (through a window or a door for example). 21% of the answers concern mechanical ventilation, including fans and air conditioning for example.

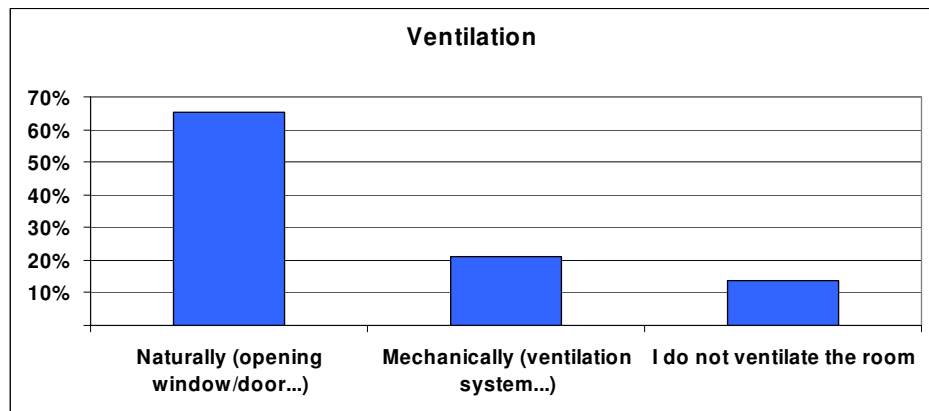

Figure 28 Ventilation of the space where the dryer is located

Type of dryers and loading possibilities

For consumers using dryers in winter and sometimes in summer (particularly in France then in the UK), the question is to know the most common type of dryer which is used.

The most widespread technologies are electric air vented tumble dryers (45%)

According to the results, by taking into account the dryers penetration rates in each country, the most widespread technologies are electric air vented tumble dryers (45%), air condenser tumble dryers (28%), combined washer-dryers (14%) totalling 86% of the sample (Figure 29). 11% of the respondents do not know the type of their dryer.

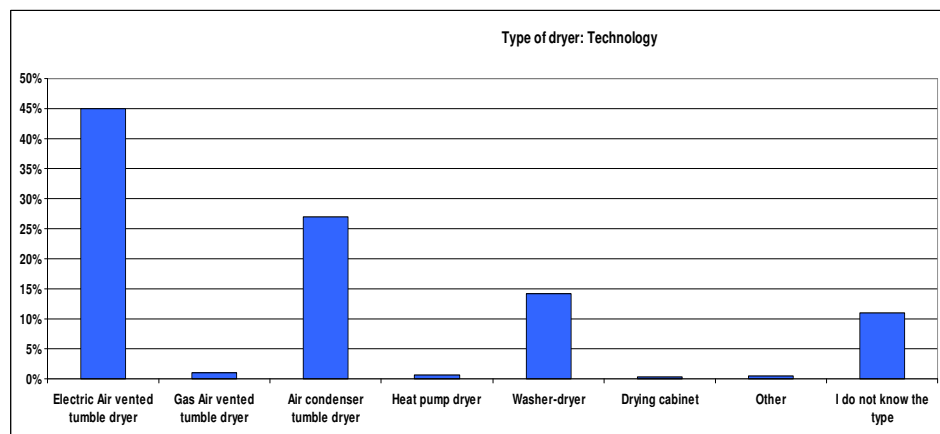

Figure 29: Type of dryer technology (weighted results)

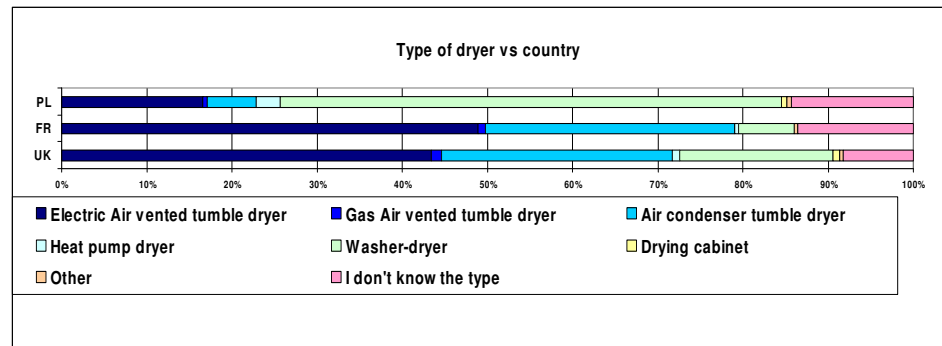

Figure 30: Type of dryer by country: technology

Depending on the country, the most commonly used type of dryers, as shown in Figure 30, are:

In the UK:

- Electric air vented tumble dryer (43%)
- Electric air condenser tumble dryer (27%)
- Washer dryer (18%)

In France:

- Electric air vented tumble dryer (49%)
- Electric air condenser tumble dryer (30%)
- Washer dryer (7%)

In Poland:

- Washer dryer (59%)
- Electric air vented tumble dryer (17%)
- Electric air condenser tumble dryer (5%)

These detailed results confirm that the major type of dryers on the market could be the air vented technology (particularly in Western Europe). Nevertheless, regarding this trend, it must be stressed that 11% of respondents do not know the type of their dryers.

The use of washer-dryers in Poland may be explained by space constraints, in small flats / houses where it is not possible to install both a washing machine and a laundry dryer in a bathroom or a kitchen.

Front loaders represent 91% of the consumers' dryers

Regarding the type of loading (front versus top), it comes that front-loading dryers (91%) vastly outnumber top-loading dryers (Figure 31).

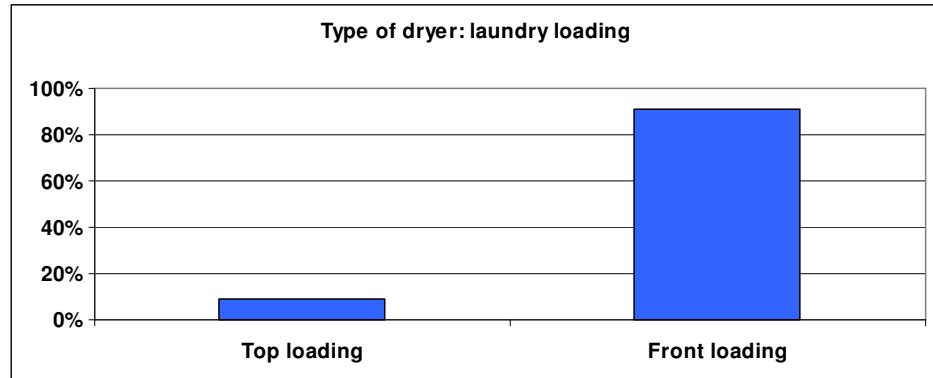

Figure 31 Type of loading (weighted results)

In details, depending on the countries (Figure 32), the same conclusion can be drawn to explain the 32% of ratio for the top loading appliance: space constraints.

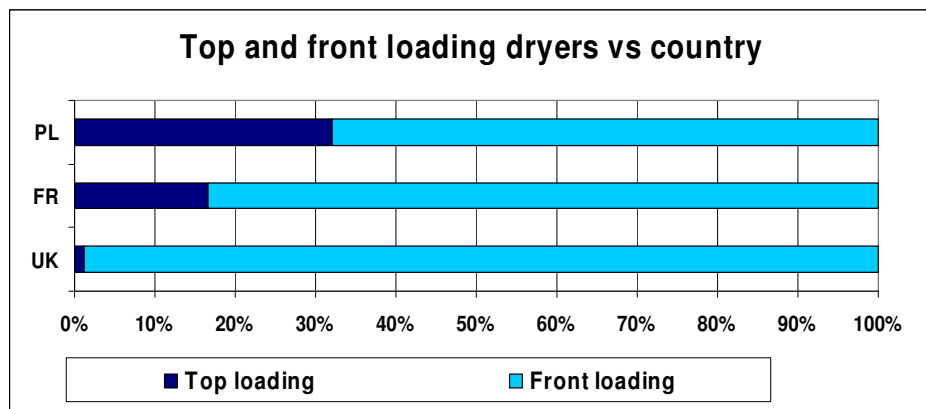

Figure 32: Type of dryer by country: laundry loading

These results are confirmed by the manufacturers' answers.

According to the manufacturer survey, the air vented tumble dryers are produced by all the manufacturers, while heat pump and gas dryers and drying cabinets represent a small share of producers.

By comparing both survey results, for the air vented and condenser technologies, it appears that more consumers use air vented dryers than air condenser ones, Figure s which could explained by the smaller share of manufacturers producing appliances with condensation technology.

Now, market data have shown (as seen in task 2) that the sales tendency is evolving in favour of the condenser technology, particularly in Eastern Europe:

Table 36: Sales distribution by air technologies for tumble dryers

Technology	Western Europe		Eastern Europe	
	Sales Units		Sales Units	
	2002	2005	2004	2005
VENTED	51.4%	45.0%	33.9%	24.2%
CONDENSER	48.6%	55.0%	61.9%	75.3%
UNKNOWN	0.0%	0.0%	4.2%	0.5%

Source: GfK

Indeed, between 2002 and 2005 in Western Europe, the market share indicates a larger penetration rate of the condenser technology. Comparing these Figures to the results of the consumer survey, it could be argued that a large share of people could have bought their dryer before (or shortly after) 2002.

For washer-dryers, the consumer survey shows that this technology ranks third in Europe (14% of respondents, by taking into account the penetration rates in the three countries).

Regarding the market data in 2005, their sales represent only 31% of the sales of air condenser technologies in Europe (Table 37 and Table 38), this being close to the consumer survey results (45% of respondents for air vented technology and 14% for washer-dryers).

Table 37: Sales by air technologies, in units

Technology	Western Europe		Eastern Europe	
	Sales Units		Sales Units	
	2002	2005	2004	2005
VENTED	1 724 414	1 651 208	9 968	9 306
CONDENSER	1 632 564	2 017 068	18 234	28 933
UNKNOWN	NA	57	1 233	180
Total	3 356 978	3 668 333	29 435	38 419

Source: GfK

Table 38: Sales of washing-drying machines in Europe, in units

Washing-Drying Machines	Sales Units			
	2002	2003	2004	2005
Western Europe	549 933	550 163	587 161	583 452
Eastern Europe	25 007	44 132	40 684	52 318
Total	574 940	594 295	627 844	635 769

Source: GfK

Remark: The average share of washer-dryers is due to its greater penetration rate in Eastern Europe (confirmed by the use rate in Poland: 59%, as shown in Figure 30) while its use is less widespread in Western Europe (18% in the UK and 7% in France). Based on the GfK data, the market shares are rather higher in Western Europe but GfK Figures indicate an 11% growth since 2002, with +6% for Western Europe and +109% for Eastern Europe.

However, according to information provided by CECED, the number of washer- dryers in Eastern countries such Poland is now decreasing.

Capacity of dryers

Most respondents' dryers (57%) have a capacity of four to six kilograms (Figure 33).

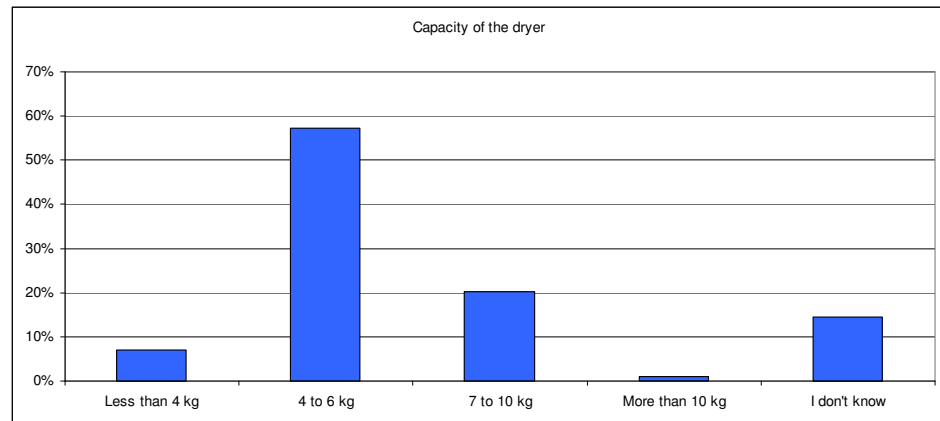

Figure 33 Capacity of the dryer (weighted results)

This confirms market data since, in 2005, 84% of sales in Western Europe and 92% in Eastern Europe concern the load capacity between 4,5 and 6 kg (as seen in Task 2 ; source GfK).

When weighing the results for the different load ranges with minimum / average / maximum factors, the range of possible capacity is between 4.5kg (bottom margin range) and 6.9kg (top margin range) and the average capacity of a dryer is 5.7 kg (middle range). This is to be questioned due to three aspects:

First, the capacity of the dryer is a value difficult to estimate for the end user if he or she doesn't know the exact value in the first place.

Second, the weighing factors for the capacity ranges are arbitrary and cannot be used to accurately evaluate the capacity.

Third, the share of people who do not know the capacity of their dryer is higher than the number of dryers rated less than 4 kg, thus representing a large quantity of uncertainty.

The CECED model database for 2006 gives an average of 5.96 kg for tumble dryers' capacities. It should be noted that the differences might be due to the age of the appliances. In fact, most of the dryers of the consumers surveyed were bought before 2006, when capacities were generally lower on the market.

Type of control

The end of the programme of a laundry dryer can be controlled by:

- Time: "Time controlled" means that the duration of the drying program is manually selected by the consumer when choosing the program (duration linked to the type of program) or directly selected using a "time" button. The laundry dryer is known as being "not automatic".
- Moisture: "Moisture controlled" means that the end of the drying program is automatic and linked to the level of moisture in the laundry (either directly or indirectly).

The average capacity of dryers is 5.7 kg according to the consumer survey, against 5,96 kg according to the CECED model database in 2006

76% of laundry dryers are declared to be time-controlled but this is not consistent with current market trends

The survey shows that, overall, three quarters of all laundry dryers are time-controlled Figure 34.

The results per country are shown in Figure 35 for comparison purposes. These results are, however, to be questioned because it is assumed that many end users don't exactly know the type of runtime control and guessed the answer instead of choosing "I don't know",

The large proportion of time-controlled dryers in the UK may skew the results. This is not coherent with recent markets trends

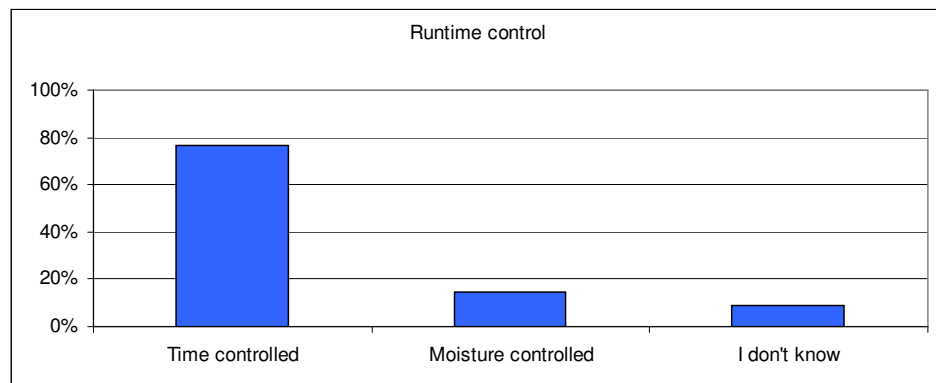

Figure 34: Run time control (weighted results)

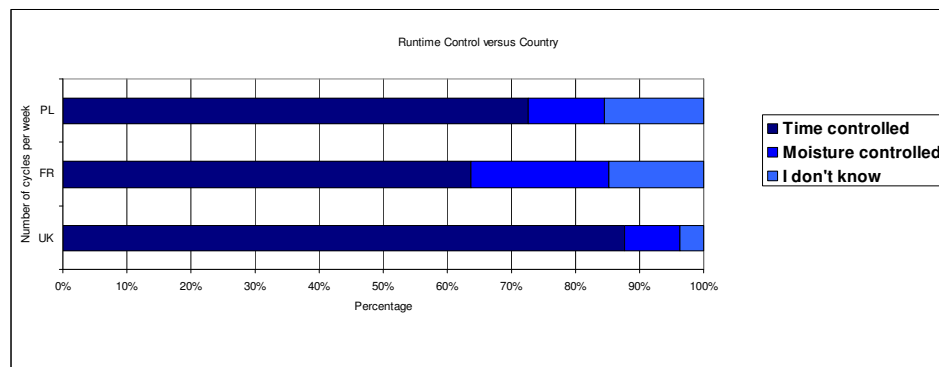

Figure 35: Runtime control by country

It is commonly assumed that people tend to overestimate the drying time needed thus leading to an overconsumption of energy.

Moisture control, on the contrary, automatically determines the appropriate duration of the drying process, adapted to the type of laundry and required final moisture level. It should be noted that the majority of modern dryers feature a moisture controlled runtime option, especially when they are of the condenser type.

Energy efficiency class of dryers

The energy efficiency classes of tumble dryers are defined in the European Directive 1995/13/EC on the mandatory energy labelling of this type of household appliances, for both electric vented and condenser tumble dryers.

According to the results of this survey, there is a large number of people who do not know the energy class of their dryer (47 %), as shown in Figure 36. This share seems to indicate a lack of interest of consumers about the energy performance of their dryers and

47 % of consumers surveyed do not know the energy class of their dryer

possibly a lack of information on the potential reduction of energy consumption they could enjoy when buying more efficient appliances.

The remarkably large number of A/B class appliances can be challenged.

The results indicate a remarkably large ratio of people owning a class A (20 %) or B (21 %). However, this can be challenged. Indeed, according to the 2006 CECED model database, the most widespread class currently on the market is class C. The market share according the energy efficiency classes are as follows:

- A: 1,4%
- B: 15,5%
- C: 80%
- D: 2,6%
- E: 0,4%

Manufacturers confirm that the current most widespread classes on the market for tumble dryers are rather class C.

Some consumers may confuse the energy class of their dryers with that of their washing machines (which are rated A on average).

Another explanation may lie in the fact that people who buy an A or B-rated appliance know what they bought because it is important for them, contrary to the 47% who do not remember whose large share further supports this assumption.

Alternatively, the issue could be explained by a high percentage of households which don't know the energy efficiency class of their dryer but overestimate it, thinking "A" might be the "right" answer.

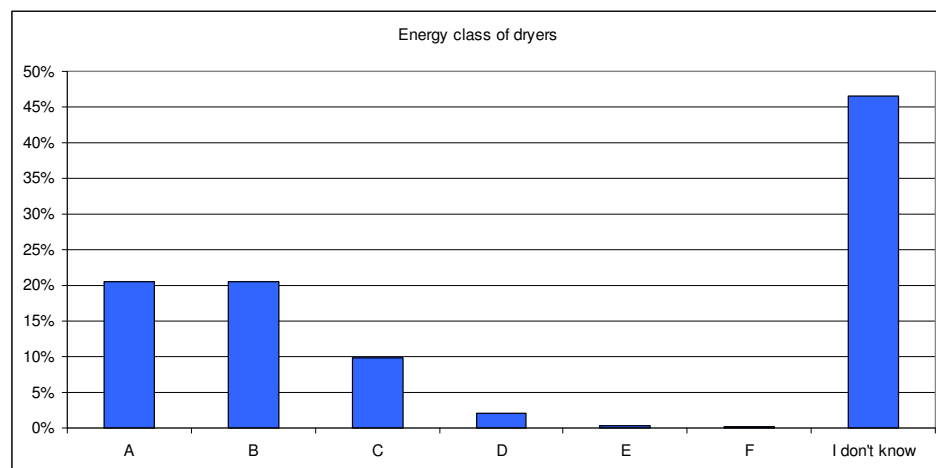

Figure 36: Energy class of dryers (weighted result)

According to a manufacturer, the sale and use of certain classes of tumble dryers can greatly depend upon the availability of power supply. For example in Italy, one model of A class dryer has a very high penetration rate. This is probably due to the energy rate per household in Italy being linked to the maximum available power. At the lowest rate, the maximum allowable power is 3 kW, and one could thus argue in favour of highly efficient dryers being more widespread in Italy.

The most widespread range of purchase price is 200-399€

Purchase price

Most respondents (40%) spent 200-399 € on their dryers. 22% of the respondents do not know how much they spent, making those that spent less than 200 € come third with 19 % of respondents (Figure 37).

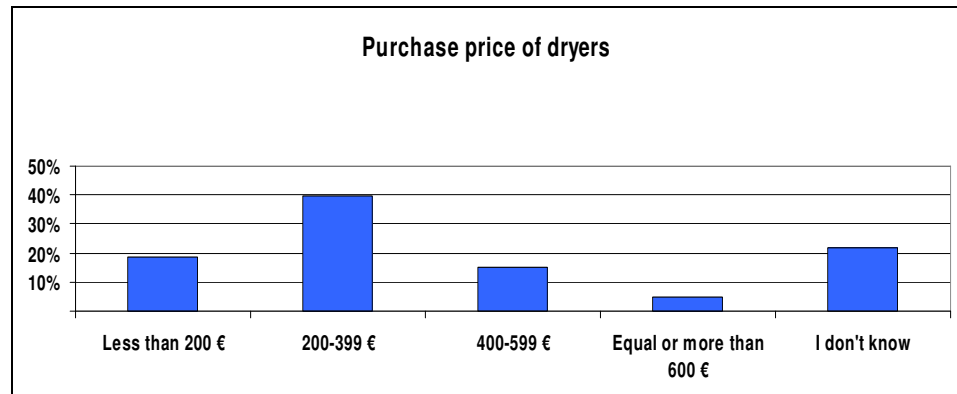

Figure 37: Purchase price of dryer

Regarding the price of several types of laundry dryers, the distribution complies with the price of air vented tumble dryers (around 300€), the most widespread type of laundry dryers in the countries studied. The estimated price of air condenser tumble dryers is closer to 460 €, which comes third, as can be seen in Figure 37.

More than 21% percent of the respondents do not remember the price of their laundry dryer. Once the laundry dryer is bought, the sales price is not important anymore. This seems to be consistent with how home appliances are perceived by consumers: most of them only expect them to perform their function without causing problems (see Lot 14).

Age of dryers

Unnecessary energy consumption in households is often found to be influenced by overaged appliances.

The average age of dryers is 4.8 years

Figure 38 indicates that most respondents have dryers less than three years old (37%) or three to five years old (34%); more than 71% of the dryers are thus less than 5 years old. 12% are over 10 years old²⁷. The detailed data allow to calculate an average age of a dryer of 4.8 years (middle range).

Judging from the detailed results, the age of the dryer correlates with the age of the owner: 80% of the people aged 18-29 own dryers which are less than five years old, whereas in the group 60-69, the share is only 62%.

²⁷ Since manufacturers estimate the dryer lifetime to be 13 years (cf. an average duration between 10 and 19 years is a minimum requirement of manufacturing), these 12% of the dryers currently in use are close to reaching the end of their lifetime.

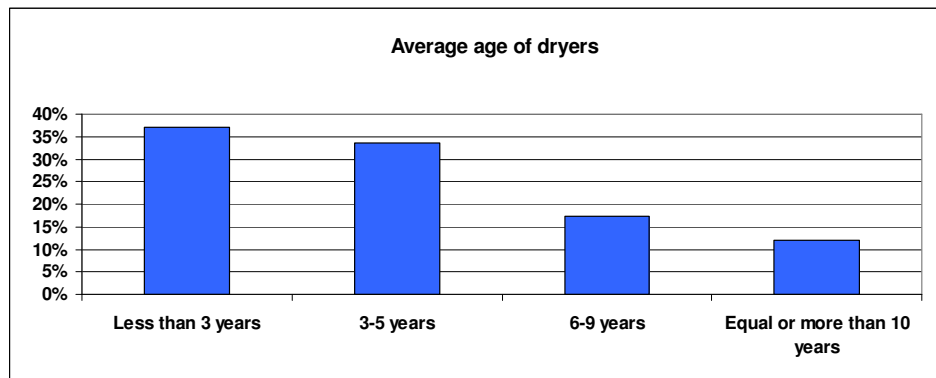

Figure 38: Age of dryers (weighted results)

Length of a dryer cycle

Regarding the average length of a dryer cycle, the Figure 39 indicates a most widespread length of 30-59 minutes for 41% of all respondents, 60-89 minutes coming at second (22% of all respondents).

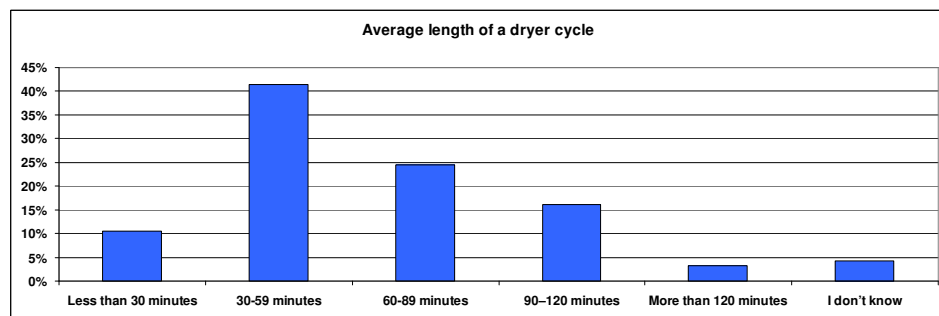

Figure 39: Length of a dryer cycle (weighted results)

The average length of cycles is 59.6 minutes

When weighing the results for the different lengths of a dryer cycle with minimum / average / maximum factors, the range of possible length is between 47.4 minutes (bottom margin range) and 74.2 minutes (top margin range) and the calculated average length of a dryer cycle is 59.6 minutes.

In Figure 40 the detailed results are depicted. Note that due to the small number of respondents with large average loads, the results for "9-10 kg" and "More than 10 kg" are not considered reliable. However, as a general trend, for higher average loads ("Less than three" to "6-8 kg"), the drying time is seen to increase.

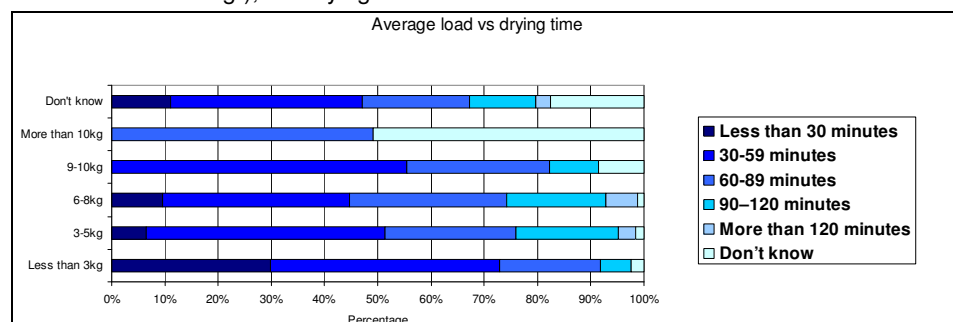

Figure 40: Average load by drying time (weighted results)

III.3 Declared consumer behaviour

III.3.1 Drying habits

In summer

The principal answer to “How do you dry your laundry in summer” is: “outside on the clothes line” (69 % “always” or “often”). Drying “in a tumble dryer” comes second with 24 %, as shown in Figure 41.

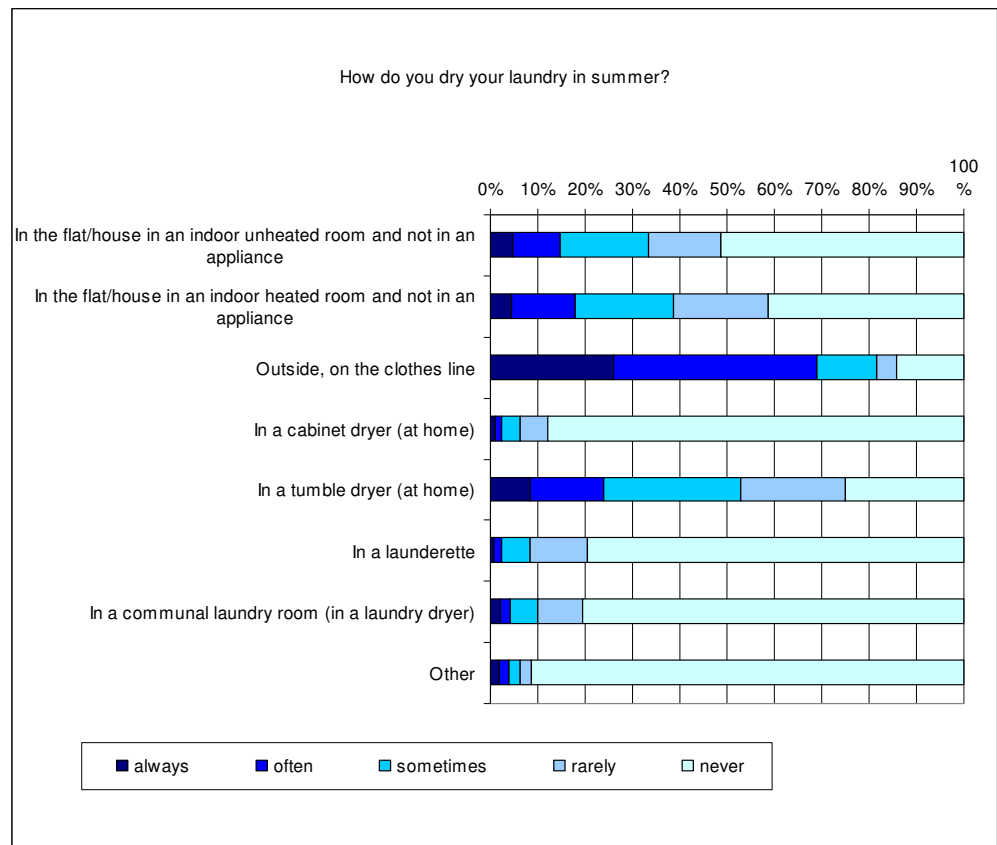

Figure 41: Drying laundry in summer

For each country, the proportions of responses are the following ones, as shown in Figure 42.

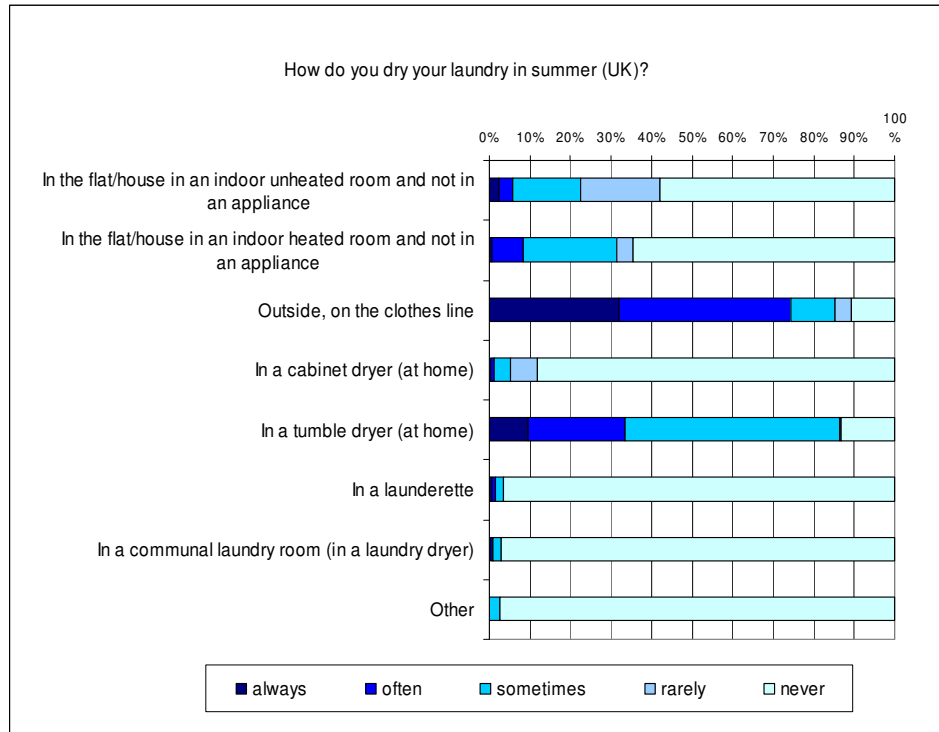

Figure 42: Drying laundry in summer (UK)

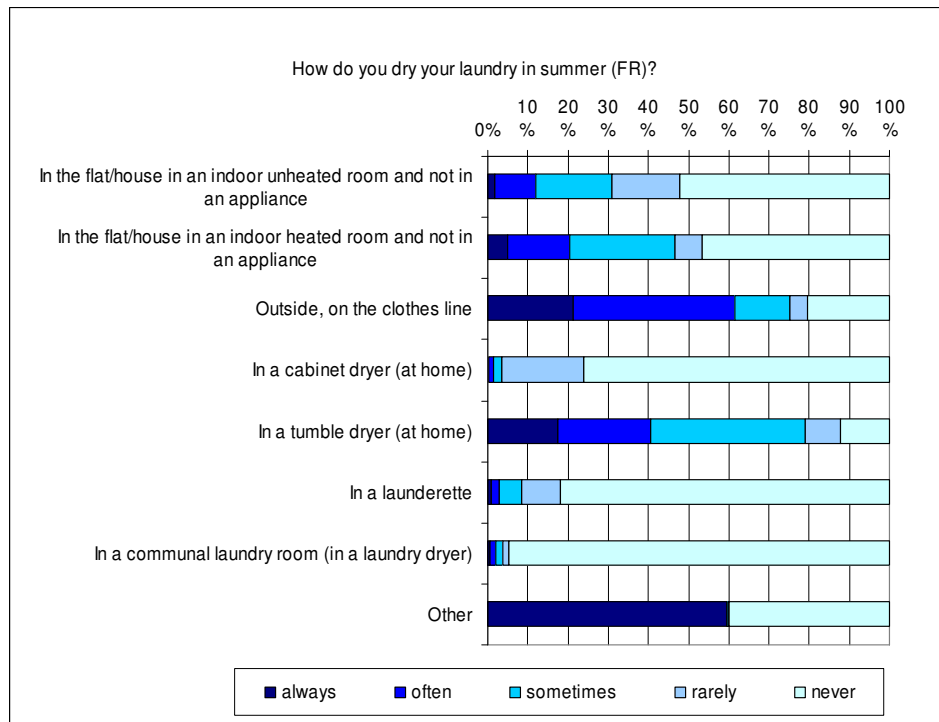

Figure 43: Drying laundry in summer (FR)

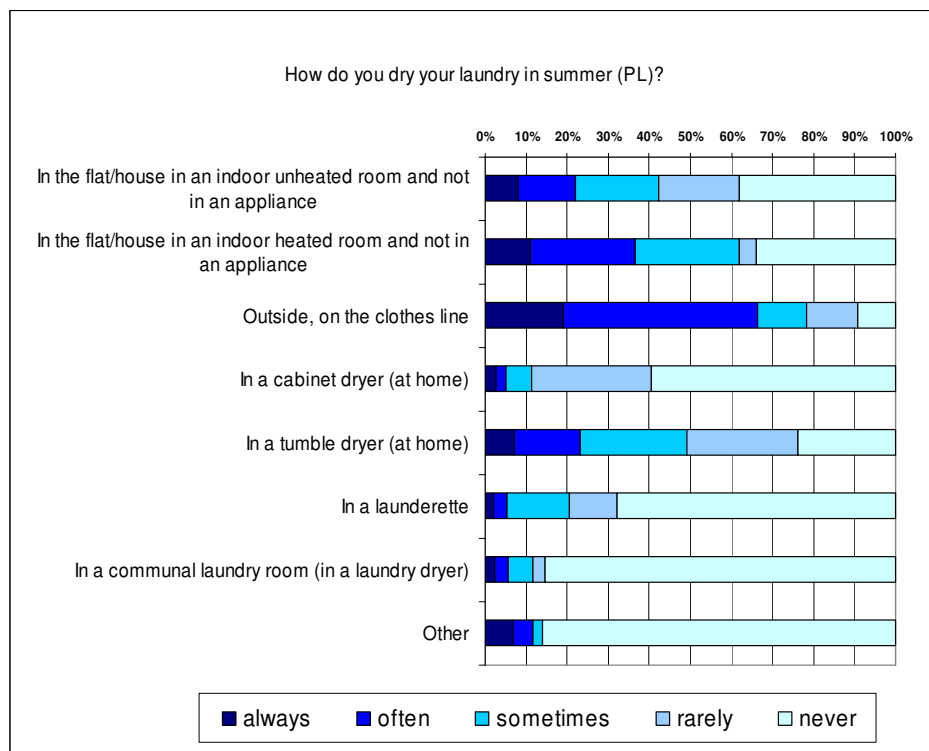

Figure 44: Drying laundry in summer (PL)

The answers can be considered as similar between the three countries, particularly for people drying their laundry “outside on the clothes line” with 74 % of answers “always” or “often” in the UK, 62% in France and 66% in Poland.

A detailed analysis of the differences of habits according to the geographical distribution of consumers in each country (North / Middle / South) reveals few changes apart in France as explained later.

For the situation where a tumble dryer is used at home, the answers “always” or “often” represent 33% of respondents in the UK, 40% in France and 23% in Poland.

The laundry is “always” or “often” dried “in the flat/house in an indoor heated room and not in an appliance”, in 9% of the cases in the UK, 20% in France and 38% in Poland.

These Figures probably indicate differences in habits and living situations. Particularly in Poland, it seems that more people dry their laundry indoor in heated rooms (bathroom, bedroom, for example) than in the two other countries: they may use dryers less often due to economical reasons and may dry their laundry indoor (in heated rooms) even in summer because of living in flats (i.e. not having garden space to hang a clothes line).

Regarding the influence of the climate, the results generally show little difference between the countries (particularly for outdoor drying): that could be due to quite similar climate conditions in summer.

Regarding the French and Polish answers in details, it nevertheless appears that:

- In summer in France, the results for the North (N), Middle (M) and South (S) are very similar, with the exception of a larger share of people drying their laundry outside on the clothes line in the South (72% in the South against 55% in the North). This can be certainly explained with the local climate (higher temperatures in comparison to the rest of the country).
- In summer in Poland, there is a very evenly distributed numbers in all three regions (North, Middle, South) and the regional differences are much less pronounced in comparison with France.

In winter

When drying laundry in winter (Figure 45), 50% of the respondents “always” or at least “often” resort to tumble dryers. Heated indoor rooms (37 %) come second.

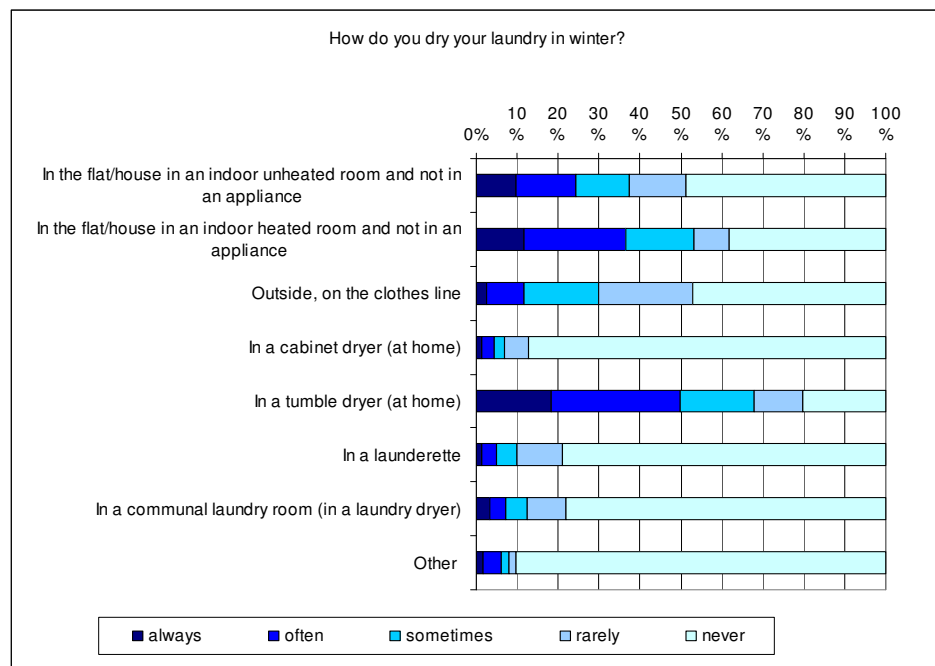

Figure 45: Drying laundry in winter

Per country the proportions of responses “always” and “often” are the following ones, for the most represented situations, as shown in the following Figure s:

- Drying in tumble dryers: 66% (UK), 65% (FR), 38% (PL)
- Drying indoor in a heated room: 30% (UK), 10% (FR), 71% (PL)
- Drying indoor in an unheated room: 5% (UK), 50% (FR), 15% (PL)

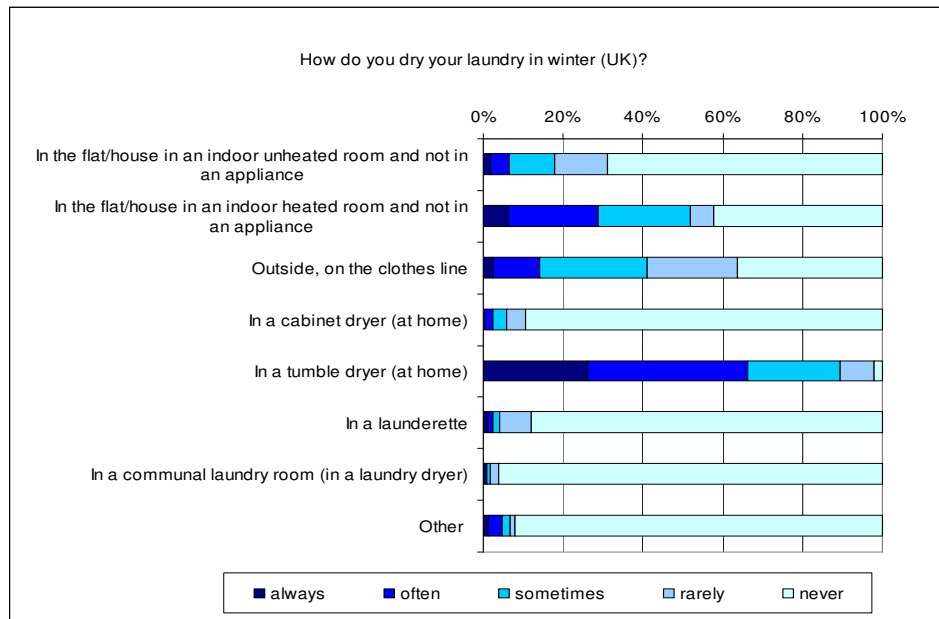

Figure 46: Drying laundry in winter (UK)

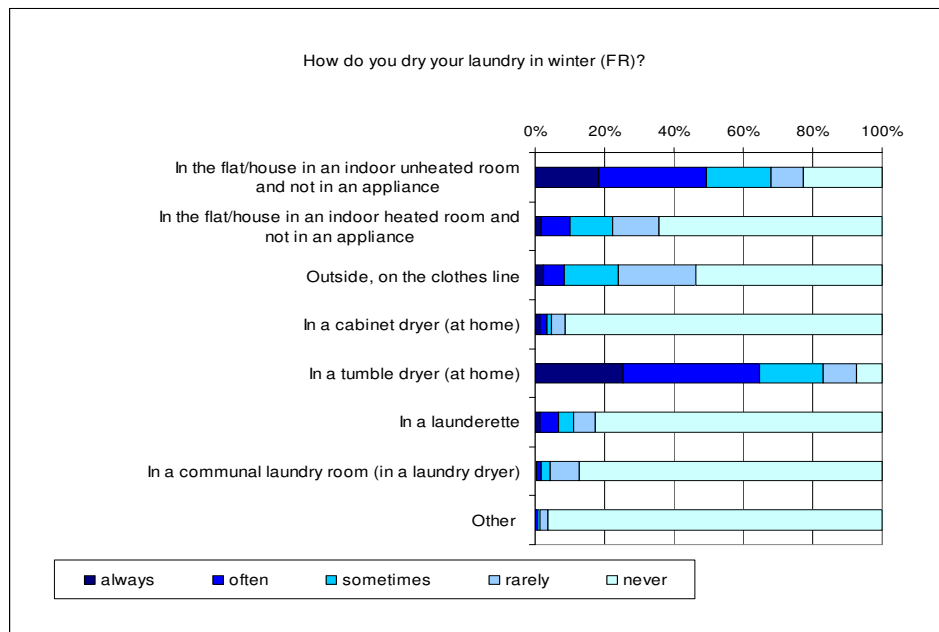

Figure 47: Drying laundry in winter (FR)

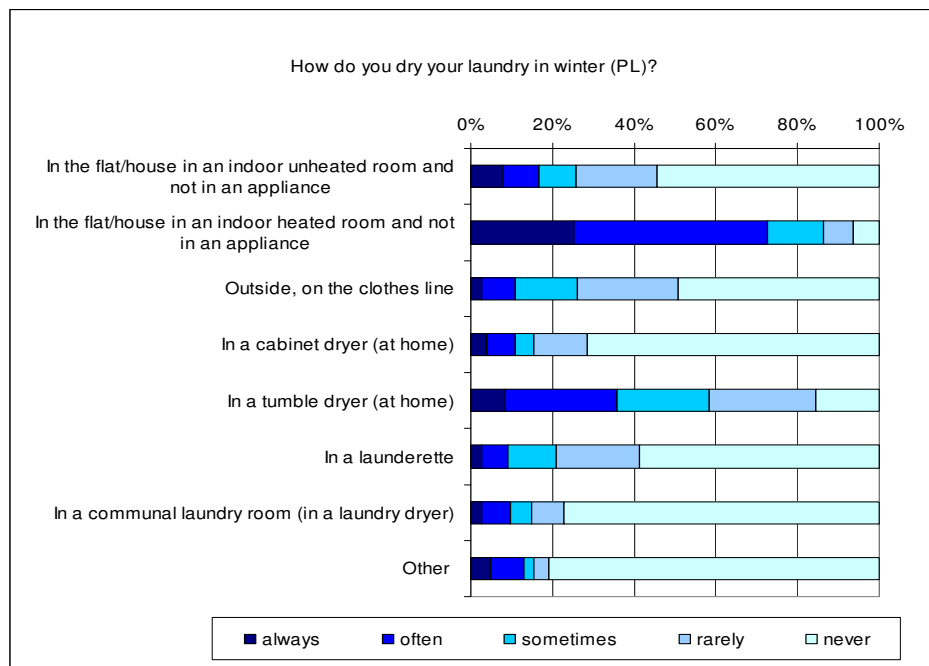

Figure 48: Drying laundry in winter (PL)

These Figure s reveal that in the UK, people prefer using laundry dryers and heated rooms come second; while in France the answers are shared between laundry dryers and unheated rooms (in house: garage, cellar) and in Poland between heated rooms and laundry dryers.

It is likely that, like in summer, the main difference of drying behaviours between Poland and the other countries come from economical/space reasons and result in lesser use of laundry dryers.

Regarding the climate influence in winter, the differences between the countries and even the national regions (N, M, S) are less distinct than in summer. It can be concluded that the drying habits mostly result from the living and financial situations of households.

III.3.2 Frequency of use

The number of cycles per week determinates the degree of usage of a laundry dryer and the amount of its energy consumption considering the energy class of the dryer and its energy consumption per cycle.

Because of the important influence of the climate on laundry dryer use and consumer behaviour, both climate conditions were considered:

In summer

The analysis indicates, as shown Figure 49, most respondents (44%) use their dryer for one cycle per week (whether they live in the UK, in France or in Poland).

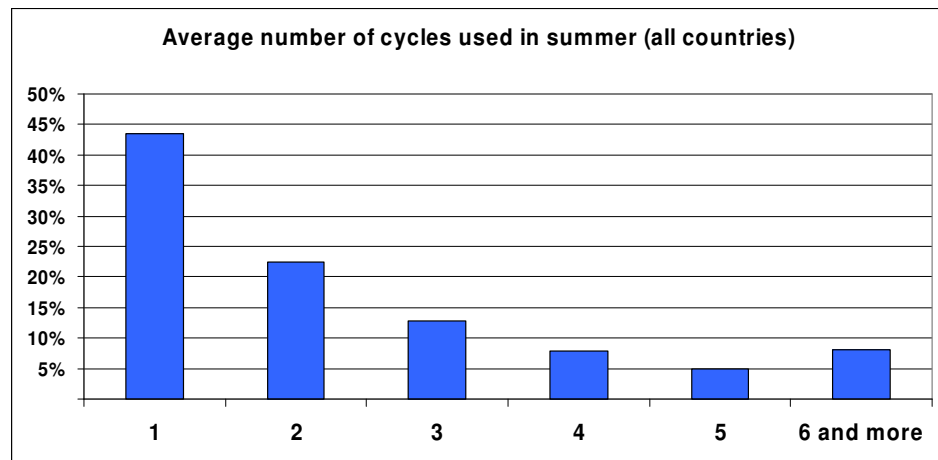

Figure 49: Number of cycles per week used in summer

The average number of cycles per week and household in summer is 2.3

From this diagram, the average number of cycles per week and per household, in summer can be calculated and is 2,3.

By analysing the number of cycles per week against the number of household members (Figure 50), it appears that for “an average household” (between 2 and 4 people), the number of cycles varies mostly from 1 (for 2 persons) to 2 (for 4 persons).

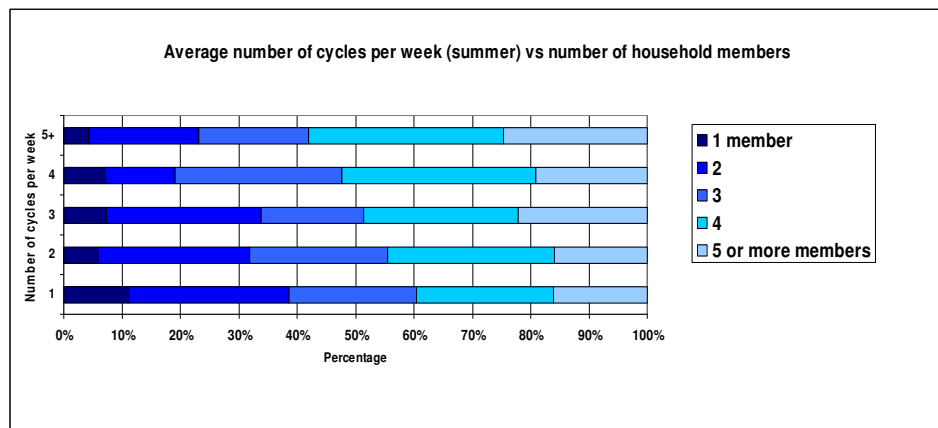

Figure 50: Number of cycle per week (summer) by number of household members

The average number of cycles per week and person in summer is 0.7

Taking into account the real calculated average number of household members, i.e. 3,2 (cf.III.2.1), the following result can be obtained and is 0.7.

In winter

The same analysis in winter (Figure 51) reveals, as could be expected, that the frequency of use greatly increases. 26% of all respondents use their dryers for 6 and more cycles per week (36% in UK, 24% in France and 14% in Poland).

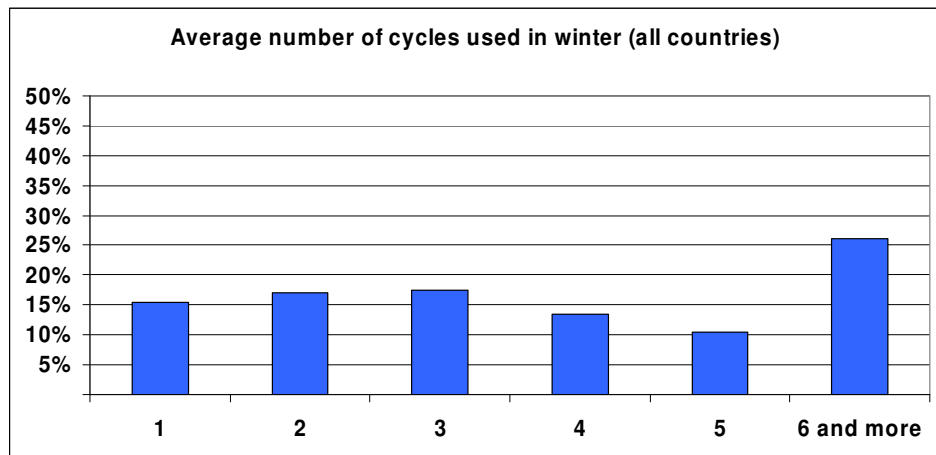

Figure 51: Number of cycles per week used in winter

The average number of cycles per week and household in winter is 3,6

From this diagram, it can be calculated the average number of cycles per week and per household in winter: it is 3,6

The following graph (Figure 52) indicates the number of cycles per week as a function of the number of household members. In winter “an average household” (between 2 and 4 people), use mostly from 2 cycles (for 2 persons) to 4 cycles (for 4 persons).

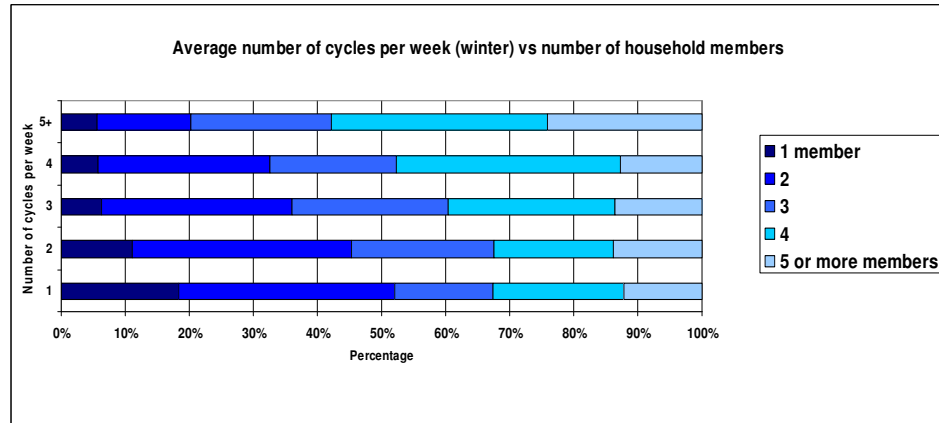

Figure 52: Number of cycle per week (winter) by number of household members

The average number of cycles per week and per person in winter is 1,1

Taking into account the real calculated average number of household members, i.e. 3,2 (cf. 3.1 on the living conditions), the following result can be obtained and is 1,1.

III.3.3 Choice of program

Washing machine spin speed

The average used washing machine spin speeds is 1217 rpm

The energy demand of a laundry dryer can be linked to the spin efficiency of the washing machine. A higher spin speed and an improved spin efficiency (resulting in an improved water extraction from the washing load) reduce the drying time and the energy required by tumble dryers.

According to the distribution of the mostly used washing spin speeds, as shown in Figure 53, it appears that the range “1000-1150 rpm” (rpm: rotations per minute) is the major chosen spin speed with 25 % of answers “always” and “often”, the range “1600-1800 rpm” coming at second with 22 % of answers.

The lower spin speeds (below 1000 rpm) are less represented. One possible explanation is that a large number of more modern washing machines is being used these days, owing – as explained in detail under “Age of dryers” on page 134 – to the proportionally large share of young(er) survey respondents.

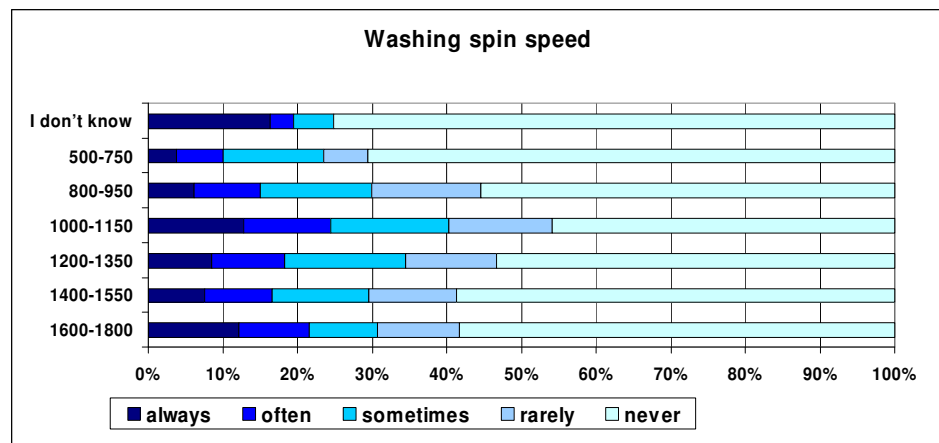

Figure 53: Washing spin speed (rpm) used before drying

According to the detailed data, the average used washing machine spin speed is: 1216.75 rpm (=1217 rpm).

This could be challenged due to the chosen ranges of spin speeds and the rate of people who do not know the spin speed of their washing machine (around 20% as seen on the first line of the above diagram, with the answers “always” and “often”).

In lot 14 (on domestic washing machines), the average spin speeds taken into account for the base-cases is 1129 rpm.

According to these Figure s, it can be concluded that current habits (as expressed in the consumer survey) correlated with higher spin speeds proposed in the new washing machines, point to a reduction in the energy consumption of laundry dryers in the future (if all other things remain equal (e.g. the size of the machine, etc.).

Drying programme

Among the consumers interviewed, the most commonly selected drying programmes are as follows:

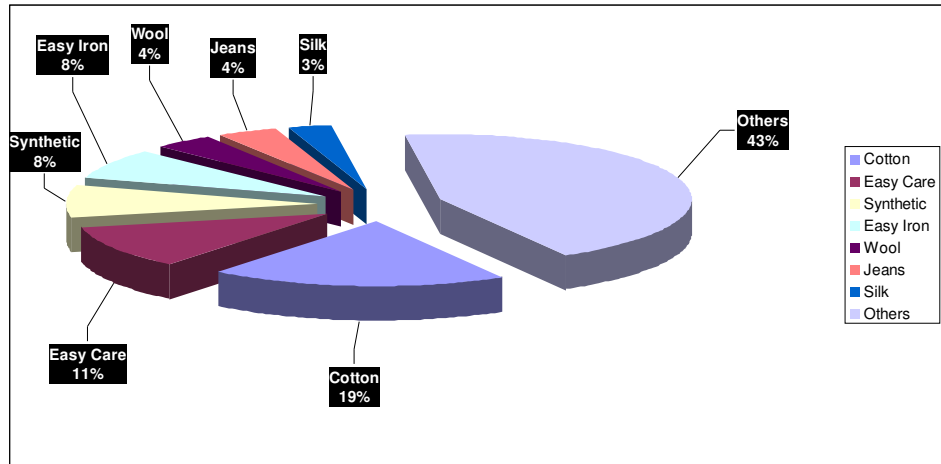

Figure 54: Distribution of the most selected drying programs

The main share for “others” (43%) comes from a large number of types of programs proposed by the interviewed consumers (particularly in Poland). The programs displayed in Figure 54 are those “always” or “often” chosen by people. It comes that “cotton” and “easy care” can be considered among the most commonly chosen programs. Nevertheless the Figure s can be challenged due the high rate of “others”.

The most widespread selected drying programme is “cotton”

The Figure s can be correlated to the following data coming from a manufacturer (consumer study carried out by an external company), where the most selected program is “cotton” (Figure 55).

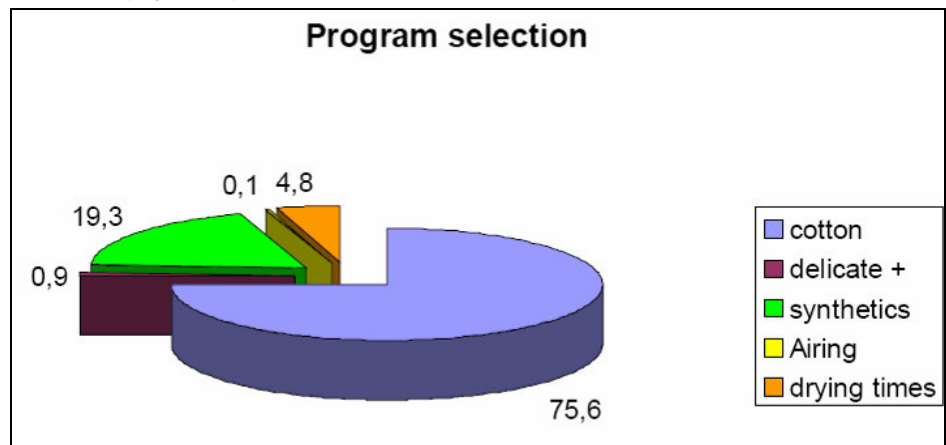

Figure 55: Distribution of common used dry programs (special study)

Source: Confidential study

"Reduced iron" programme

According to the manufacturer survey, less than 40% of the laundry dryers have a programme made to reduce ironing after drying process.

Some manufacturers have been developing a low consumption mode to reduce the ironing stage: the tumble has to stay in action in order to prevent any squeezing of the laundry.

According to a manufacturer, this feature does not depend on the type of dryers and consumes a little amount of energy (200Wh).

As a result, for a low power consumption, reduced iron option allows a reduction of the whole laundry care power consumption.

III.3.4 Load and loading habits

Load

It has been previously shown that the most represented dryer capacity is in the range from 4 to 6 kg. According to the EN 61121 standard, the tested load should be the same as the dryer capacity (i.e. the drum volume). In real life, however, the loading (kg of laundry) is most of the time smaller.

As shown in Figure 56, the most common loading is 3-5 kg (for 50% of all respondents).

These Figure s represent an average load for all countries. By looking in details at the national habits, the ratio is almost the same in the UK, France and Poland. It can be noticed that the "3-5kg" loading represents a major share in France (76 to 78%).

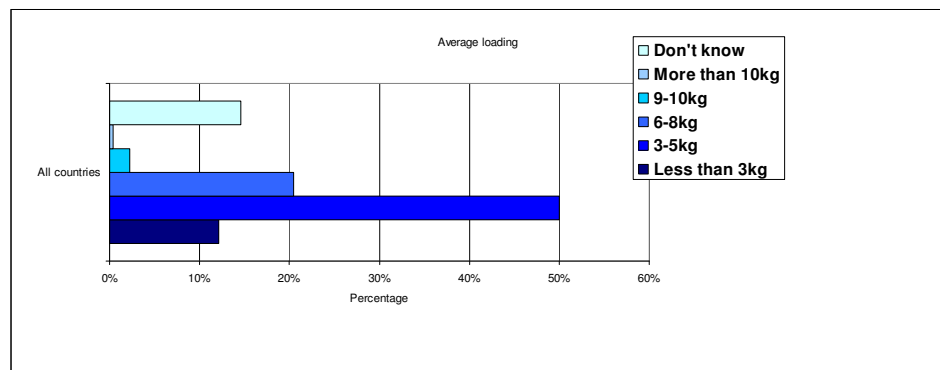

Figure 56: Average loading (kg) (weighted results)

The average loading for tumble dryers is 4,5 kg

According to the detailed data, the range of possible loading is between 3.5kg (bottom margin range) and 5.6kg (top margin range) and the average loading for tumble dryers is 4.5 kg (middle range). This is likely to be overestimated due to the difficulty of estimating this data and the possible confusion with the dryer theoretical capacity.

It must be reiterated that the values are estimated by the respondents, so the accuracy of the values is highly questionable. Following a literature review and exchanges with manufacturers, and to ensure consistency across the laundry care chain, it was decided that the value defined in Lot 14, which is 3.4 kg, should be considered for the base case.

Loading habits

Regarding the Figure s about the average dryer load versus the dryer capacity, it comes that in most cases, people use their laundry dryer at its optimal capacity, or at least claim to. Again, the problem lies in the fact that the Figure s are end-users estimates. The results on the habits of consumers when loading their dryer are displayed in the following diagram:

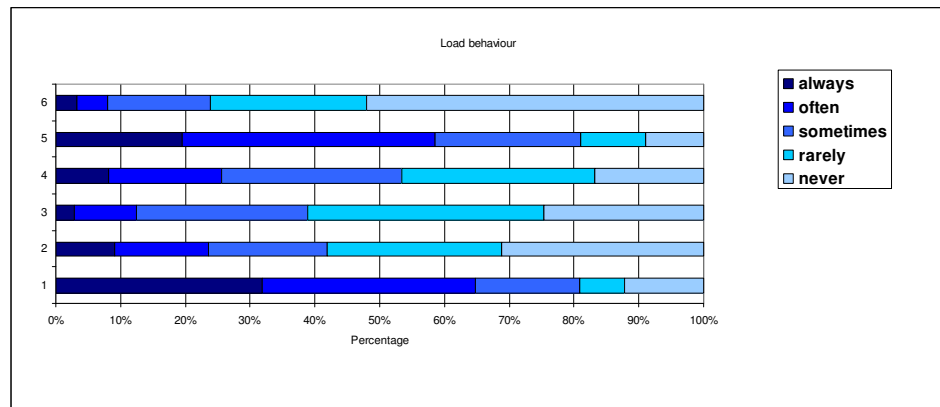

Figure 57: Loading behaviour of consumers (weighted result)

For the proposed cases:

1	How I load the machine depends on the kind of laundry
2	I run the drying machine regardless of how much of its capacity is used
3	I run the machine even with a relatively small amount of laundry inside
4	I do not usually fill the machine completely
5	I use the machine's full capacity without overloading it
6	I load the machine in such a way that it is almost overloaded

Regarding the situations, the most represented ones are “How I load the machine depends on the kind of laundry” (67% of the respondents for the vented technology and 56% for the condenser technology). The situation which comes second (respectively 62% and 58%) is “I use the machine’s full capacity without overloading it” (which is consistent with a 3.4 kg load for a 6kg capacity machine, according to manufacturers).

III.3.5 Attitude towards dryer options

The trend is towards an increase in the number of functionalities proposed to consumers. This should help the consumer adapt the dryer (drum rotation, etc) to fabrics (anti crease option for laundry care), choose to delay the beginning of the drying program (start time option), make the next step of ironing easier (reduced iron option), etc.

Theses features can be important in the power consumption of the device

Among the different kinds of functionalities, the results of a survey (consumer study carried out by an external company for a manufacturer), reveal the ratio of the major options used by consumers. According to the following Figure , the anti crease option in the first chosen while start delay is the last one (20% of respondents).

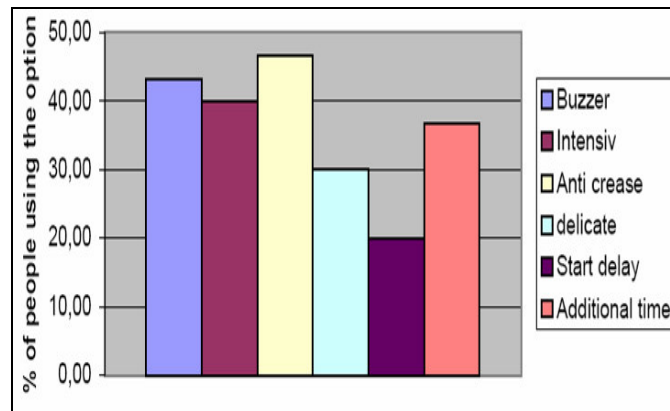

Figure 58: Options most frequently used

Source: confidential study

Start and end of programme

Power switch

Most of the laundry dryers are equipped with a power switch (67% of them)

Figure 59 reveals that around 67% of consumers declare their laundry dryers as being equipped of a power switch. Since the questionnaire did not ask for *start* switches (these are featured in dryers that power off automatically after they have finished drying) in particular, the results are possibly skewed.

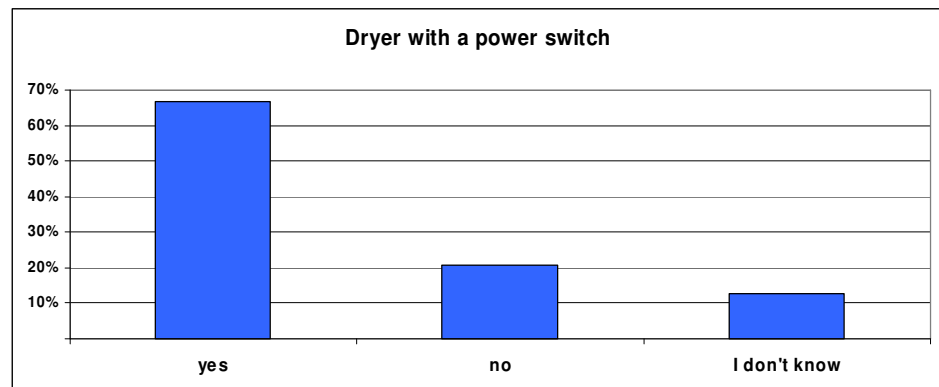

Figure 59: Ratio of dryers with a power switch

For more than 75 % of them “always”, or at least, “often”, use it (Figure 60).

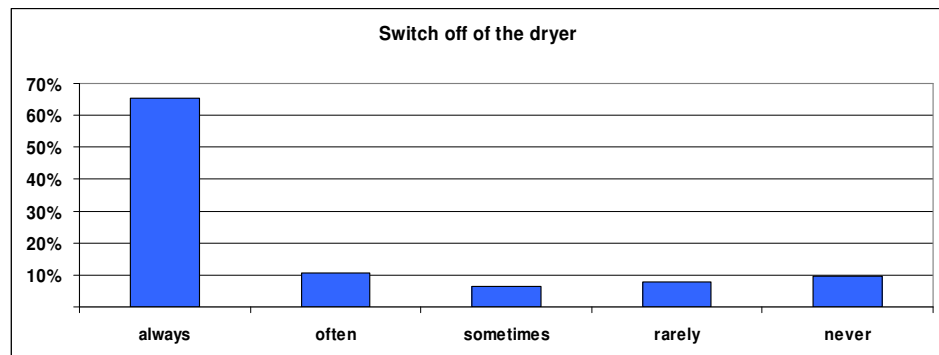

Figure 60: Use of the switch off button of the dryer by the consumer

The use of this power switch avoids all energy losses due to the “On Button” Mode (see next section on the “start time option”).

Start time option

The start delay option is often used for money savings, (to benefit of off-peaks fare from the power supplier) and for time savings.

According to the surveyed manufacturers, 50% of the laundry dryers on the market may have a start delay option (mostly used in France), but according to the MTP²⁸, delay timers are not particularly common. They estimate that only 5% of the 36 tumble dryers included in their study were equipped with this option (in 2007). In this survey, 20% of the respondents declare using it, which is in-between the two.

When using this option, according to the consumer survey, the delay chosen is estimated less than 3 hours for 43% of people and between 4 and 6 hours for around 32% of respondents. Around 12% of consumers do not know really the exact duration of the start delay.

Consumers who use this option appreciate the advantage of unloading their “hot” laundry as soon as the drying program is finished. As previously said, the advantages are:

- Time savings with reduction of time spent on ironing,
- Money savings with the off-peaks fare overnight.

²⁸ BNXS15: “Standby power consumption – domestic appliances”, MTP, UK, 2007.

A small share of dryers have a delay timer option.

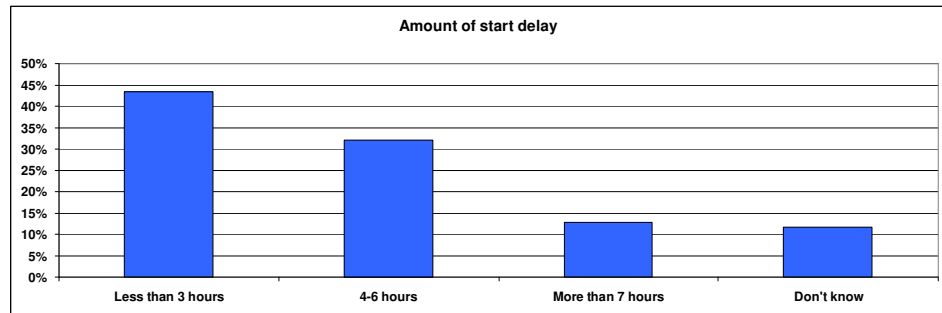

Figure 61: Distribution of the amount of start delay (weighted results)

If used, the average chosen time is 2.5 hours

According to the detailed data, the average amount of start delay is 2.5 hours. This has to be taken into account with caution (delay timers not commonly used as estimated by MTP).

The level of energy consumption was measured in this waiting mode. In the table below, the maximum and minimum Figures are rounded:

Table 39: Extra energy consumption due to some options of the laundry dryer

Tumble dryers (36 appliances measured):

Mode	Max (W)	Min (W)	Average (W)	% of models with consumption
Standby	-	-	-	0%
'On' button engaged	4	1	2.6	38%
Delay timer operated	3	3	2.9	5%

Source: MTP (UK), 2007.

End of programme

At the end of programme, the "on button" remains engaged (when there is a power switch) until the consumer chooses to switch off the dryer. The "on button" mode then represents the status of the appliance at the end of a programme, while waiting for user attention.

According to MTP, a small amount of energy is used during this "on button" state.

Regarding the consumer behaviour, the survey reveals that 37% of interviewed people unload their dryer and turn off the button less than 30 minutes after the end of the programme, while 32% immediately after the end; then 69% estimate that the time until unloading is less than 30 minutes.

Most of the consumers (69%) unload their dryer less than 30 minutes after the cycle has finished

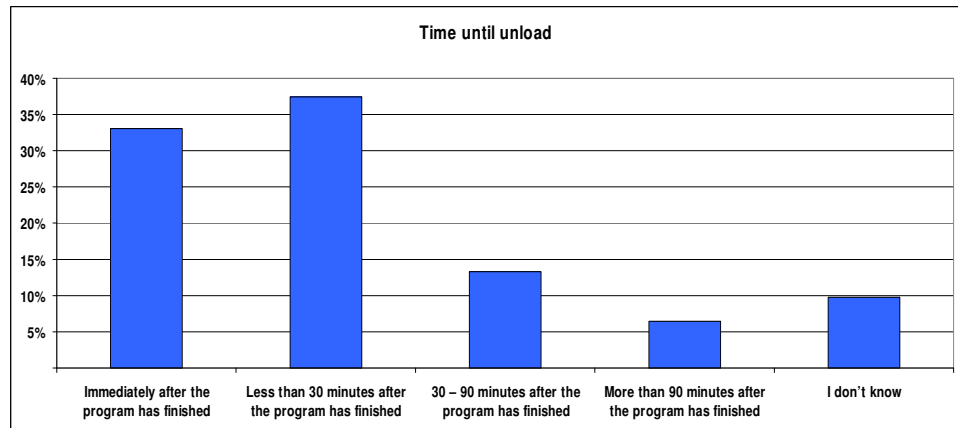

Figure 62: Time until unload the dryer and turn off the button

According to the detailed data, average time between the end of the programme and the unloading of the dryer is 24,6 minutes.

The average time until unloading is 24,6 minutes

Use of consumables

To the question “do you use consumables such as wipes for a sweet perfume?”, 80% of all the respondents answer no (Figure 63). Considering the rate of answers, this can be considered as reliable.

80% of the consumers surveyed do not use consumables during a drying cycle

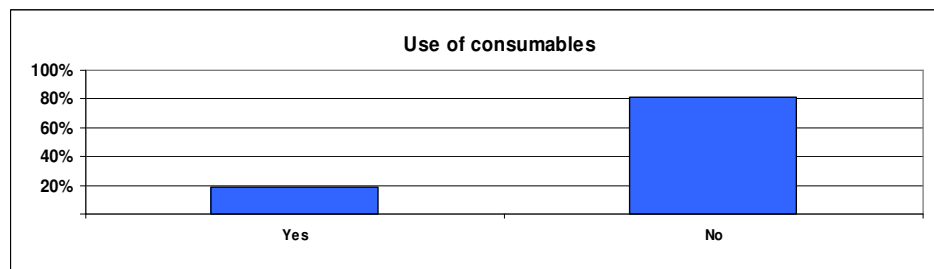

Figure 63: Use of consumables

According to this analysis, it is therefore not relevant to take into account the use of consumables during the drying cycle.

Cleaning of components

The manufacturers explain that the efficiency of dryers (and thus their energy consumption), can depend on the cleaning of some components. This is the reason why some investigations were performed on this issue. However, it was précised that the energy performance is not impacted when the fluff is not cleaned for up to 5-6 runs. On the contrary, the appliance shuts down for security reasons when it is fully clogged and no drying can be performed.

The fluff filter

On product sheets, manufacturers advise to clean the fluff filter following each drying cycle to ensure a better efficiency of the air circulation. According to the consumer survey (Figure 64), around 36% of respondents comply with this recommendation, while 18% clean the filter once a month.

The fluff filter is most of the time cleaned after each drying cycle

Then 64% of respondents do not clean the fluff filter after each drying cycle, with the risk of an increased energy demand due to this behaviour.

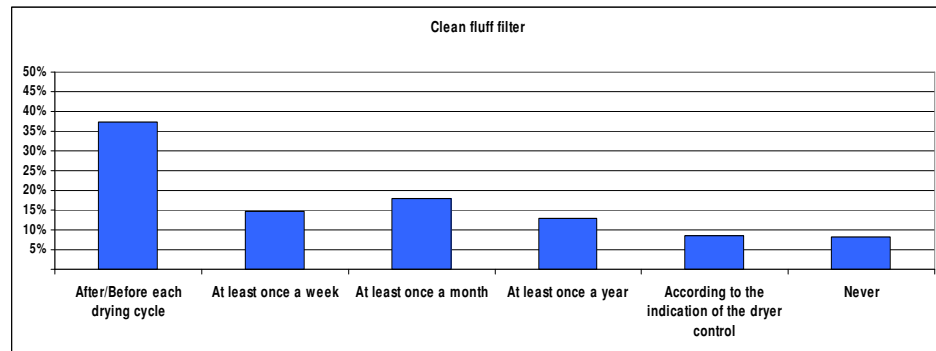

Figure 64: Cleaning of the fluff filter

It should be pointed out that some dryers are equipped with a LED indicating a needed cleaning.

The heat exchanger

80% of consumers clean the heat exchanger at least once a year

Like for the filter, manufacturers advise owners of air condenser tumble dryers to clean their heat exchanger regularly (though not after each drying cycle). According to the consumer survey (Figure 65), around 22% of respondents comply with this recommendation at least once a month, while 20% never do.

With an average of 80 % of people cleaning their heat exchangers at least once a year, people are taking into account the recommendations of manufacturers when it can influence the useful life of their appliances.

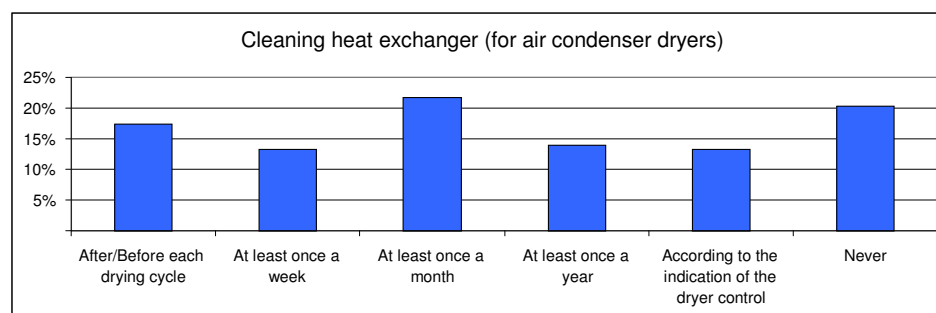

Figure 65: Cleaning of the heat exchanger (in case of air condenser dryer)

III.3.6 After the drying phase: ironing or not?

In the whole laundry care process, the ironing phase normally follows the drying one. The ironing process and the selected ironing program greatly depend upon the type of fabrics (cotton, silk, synthetics, easy care), the selected drying program, the way of wearing clothes (uncreased or not for example), etc.

25% of consumers always iron their laundry after drying, 22% always put it directly away.

According to the consumer survey, 25% of the persons interviewed always iron the dry laundry directly after drying and 22 % put the clothes on straight away (Figure 66). Combining the responses always” and “often” for the situations “iron the laundry” or “put it directly away”, it comes that, 74% of respondents iron their laundry always or often while 62% put it directly away always or often.

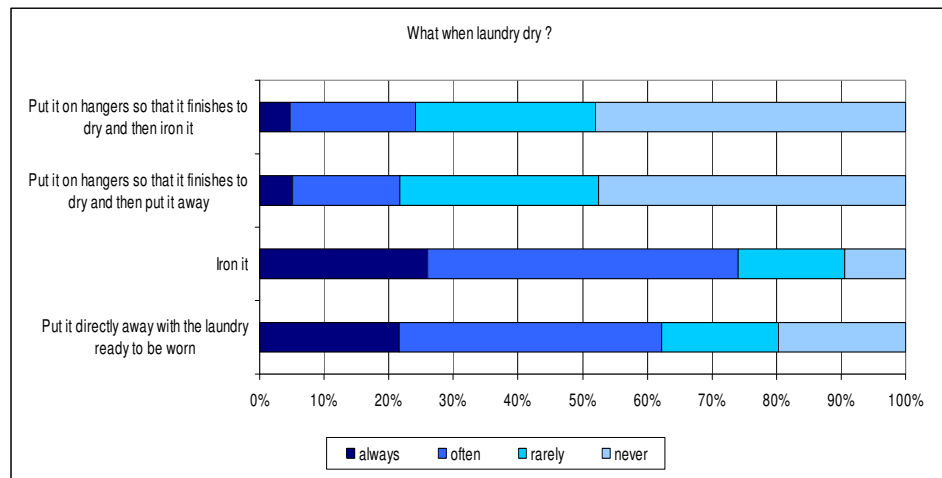

Figure 66: Consumer behaviour with the dry laundry

For people willing to iron their laundry, most of them (40%) use the cotton program which needs a higher heat (with steam) than the other programs (Figure 67).

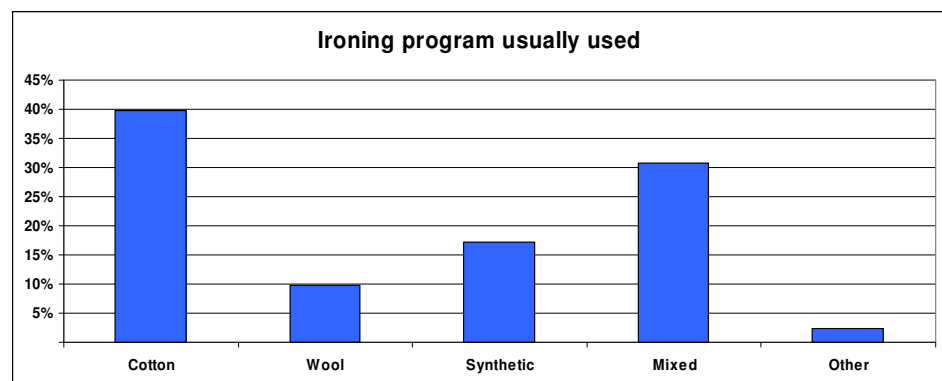

Figure 67: Ironing program usually used

III.3.7 Buying decision

For manufacturers, the purchase price is the most widespread buying parameter on a general aspect

This section deals with the identification of the parameters which can help consumers when choosing which laundry dryer to buy.

In the manufacturers' survey, several aspects were investigated and classified as general and environmental aspects.

Based on some internal and confidential studies carried out by themselves or by external companies, the manufacturers rank the buying decision criteria as shown in Figure 68. The purchase price comes first (considered as playing a decisive role by 83% of interviewed manufacturers), then the technology / performance of the appliance (for 67% of interviewed manufacturers), the brand image and the offer of service both ranking third (33%).

The load capacity and the aesthetic design are considered as a "medium" buying decision criteria by all the manufacturers.

Other parameters seen as having a high importance were added by some manufacturers such as the running costs and the quality.

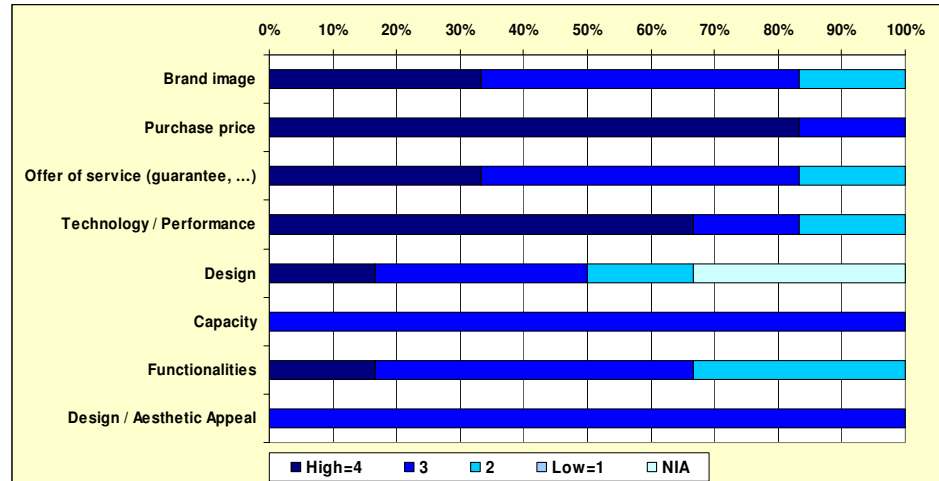

Figure 68: Consumer buying decision criteria on general aspects (according to manufacturers)

NIA = No Information Available

For manufacturers the energy consumption is the most widespread buying parameter on environmental aspects

On environmental aspects (Figure 69) the estimations, for the highest ranking buying decision criterion, are in favour of energy consumption (for 83% of interviewed manufacturers), proven longer life time (33%) and power saving functions (for 17% of answers considered as a high ranking buying decision parameter, 67% of interviewed manufacturers considering it as “medium”).

The criteria “use of recycled materials” and “reuse and recycling options” are at the lowest place: this can be explained by a low level of knowledge of consumers regarding end of life issues, recycling potential, etc.

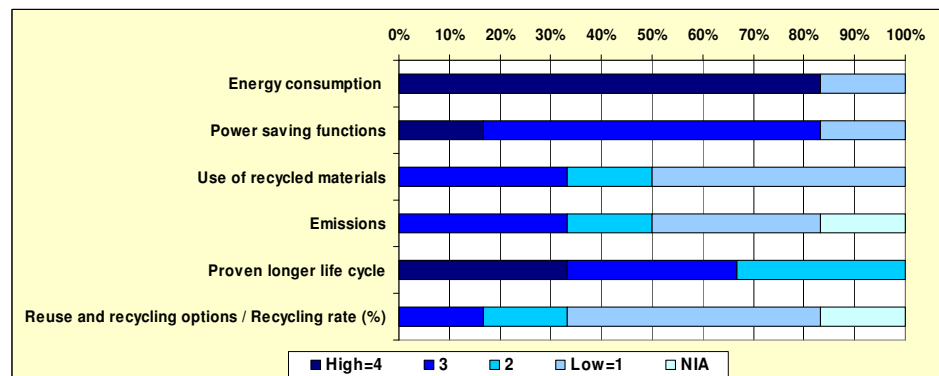

Figure 69: Consumer buying decision criteria on environmental aspects (according to manufacturers)

NIA = No Information Available

To the question “Do you see any relationship between environmental features of products and their market success?”, one of the interviewed manufacturers replied as follows:

“The market is strongly segmented with respect to willingness to pay, for low consumption. From a market research in England, the running cost is in the 9th position

in the reasons for purchase selection and power consumption does not appear explicitly in the list.

From a different market research the “green/energy efficiency” ranks 13th. The first position is occupied by good value for money and the third by the purchase price.”

At the same question the opinion of another manufacturer is: “Retailers are traditionally only interested in price and not in environmental capabilities – the most eco-friendly tumble dryers are not seen to be eco friendly by consumers with a genuine desire to reduce carbon emissions – they are generally bought by people who wish to be seen to be doing their bit and are sold in extremely small numbers.”

The same criteria for buying decision have been investigated in the consumer survey.

For consumers the purchase price and the running costs are the highest ranking buying parameters

Figure 70 shows that the results are overall the same as those from the manufacturer survey: the main aspects taken into account by consumers are the purchase price (60%), the estimated running costs (48%), some environmental aspects and particularly the energy consumption (45%) and a longer lifetime (42%).

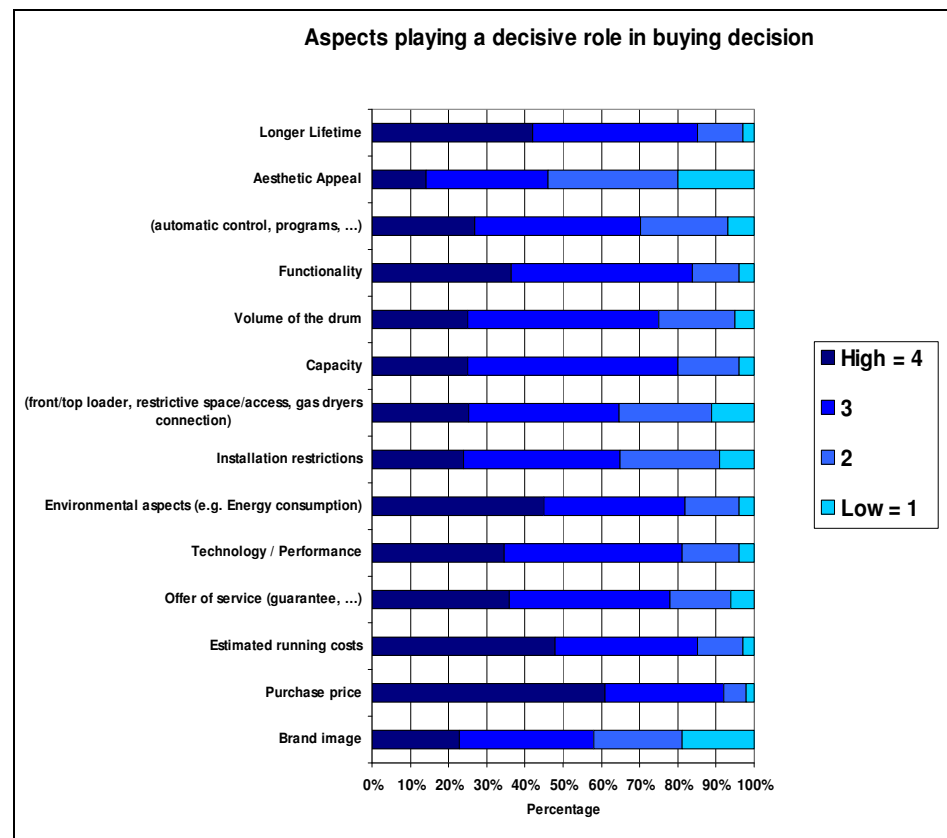

Figure 70: Consumer buying decision criteria on several aspects (according to consumers)

According to one of the surveyed manufacturers: “Most consumers will not pay an extra price for a lower consumption dryer, unless it pays back in 2-3 years.”

On the question of the trade off to make between purchase price and power consumption, the consumers survey confirms this low willingness to pay: it shows that they would consider a payback period of only 1-2 years (for 48% of them).

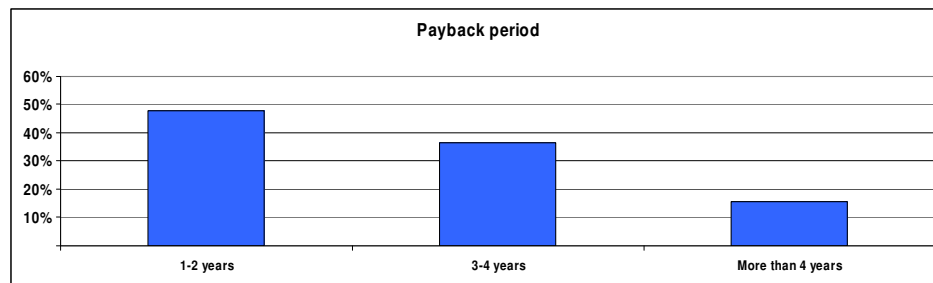

Figure 71: Payback period considered by the consumer for buying decision

This confirms the previous result showing that the purchase price is the key parameter for buying decision and consumers will not pay an extra charge for an appliance with reduced power consumption or better energy efficiency.

III.3.8 Attitude towards energy and environmental issues

Towards energy

According to the consumer survey carried out on washing machines and dishwashers (Lot 14): over 50% of the interviewed people estimate the influence of tumble dryers on the global energy consumption of a household as “great” or even more “massive” (Figure 72) but also more than 25% of consumers do not have an opinion. In addition, consumers rank dryers as the third most energy consuming appliances, after washing machines and cookers / ovens, among the listed products.

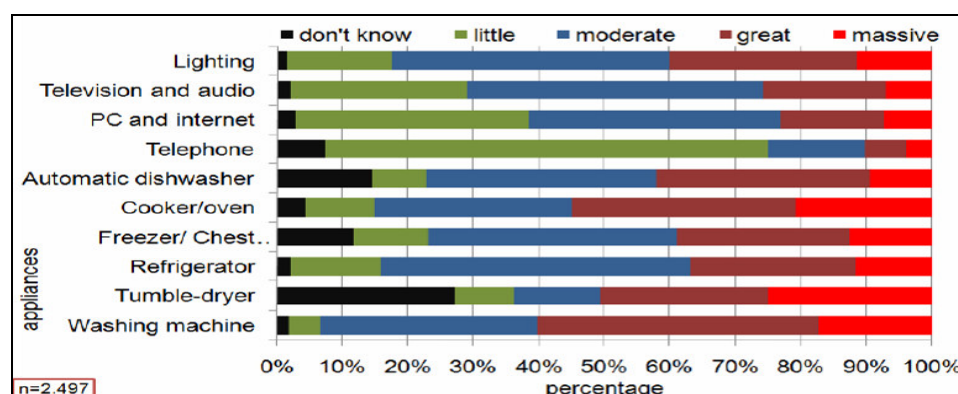

Figure 72: Consumers opinion about the influence of appliances on the overall energy consumption of a household

Source: R. Stamminger, Bonn University (D)

To identify barriers to ecodesign innovation and effective ways for their implementation, the consumer opinion about energy saving options on household appliances was analysed in the preparatory study for Lot 14.

Both for washing machines and dishwashers, the analysis of the answers shows that most of the consumers (more than 70%) would definitely use economic programmes but not necessary shorter programme times which rather lead to higher energy demand. For dryers, regarding potential lower temperatures or shorter programs to reduce the energy

consumption, they cannot lead to a more economic program if considered separately because they depend on each other: if the program temperature is lowered, the program duration will be longer, and vice-versa. Energy consumption could be reduced only by optimizing the parameters.

Towards environmental issues

For manufacturers and consumers, the Internet is the most commonly information channel about environmental issues

This section deals with how consumers inform themselves about environmental issues regarding household appliances.

According to the manufacturers survey (Figure 73), the most common information channels are the point of sale (for 67% of interviewed manufacturers), the Internet (60%) and independent test magazines (40%).

The company website is considered as a “medium” information channel by 60% of the interviewed manufacturers.

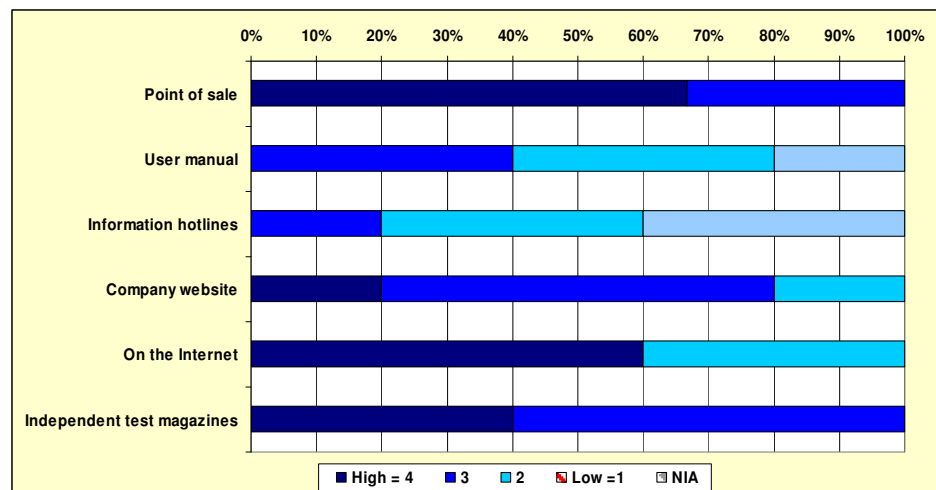

Figure 73: Information channels for consumers regarding environmental issues (according to manufacturers)

NIA = No Information Available

According to the consumer survey, the Internet is the most important information channel for consumers towards environmental issues (Figure 74). It is regarded as highly important or important (1 and 2) by 73 % of the respondents. It should be reminded that they respond to an ONLINE survey, and thus may be more familiar with the internet than the average. For the other channels (point of sale, own experience, user manual) the importance is quietly the same estimated as important by 70% of the respondents.

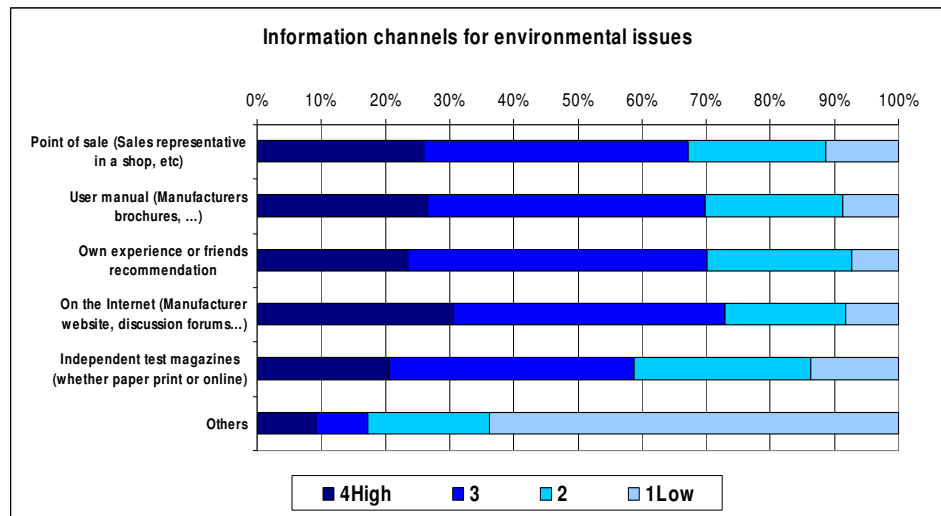

Figure 74: Information channels for environmental issues (according to consumers)

Regarding how to inform consumers on several kinds of environmental features, the manufacturers survey discloses that means are very equally used (Figure 75). Nevertheless it can be noticed that information is thought to be conveyed mostly through the user manual, the point of sale and sales people, the company website and the product sheet.

According to the type of information, the preferred channel differs. For example:

- “Ecolabels” through advertisement, point of sale and company website,
- “Energy consumption” through product sheet and company website,
- “Life time” through sales people
- “Recycling options” through packaging and user manual

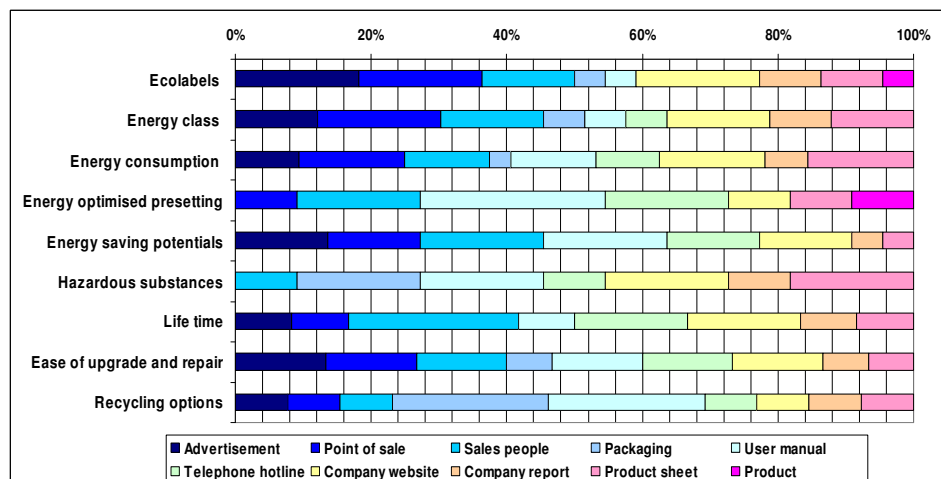

Figure 75: Consumer information ways on several kinds of environmental features (according to manufacturers)

Finally regarding how to enable the sales people to provide environmental information related to dryers (Figure 76), the manufacturers strategies mostly resort to product sheets and a part of general training (rather than special trainings).

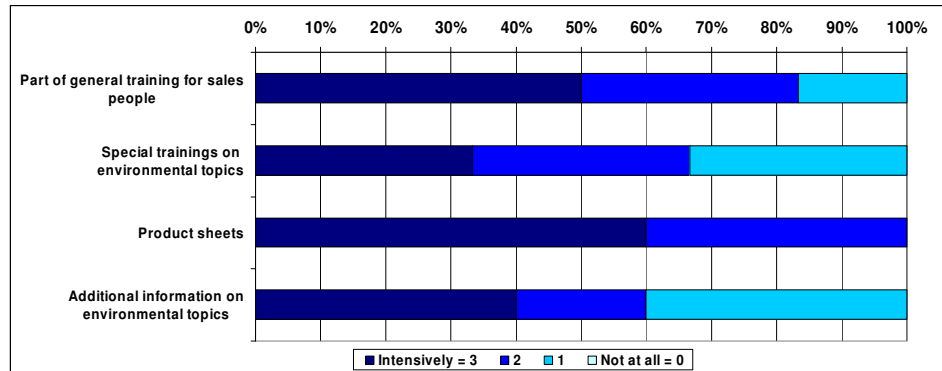

Figure 76: Information on environmental issues for sales people (according to manufacturers)

III.4 End-of-Life Behaviour

This section aims at identifying the consumer behaviour regarding end of life aspects of laundry dryers.

III.4.1 Actual time to disposal

The average actual time to disposal is 13 years. Most of the time used dryers are integrated in WEEE channels through collection points

Regarding the manufacturer opinion and some studies on the average duration of laundry dryers, the estimated life time is between 10 to 19 years. It is assumed that the average life time of dryers is 13 years.

Regarding the way of disposing of an old dryer, the consumer survey reveals that most of the time people use the selective communal collection of waste (32% of respondents) or respect the rule 1 for 1 (31% of respondents): when they buy a new appliance they return the old one (requirement coming from the WEEE Directive, 2002/96/CE, for household WEEE). The rates of the other ways to dispose of old dryers indicate few possibilities to extend the dryer life through second market or reuse.

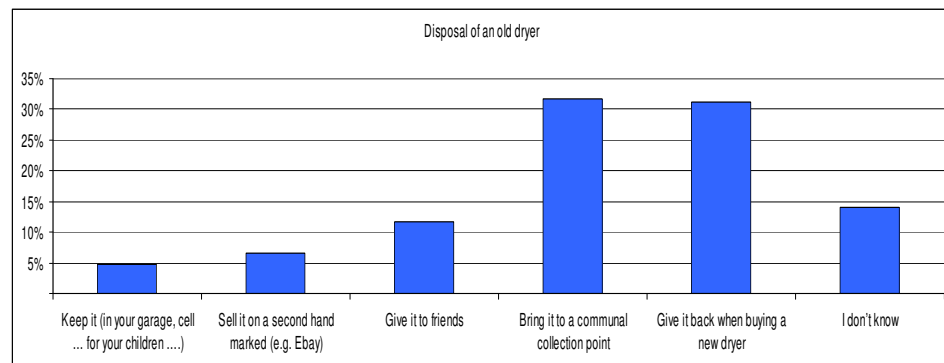

Figure 77: Scenarios for the disposal of an old dryer

III.4.2 Repair and Maintenance

35% of the consumers claim they would definitely repair their dryer and 41% claim they would probably do it.

As mentioned in the previous section, the repair and maintenance options are a way to allow the extension of the lifespan.

According to the consumer survey, more than 40% of the interviewed people envisage to probably repair the dryer and 35% to definitely repair it (Figure 78).

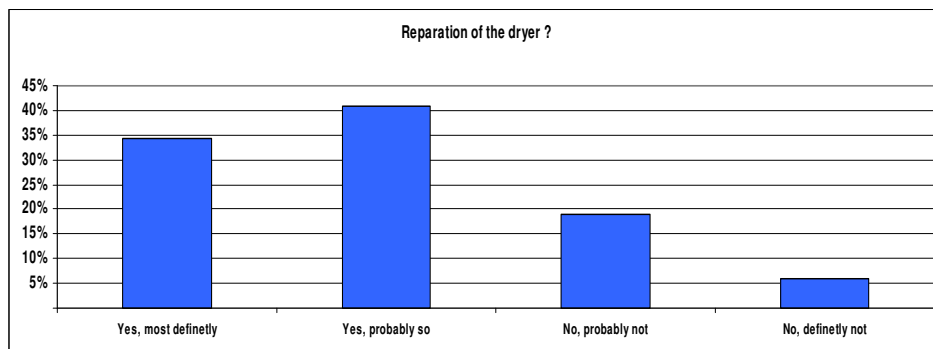

Figure 78: Envisaged reparation of the dryer

According to the consumer survey carried out by ODC for Lot 14 on washing machines, among the proportions of repaired or serviced appliances tumble dryers are at the third place behind washing machines and dishwashers with 14,9% of dryers repaired) as shown below.

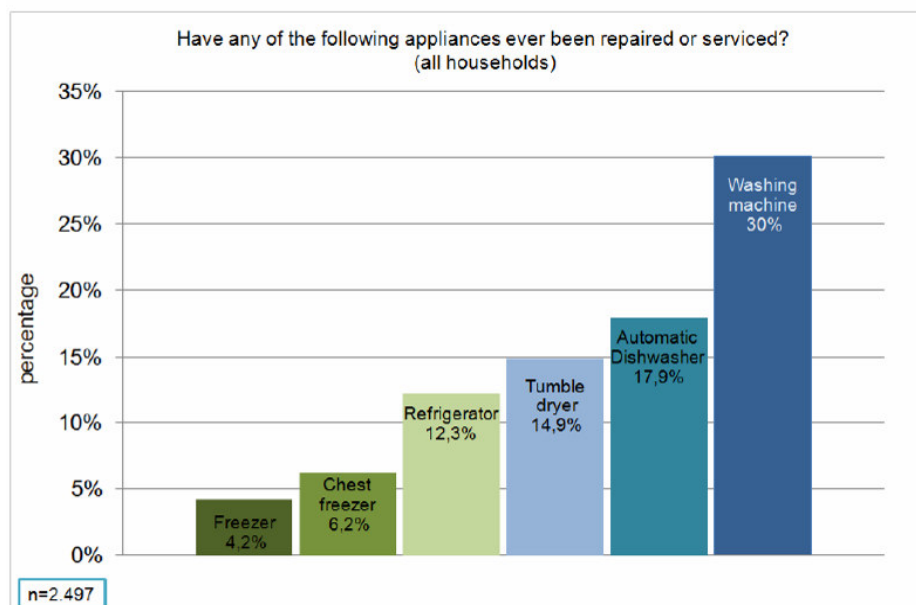

Figure 79: Proportion of repaired or serviced appliances

Source: ODC survey, Lot 14

III.4.3 Estimated second hand use

Less than 7% of laundry dryers are second-hand use purchased

Another possible barrier for the implementation of ecodesign barriers innovation is the stock of second-hand purchased appliances in households. Consumers may choose to replace broken or missing appliances by second-hand machines, which have lower performance than the new models on the market.

According to the data coming from the ODC survey for Lot 14: the share of tumble dryers purchased on the second-hand market represents only 6.6%.

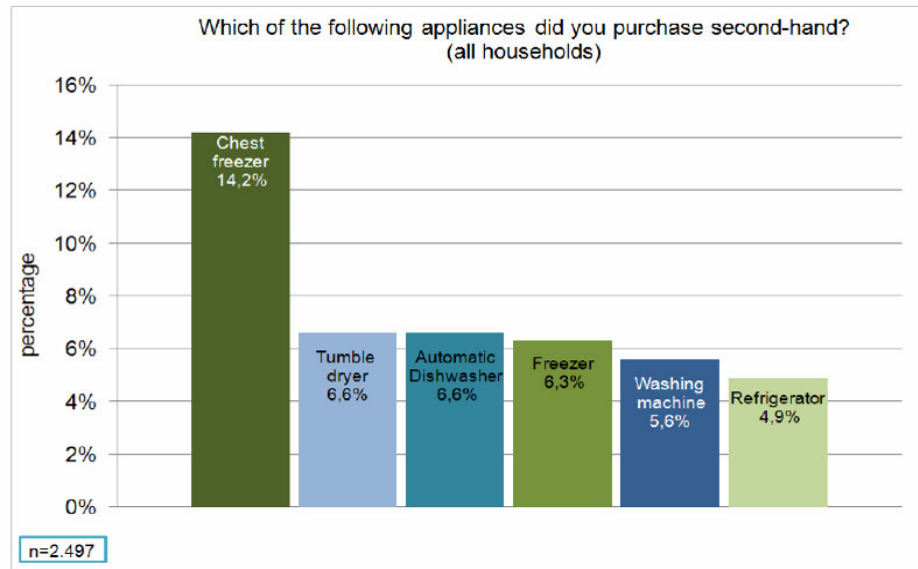

Figure 80: Proportion of second hand appliances

III.5 Local infrastructure

This section aims at identifying opportunities and obstacles linked to the local infrastructure which can influence the choice of dryers and the habits of consumers during the use phase. It includes reliability, availability and nature of energy, local tariff of energy and physical environment. Most of the collected information comes from the manufacturer survey.

III.5.1 Availability and nature of energy

For electric appliances

The cost of electrical energy reduces the demand for dryers. In Italy the maximum available peak energy is linked to cost of supply, therefore people try to keep the peak consumption below 3 kWh and their purchase behaviour is influenced (rather in favour of the A class equipment). Again in Italy, the electrical power supply (low installed) does not frequently allow that many appliances run at the same time (if no extra charge is paid), this is a potential limit in the usage of dryer like other household appliances.

For gas tumble dryers

The use of gas is only possible where a connection is available and dryers with exhaust air need a special tube for the exhausting. The main resistance from customer and trade is the installation issue and safety concern with gas.

III.5.2 Special energy tariffs

Special energy tariffs influencing the night usage of different appliances, and this affects the usage of the dryer. In combination with this usage conditions delay start function and silent operation are particularly important, especially if the dryer is installed close to the sleeping area then noise level is a parameter to take into account. In some areas there is no night tariff available.

III.5.3 Physical environment

According to the consumer survey on the living situations, the habits of consumers, the influence of the climate, several criteria can influence the choice of the type of dryers.

Due to the lack of place (as an example, in the Eastern Countries with an important amount of small flats / houses), numbers of laundry dryers with top loading, washer dryers combo or shared dryers in a spare space of the "community" (e.g at the basement of the building) are more important, specially in winter, in a heated room, with no clothes line alternative.

At the opposite if the physical environment is composed of large outside space (e.g. house, special area around the building) it can lead to an increasing amount of people using a clothes line to dry their laundry, thus specially in summer, sometimes in winter, in a sunny area (South of France for example).

Washing machines can be a part of the total drying process. With an improvement of its efficiency, especially with the development of higher spin speeds to reduce the initial moisture at the beginning of the drying stage.

If a tumble dryer is used in a heated room (at home), a fan or a conditioning system can be necessary. Besides, an air condenser dryer can be preferred in regards of an air vented dryer. Finally, using a tumble dryer inside an heated room can reduce the power consumption due to the heating system.

III.6 Elements for comparison between declared real life and standard conditions

The declared consumer behaviour with laundry dryers shows a variability and differences may be identified with the standard conditions defined in the European measurement methods to evaluate the consumption and the performance of appliances.

These differences are summarised in this part as far as they may influence the energy consumption of the laundry drying process.

The relevant factors for the energy consumption, which are not considered or may be considered under different conditions, are as follows in the standard conditions:

- Number of cycles per week and per person combined with season (summer / winter)
- Real loading of the dryer
- Type of fabrics
- Length of the drying cycle
- Remaining humidity after spin = nominal initial moisture content; it depends upon the washing machine spin speed
- Location of the dryer (in a heated room, in an unheated room)
- Use of a delay timer
- Behaviour at the end of the drying program (“on button”²⁹ situation)

For each factor are some elements of comparison based on the results analysis of the surveys:

	Standard conditions (EN 61121)	Declared real life conditions
Number of cycle per week and per person according to the season	Not defined	Summer: 2,3 per week and household 0,7 per week and person
Number of cycle per week and per person according to the season		Winter: 3,7 per week and household 1,1 per week and person
Loading of dryer:	Loading = Dryer capacity: 6 kg	Average loading per household: 3.4 ³⁰ kg
Type of fabrics	Dry cotton	Dry cotton
Length of the drying programme	Not defined (to be measured)	59.6 minutes
Remaining humidity after spin (= nominal initial moisture content)	For dry cotton: 60%	Measured according to the washing machine spin speed: Average spin speed: 1217 rpm Corresponding water remaining after spin in case of cotton ³¹ : 55%

²⁹ « On button » mode : mode which represents the status of the appliance at the end of a programme, while waiting for user attention

³⁰ value defined in real life base case of washing Machine for Lot 14

	Standard conditions (EN 61121)	Declared real life conditions
Location of the dryer: Ambient temperatures and humidity	Ambient temperature: 23°C Ambient humidity: 55%	8 different situations with 2 types of laundry dryers: Location in a heated room: In Summer 1/ Air vented dryer 2/ Condenser dryer In Winter 3/ Air vented dryer 4/ Condenser dryer Location in an unheated room: In Summer 5/ Air vented dryer 6/ Condenser dryer In Winter 7/ Air vented dryer 8/ Condenser dryer
Location of the dryer: Ambient temperatures and humidity (continued)	Ambient temperature: 23°C Ambient humidity: 55%	The ambient conditions (temperature and humidity) will be investigated for each situation with the usage of heating system in winter and cooling system in winter for the heated room case. Regarding each situation, energy consumption will depend on these conditions and calculated according to correction factors (Öko-Institut e.V, 2004) Air vented dryer: $\Delta E = (-0.01153 \cdot T + 0.231) \cdot 100$ Condenser dryers $\Delta E = (-0.0102147 \cdot T + 0.0.04293) \cdot 100$ With: ΔE = deviation from electricity demand at standard conditions in % and T: ambient temperature in °C
Use of a delay timer	Not included	Proposed use of the dryer with a delay timer and an average of delay of 2.5 hours . Regarding the power of the delay timer (see Table 4): 2,9W Energy consumption to add: 7.25 Wh
Behaviour at the end of the drying program: "on button" situation	Not included	Proposed behaviour with time before unload and turn off: Average time to unload: 24.6 minutes Regarding the power of the "on button" situation (see Table 4): 2,6W Energy consumption to add: 1.06 Wh

³¹ Öko-Institut e.V, 2004

III.7 Conclusion

The consumer survey was conducted on a sample composed of a majority of dryer-owning consumers from three European countries representing the North, the South and the East areas of Europe. The sample was chosen in order to get representative answers from owners of dryers and not to be representative in terms of the dryer penetration rate, which was queried from other sources.

The consumer survey reveals a rather low level of awareness of consumers towards the environmental issues related to laundry dryers. On one side; when buying decisions are taken, the purchase price and the running costs seem to be the criteria most commonly considered by consumers, the energy consumption and energy efficiency class, ranking third. Another study about the estimation by consumers of the influence of several appliances on the overall energy consumption of a household showed that more than 25% of consumers have no opinion regarding tumble dryers.

On another side, nevertheless, the European energy label is seen as an informational tool almost as important as the information available on the Internet. Regarding the consumer behaviour, the regular cleaning of some components such as the fluff filter or the heat exchanger and the fact that most of consumers switch off the dryers less than 30 minutes after the drying programme has finished, indicate that many people are aware about how to take care of their appliances in order to improve their useful life.

In European countries laundry dryers are available in less than 50% of the households (42.4% in UK, 34.6% in France and 5% in Poland) and these appliances remain in the household for normally ten years and more (average of 13 years for CECED). This time could be even longer in case of second-hand use appliances but the second-hand equipments account for a share of the market less than 7%.

Consumer behaviour has been identified as being the main source of influence on the actual energy consumption and environmental impacts.

The following results were obtained:

- The average drying frequency in summer is 2.3 cycles per week and household, and 3.6 in winter,
- The laundry dryer is located in a heated room in 37% of the cases and in an unheated room in 52% of the cases. Depending on the type of dryer technology (air vented or condenser) and the season (summer and winter), the energy consumption will depend, among others, on the use of a heating system (in summer) or a cooling system (in winter),
- Most consumers usually consider that they use the full loading capacity of their laundry dryer, but it is agreed that this does not mean that the rated capacity is really used,
- 76% of the laundry dryers are time-controlled (not automatic),
- The average spin speed of the washing machine (used before the drying process in the laundry care chain) was found to be 1217 rpm to be put in relation with the average spin speeds taken into account for the Lot 14 (on domestic washing machines) base-cases of 1129 rpm,
- Delay start options are used in less than 20% of the cycles with a delay of 2.5 hours on average,
- In 70% of the cases the dryer is switched off immediately or within 30 minutes after the program has finished. The average time during which the dryer may stay with the "on button" engaged is of 24,6 minutes.

Apart from the internal energy efficiency of the dryer (energy efficiency class), the individual consumer behaviour has a major influence on the amount of energy used in a laundry dryer. Indeed it should be highlighted that the use of the appliance at the rated capacity would increase its energy efficiency and would reduce the energy consumption if resulting in a lower number of drying cycles per week and household. Low power modes (delay timer and "on button" engaged), contribute to an extra energy consumption of the appliance in the real life.

Annexes to Task 3

H References

- CECED (2006), *Model database for tumble dryers in EU25*
- Central Statistical Office - *Population. Size and structure by territorial division. as of December 31, 2007*; available at: www.stat.gov.pl/cps/rde/xbcr/gus/PUBL_population_size_structure_31_12_2007.pdf
- Institut National de la Statistique et des Études Économiques, *Bilan démographique 2007: des naissances toujours très nombreuses*
- Market Transformation Programme (2007), *BNXS15: Standby power consumption – domestic appliances*, version 1.4, 5 November 2007, UK
- MTP programme “BNW06: Assumptions underlying the energy projections for domestic tumble driers v 3.1”, page 3; 2007
- National Statistics, *Population Estimates - UK population grows to more than 60 million*
- Öko-Institut e.V (2004), *Energy demand of tumble dryers with respect to differences in technology and ambient conditions*, Final Report, commissioned by European Committee of Domestic Equipment Manufacturers (CECED), Freiburg, 13 January 2004, Authors Ina Rüdener, Carl-Otto Gensch

I Summary of comments from stakeholders

Submitted by	Comment	Response
2 nd stakeholder meeting	<p>The media of the survey (internet) might imply a sample of young households. As consequence they might possess rather “new” appliances that could explain the age of the dryers (rather low) and the high proportion of condenser dryers.</p> <p>The proportion of moisture control should be higher than the results; the fact that owners do not necessarily know the type of control of their dryer could explain this result. It should be noted that the trend specified in the survey (higher time control) can be influenced by the UK market where the proportion of time control is higher.</p> <p>The high proportion of dryers belonging to classes A and B was questioned. This issue can be explained by a high percentage of households which don't know the Energy Efficiency Class of their dryer or overestimate thinking it might be the “right” answer.</p> <p>The question of the power switch that might be confused with start button was underlined and highlight that the results have to be considered with caution.</p> <p>The average capacity of 4.5 appeared too high to the stakeholders. Logically the average load to be considered in the base case should be the same as for washer-dryers defined in Lot 14 (3.4 kg)</p> <p>CECED indicated that in Poland the market share of washer-dryer is now decreasing.</p> <p>It was suggested to rename the section, “declared real life behavior” to avoid controversial conclusions.</p> <p>Some of the parameters queried from the survey respondents are difficult to estimate by end users.</p> <p>Which are the parameters most difficult to estimate by the end user?</p> <p>The spin speed of washing machines is considered rather high.</p>	<p>The text describing Figure 18 on page 121 has been adapted to point out this assumption, and refers to the section “Age of dryers” on page 134.</p> <p>The section “Type of dryers and loading possibilities” on page 128 now includes the remark regarding condenser dryers.</p> <p>The section “Type of control” on page 131 has been expanded to reflect these remarks.</p> <p>The section “Energy efficiency class of dryers” on page 133 has been expanded accordingly.</p> <p>The section about “Power switch” on page 148 has been expanded to reflect this fact.</p> <p>The section “Load” on page 146 now incorporates this information.</p> <p>The relevant part of section “Type of dryers and loading possibilities” on page 128 has been expanded to include this.</p> <p>In section 7, the conditions which are compared are standard conditions with declared real life conditions</p> <p>Reiterated in different parts of the document to emphasize the importance.</p> <p>A list of these parameters has been added on page 119.</p> <p>An evaluation of the survey data has been included that shows the age of the dryers to increase with the age of the respondents (see “Age of dryers” on page 134). This fact possibly indicates a trend that lower ages correlate with rather new household machines in general. Comments have been added to section “Washing machine spin speed” on page 143 to point out this fact.</p>

Submitted by	Comment	Response
	<p>Is there a dependence of the drying time on the average dryer load?</p> <p>Average rated capacity for Tumble Dryers</p> <p>In page 131 of the report, the following statement is made: According to the detailed data (% of answers), the range of possible capacity is between 4.5kg (bottom margin range) and 6.9kg (top margin range) and the average capacity of a dryer is 5.7 kg (middle range). Nevertheless, this could be challenged due to the chosen ranges of capacities (less than 4kg, 4 to 6 kg, etc) and the large share of people who do not know the capacity of their dryer. It represents a large quantity of uncertainties.</p> <p>Because of the possible sources of inaccuracy of the survey already addressed to the consultants, we do not believe that stating an average value for the capacity of the range of persons questioned is accurate. Therefore, we propose that the mean average capacity is determined as a value between 4 and 6 kg, without specifying an average load. The proposed phrase could read as follows: <i>According to the detailed data the average capacity of a dryer is in the range 4-6 kg.</i></p>	<p>Figure 40 on page 135 shows the detailed results.</p> <p>The section “Capacity of dryers” on page 131 has been adapted to underline the difficulty of calculating an average capacity from the answers that were given in ranges. The idea of completely dropping the average capacity value from the text has, however, not been implemented yet.</p>
CECED / Patricia López Blanco	<p>Energy Efficiency Class of Dryers</p> <p>On page 131 of the report the following statement regarding the energy efficiency classes is made: <i>“According to a manufacturer, the sale and use of certain classes of tumble dryers can greatly depend upon the availability of power supply. For example in Italy, an A class dryer has a very high penetration rate, probably because of restrictions on the maximum current available in this country, and because this A class dryer requires a much lower voltage.”</i> We believe that this statement is not accurate or not clearly stated. In Italy the energy rate, per each household, is linked to the maximum available power. At the lowest rate the allowable power is 3 kW, this allowable power can be higher depending on the household. Therefore this is not a direct relation to the presence of more A class appliances in Italy. Therefore, we believe that this comment should be either excluded or better reported.</p>	<p>Sources http://www.onestopitaly.com/faqs.html and http://2italy.blogspot.com/2007/03/italian-electrical-issues.html indicate the 3 kW power limit is commonly encountered in Italian households. The text on page 133 has been adapted.</p>

Submitted by	Comment	Response
CECED / Patricia López Blanco	<p>Conclusion – Representativity of the Sample</p> <p>In page 166 of the report the following phrase is stated: “Consumer survey on a representative sample of consumers from 3 European countries representing the North, the South and the East areas of Europe, reveals a rather low level of awareness of consumers towards the environmental issues related to laundry dryers.” Given the several comments on the representativity of the sample (86% of consumers owned a dryer) we believe that some precisions should be made in this paragraph. First of all, the words representative sample of consumers should be deleted and replaced by sample composed by a majority of Laundry Dryers consumers. Furthermore we believe that a phrase explaining the reasons why the survey was mainly focused on Laundry dryers consumers.</p>	<p>On page 120, the rationale for choosing a sample from highly penetrated population strata is given.</p> <p>On page 120, the selection criteria now indicate the deliberately chosen percentage of persons owning a dryer.</p> <p>Finally, the conclusion on page 166 has been adapted accordingly.</p>
<p>Öko-Institut e.V. / Ina Rüdener</p> <p>Öko-Institut e.V. / Ina Rüdener</p> <p>Öko-Institut e.V. / Ina Rüdener</p> <p>Öko-Institut e.V. / Ina Rüdener</p>	<p>p.15, 1 The age of the interviewed persons should be compared to the average age of the population in the regarded countries to identify a possible age bias. (this might be possible as the people were only interviewed with internet questionnaires and would explain some of the results, e.g. young age of dryers in stock or high spin speed of washing machines in stock).</p> <p>p.17, 4 What is the difference between “apartment / flat” and “multi-family house”?</p> <p>p.22 Sentence unclear: “These detailed results confirm that the major type of dryers on the market could be the air vented technology (particularly in Western Europe).” According to task 2-report and table 2 in task 3-report the major type currently on the market is the condenser type.</p> <p>p.24 Second paragraph (starting with “as for the washer-dryer, the consumer survey...”) unclear. Also the cited information cannot be found in table 3.</p>	<p>Some comments on this aspects have been added (page 120)</p> <p>Apartment / flat means a specific place for each family with their own dryer rather than in a multi-family house where several families leaving in the same house can share the appliances such a dryer.</p> <p>The sentence has been changed: “<i>These detailed results confirm that the major type of dryers on the market could be the air vented technology (particularly in Western Europe). Nevertheless, regarding this trend, it must be stressed that 11% of respondents do not know the type of their dryers.</i>”</p> <p>The sentence has been changed: “<i>For the washer-dryers, the consumer survey shows that this technology ranks third in Europe (14% of respondents, by taking into account the penetration rates in the three countries).</i></p> <p><i>Regarding the market data in 2005, their sales represent only 31% of the sales of air condenser technologies in Europe (Table 37 and Table 37). This is close to the consumer survey results (45% of respondents for air vented technology and 14% for washer-dryers).</i></p>

Submitted by	Comment	Response
<p>Öko-Institut e.V. / Ina Rüdener</p>	<p>p.26 The current market share of moisture controlled dryers would be helpful to judge if there is a need for action. It can be generally assumed that moisture controlled dryers use much less energy under real life conditions than time controlled. If there are still time controlled dryers on the market, moisture control should be defined as improvement option for such dryers.</p>	<p>It has been decided to choose a “moisture controlled” appliance as base-case. The time controlled version will be considered as potential improvement with negative impacts.</p>
<p>Öko-Institut e.V. / Ina Rüdener</p>	<p>p.27, 19 Usually Figure s are kept in mind very well. As the high share of dryers of energy efficiency classes A and B in stock is obviously not possible, it should therefore not be depicted in a and thus highlighted.</p>	<p>We prefer to let the Figure s to show the high rate of “I do not know” answer that seems to indicate a lack of interest of consumers about the energy performance of their dryers and possibly a lack of information on the potential reduction of energy consumption they could enjoy when buying a class A or B appliance.</p>
<p>Öko-Institut e.V. / Ina Rüdener</p>	<p>p.46, cleaning of components This issue of cleaning is highly relevant, especially for heat pump dryers. The energy and time demand of a drying cycle strongly increases if the heat exchanger is not cleaned regularly. Possible improvement options could include either technological solutions (self cleaning) or e.g. an LED lamp indicating the need for cleaning, as mentioned for the cleaning of the fluff filter. The conclusion “The fluff filter is most of the time cleaned after each drying cycle” is not correct. Only 36% of all respondents clean it after each drying cycle, 64% don't.</p>	<p>OK, the following sentence has been added: <i>“Then 64% of respondents do not clean the fluff filter after each drying cycle, with the risk of an increased energy demand due to this behaviour.”</i></p>
<p>Öko-Institut e.V. / Ina Rüdener</p>	<p>p.47 The conclusion “74% of consumers iron their laundry after drying” is a bit too general. It should be inserted “... always or often...”. Especially as 62% always and often do not iron their laundry at all but put it straight away (according to your results, see last sentence p. 47 and 48).</p>	<p>The comment has been changed as follows: <i>“According to the consumer survey, 25% of the persons interviewed always iron the dry laundry directly after drying and 22% put the clothes on straight away (Figure 66). Regarding both answers “always” and “often” for the situations “iron the laundry” or “put it directly away”, it comes that 74% of respondents iron their laundry always or often while 62% put it directly away always or often. These Figure s indicate a slight “preference” for the ironing.”</i></p>

Submitted by	Comment	Response
<p>Öko-Institut e.V. / Ina Rüdener</p>	<p>p.52 First paragraph a bit unclear: also in case of washing machines and dishwashers shorter programme times do not lead to lower but rather to higher energy demand of the respective programme.</p>	<p>The paragraph has been changed as follows: <i>“Both for washing machines and dishwashers, the analysis of the answers shows that most of the consumers (more than 70%) would definitely use economic programmes but not necessary shorter programme times which rather lead to higher energy demand. For dryers, regarding potential lower temperatures or shorter programs to reduce the energy consumption, they cannot lead to a more economic program if considered separately because they depend on each other: if the program temperature is lowered, the program duration will be longer, and vice-versa. Energy consumption could be reduced only by optimizing the parameters.”</i></p>
<p>Öko-Institut e.V. / Ina Rüdener</p>	<p>p.55 Conclusion “Most of the consumers (75%) claim they would try to repair their dryer” is too general. It should be inserted “... probably or definitely...”, as only 35% would definitely repair it.</p>	<p>The following conclusion has been included: <i>“34% of the consumers claim they would definitely repair their dryer and 41% claim they would probably do it.”</i></p>
<p>Öko-Institut e.V. / Ina Rüdener</p>	<p>p.58 Paragraph “The cost of electrical energy reduces the demand for dryers, In Italy the maximum available peak energy is linked to cost of supply, therefore people try to keep the peak consumption below 3 kWh and their purchase behaviour is influenced.” is unclear and should be rephrased.</p>	<p>The following changes have been done: <i>“The cost of electrical energy reduces the demand for dryers, In Italy the maximum available peak energy is linked to cost of supply, therefore people try to keep the peak consumption below 3 kWh and their purchase behaviour is influenced (rather in favour of the A class equipment). Again in Italy, the electrical power supply (low installed) does not frequently allow that many appliances run at the same time (if no extra charge is paid), this is a potential limit in the usage of dryer like other household appliances.”</i></p>
<p>Öko-Institut e.V. / Ina Rüdener</p>	<p>p.62 It is true that consumer behaviour has an important influence on the real life electricity demand of a tumble dryer (e.g. via actual loading or the cleaning of the heat exchanger). However another, at least as important factor for the electricity demand is the specific efficiency of the dryer, i.e. the energy efficiency class of the dryer. For example, a condenser dryer with a heat pump (energy efficiency class A) consumes only half of the electricity compared to a conventional condenser dryer of the energy efficiency class B.</p>	<p>The conclusion has been changed as follows: <i>“Apart from the internal energy efficiency of the dryer (energy efficiency class), the individual consumer behaviour has a major influence on the amount of energy used in a laundry dryer....”</i></p>
<p>Öko-Institut e.V. / Ina Rüdener</p>	<p>p.63 Sentence “It is then switched off in 70% of the cases.” is not correct. In 70% of the cases the dryer is switched off immediately or within 30 minutes after the program has finished, not after 24.6 minutes.</p>	<p>The sentence has been adapted as follows: <i>“In 70% of the cases the dryer is switched off immediately or within 30 minutes after the program has finished. The average time during which the dryer may stay with the “on button” engaged is of 24,6 minutes.”</i></p>

J Questionnaires

Consumer questionnaire

Consumer profile

Detail	Please enter your details below
Area (multi selection)	<ul style="list-style-type: none"> ▪ North ▪ South ▪ Middle ▪ East ▪ West
Do you live in a (one selection)	<ul style="list-style-type: none"> ▪ Apartment/Flat ▪ One family house ▪ Multi family house ▪ Flat-sharing community ▪ Hall of residence ▪ Other
Number of people living in the same place (open question)(number)	
Your age (one selection)	<input type="checkbox"/> below 20years <input type="checkbox"/> 20-29 years <input type="checkbox"/> 30-39 years <input type="checkbox"/> 40-49 years <input type="checkbox"/> 50-59 years <input type="checkbox"/> 60-69 years <input type="checkbox"/> over 70 years
Your gender (one selection)	<ul style="list-style-type: none"> ▪ Female ▪ Male

Consumer behaviour

▪ Opening question

1. How do you dry your laundry in summer?

(please respond to all options indicating: always; often; sometimes; rarely; never)

- In the flat/house in an indoor unheated room and not in an appliance
- In the flat/house in an indoor heated room and not in an appliance
- Outside, on the clothes line
- In a cabinet dryer (at home)
- In a tumble dryer (at home)
- In a launderette
- In a communal laundry room (in a laundry dryer)
- Other (please specify)

2. How do you dry your laundry in winter?

(please respond to all options indicating: always; often; sometimes; rarely; never)

- In the flat/house in an indoor unheated room and not in an appliance
- In the flat/house in an indoor heated room and not in an appliance
- Outside, on the clothes line
- In a cabinet dryer (at home)
- In a tumble dryer (at home)
- In a launderette
- In a communal laundry room (drying cabinet) (in a laundry dryer)
- Other (please specify)

▪ **Your dryer**

Condition: Answer to question 1 and 2 point "in a cabinet dryer" and "in a tumble dryer" was not "never"

3. Please specify the purchase price (in Euros) (one selection)

- Less than 200€
- 200€-399€
- 400€-599€
- Equal or more than 600€

4. Please specify the age of the dryer (years): (one selection)

- Less than 3 years
- 3-5 years
- 6-9 years
- Equal or more than 10 years

5. Which kind of dryer do you use? (one selection for top or front loading and one selection for the other points)

- | | | | |
|------------------------------------|--------------------------|---------------|--------------------------|
| ▪ Top loading | <input type="checkbox"/> | Front loading | <input type="checkbox"/> |
| ▪ Electric Air vented tumble dryer | | | <input type="checkbox"/> |
| ▪ Gas Air vented tumble dryer | | | <input type="checkbox"/> |
| ▪ Air condenser tumble dryer | | | <input type="checkbox"/> |
| ▪ Water condenser tumble dryer | | | <input type="checkbox"/> |
| ▪ Heat pump dryer | | | <input type="checkbox"/> |
| ▪ Washer-dryer | | | <input type="checkbox"/> |
| ▪ Drying cabinet | | | <input type="checkbox"/> |
| ▪ Other, specify: _____ | | | <input type="checkbox"/> |
| ▪ <i>I do not know the type</i> | | | <input type="checkbox"/> |

6. The energy class of the dryer (A, B, C, ...): (one selection)

- A
- B
- C
- D
- E
- F
- Do not know

7. The capacity of the dryer (in kg of fabric): (one selection)

- Less than 4kg
- 4-6kg
- 7-10 kg
- More than 10kg
- Do not know

8. How is the runtime of the dryer controlled? (one selection)

- Time controlled
- Moisture controlled
- Do not know

9. Which programs are available at your dryer? (multi selection)

- Cotton
- Synthetic
- Easy care
- Mixed
- Wool
- ...
- Other (please specify)

▪ **Your behaviour for dryer usage**

At home

Condition: Answer to question 1 and 2 point "in a cabinet dryer" and "in a tumble dryer" was not "never"

10. Where is the dryer located? (one selection)

- Outside
- Heated room
- Unheated room
- Other

11. How do you ventilate the room during drying (if the dryer is located inside the household)?

- Naturally (opening window, door...)
- Mechanically (ventilation system...)
- I do not ventilate the room

12. How many times/cycles per week is the dryer used in summer? (type in a number)

13. How many times/cycles per week is the dryer used in winter? (type in a number)

14. How do you load your dryer? ((please respond to all options indicating: always; often; sometimes; rarely; never))

- The way I load the machine depends on the kind of laundry
- I run the drying machine regardless of how much of its capacity is used
- I run the machine even with a relatively small amount of laundry inside
- I do not usually fill the machine completely
- I use the machine's full capacity without overloading it
- I load the machine in such a way that it is almost overloaded

15. How many dry load (kg) would you estimate the usual/average load? (one selection)

- Less than 3kg
- 3-5kg
- 6-8kg
- 9-10kg
- More than 10kg
- Do not know

16. Which spin speed (of washing machine) do you usually use before drying? (please respond to all options indicating: always; often; sometimes; rarely; never)

- 1600-1800
- 1400-1550
- 1200-1350
- 1000-1150
- 800-950
- 500-750
- Do not know.

17. Do you use a start delay function?

(Response options: always; often; sometimes; rarely; never; option not available in the dryer)

18. Why do you use this function? (Open question)

Condition: Question 17 was not "never"

19. Which start delay do you select in average? (one selection)

Condition: Question 17 was not "never"

- Less than 3 hours
- 4-6 hours
- More than 7 hours
- Do not know

20. What is (are) the drying program(s) that you mostly use? What type of drying options do you usually select and how often ?

Please provide the different programmes to be possibly used

(response options: always; often; sometimes; rarely; never)

- List of the points selected in question 9

21. Why do you use these programs? (Open question)

22. Do you use "consumables" as for example: wipe for a sweet perfume?

Yes

No

If yes, how much and which ones?

23. How long does a drying cycle usually take? (one selection)

- Less than 30 minutes
- 30-59 minutes
- 60-89 minutes
- 90-120 minutes
- More than 120 minutes
- Do not know

24 How long does it usually take until you unload turn off the dryer after the program has finished? (one selection)

- Immediately after the program has finished
- Less than 30 minutes after the program has finished
- 30 – 90 minutes after the program has finished
- More than 90 minutes after the program has finished
- Do not know

25 Has your dryer a power switch (yes; no; I do not know)

26 If yes do you switch off the dryer after you have unloaded after the programme has ended? (one selection) (response options: always; often; sometimes; rarely; never)

27. How often do you clean the fluff filter in your dryer? (one selection)

- After/Before each drying cycle
- At least once a week
- At least once a month
- At least once a year
- According to the indication of the dryer control
- Never

28. If you have a condenser dryer, how often do you clean the heat exchanger in your dryer? (one selection)

- After/Before each drying cycle
- At least once a week
- At least once a month
- At least once a year
- According to the indication of the dryer control
- Never

29. What do you do with the laundry once it is dry?

(please respond to all options indicating: always; often; sometimes; rarely; never)

- Put it directly away with the laundry ready to be worn
- Iron it
- Put it on hangers so that it finishes to dry: inside a heated room/inside a non heated room/outside and then put it away
- Put it on hangers so that it finishes to dry: inside a heated room/inside a non heated room/outside and then iron it

30. What kind of ironing program do you normally use?

- Cotton
- Wool
- Synthetic
- Easy care

- Mixed
- Steam programme
- Other (please specify)

31. Other relevant information (please specify): (open question)

In the laundry room (in a laundry dryer) of an apartment house

Condition: Answer to question 1 and 2 point "In the laundry room (in a laundry dryer) of a apartment house" was not never

32. How many households are using the laundry dryer? (one selection)

- 1
- 2-3
- 3-5
- 5-7
- More than 7
- Do not know

33. Would you share your drying resource with others instead of having your own dryer? If yes, would it be because: (one selection)

- Cost reduction
- Energy efficiency
- Small apartment space
- Other (please specify)

▪ **End of life behaviour**

Condition: Answer to question 1 and 2 point "in a cabinet dryer" and "in a tumble dryer" was not "never"

34. How do you dispose of an old dryer? (one selection)

- Keep it (in your garage, cell ... for your children)
- Sell it on a second hand market (e.g. Ebay)
- Give it to friends
- Bring it to a communal collection point
- Give it back when buying a new dryer
- Do not know

35. Would you try to have your dryer repaired rather than buy a new one (in case of malfunction)? (response options: Yes most definitely; yes probably so; no probably not; no, definitely)

▪ **Buying decision**

36. When making a trade off between purchase price and power consumption, what payback period would you consider? (one selection)

- 1-2 years,
- 3-4 years,
- More than 4 years

37. To what extent do the following aspects play a decisive role in your buying decision?

General aspects	Low			High
Brand image	<input type="checkbox"/>	<input type="checkbox"/>	<input type="checkbox"/>	<input type="checkbox"/>
Purchase price	<input type="checkbox"/>	<input type="checkbox"/>	<input type="checkbox"/>	<input type="checkbox"/>
Estimated running costs	<input type="checkbox"/>	<input type="checkbox"/>	<input type="checkbox"/>	<input type="checkbox"/>
Offer of service (guarantee, ...)	<input type="checkbox"/>	<input type="checkbox"/>	<input type="checkbox"/>	<input type="checkbox"/>
Technology / Performance	<input type="checkbox"/>	<input type="checkbox"/>	<input type="checkbox"/>	<input type="checkbox"/>
Environmental aspects (e.g. Energy consumption)	<input type="checkbox"/>	<input type="checkbox"/>	<input type="checkbox"/>	<input type="checkbox"/>
Installation restrictions (front/top loader, restrictive space/access, gas dryers connection)	<input type="checkbox"/>	<input type="checkbox"/>	<input type="checkbox"/>	<input type="checkbox"/>
General aspects	Low			High
Capacity <i>Volume of the drum</i>	<input type="checkbox"/>	<input type="checkbox"/>	<input type="checkbox"/>	<input type="checkbox"/>
Functionality <i>(automatic control, programs, ...)</i>	<input type="checkbox"/>	<input type="checkbox"/>	<input type="checkbox"/>	<input type="checkbox"/>
Aesthetic Appeal	<input type="checkbox"/>	<input type="checkbox"/>	<input type="checkbox"/>	<input type="checkbox"/>
Longer Lifetime	<input type="checkbox"/>	<input type="checkbox"/>	<input type="checkbox"/>	<input type="checkbox"/>
Others Please specify: _____	<input type="checkbox"/>	<input type="checkbox"/>	<input type="checkbox"/>	<input type="checkbox"/>
Environmental aspects	Low			High
Energy consumption <i>(Energy label: Class A, B, ...)</i>	<input type="checkbox"/>	<input type="checkbox"/>	<input type="checkbox"/>	<input type="checkbox"/>
Power saving functions	<input type="checkbox"/>	<input type="checkbox"/>	<input type="checkbox"/>	<input type="checkbox"/>
Use of recycled materials	<input type="checkbox"/>	<input type="checkbox"/>	<input type="checkbox"/>	<input type="checkbox"/>
Emissions (in gas dryer case)	<input type="checkbox"/>	<input type="checkbox"/>	<input type="checkbox"/>	<input type="checkbox"/>
Proven longer life time in use cycle	<input type="checkbox"/>	<input type="checkbox"/>	<input type="checkbox"/>	<input type="checkbox"/>
Use of environment friendly materials	<input type="checkbox"/>	<input type="checkbox"/>	<input type="checkbox"/>	<input type="checkbox"/>
Reuse and recycling options	<input type="checkbox"/>	<input type="checkbox"/>	<input type="checkbox"/>	<input type="checkbox"/>
Others Please specify: _____	<input type="checkbox"/>	<input type="checkbox"/>	<input type="checkbox"/>	<input type="checkbox"/>

38. Which information channels do you preferably use to inform yourselves about environmental features?

	Low			High
Point of sale <i>(Sales representative in a shop, etc)</i>	<input type="checkbox"/>	<input type="checkbox"/>	<input type="checkbox"/>	<input type="checkbox"/>
User manual <i>(Manufacturers brochures, ...)</i>	<input type="checkbox"/>	<input type="checkbox"/>	<input type="checkbox"/>	<input type="checkbox"/>
Own experience or friends recommendation	<input type="checkbox"/>	<input type="checkbox"/>	<input type="checkbox"/>	<input type="checkbox"/>
On the Internet <i>(Manufacturer website, discussion forums...)</i>	<input type="checkbox"/>	<input type="checkbox"/>	<input type="checkbox"/>	<input type="checkbox"/>
Independent test magazines <i>(whether paper print or online)</i>	<input type="checkbox"/>	<input type="checkbox"/>	<input type="checkbox"/>	<input type="checkbox"/>
Others Please specify: _____	<input type="checkbox"/>	<input type="checkbox"/>	<input type="checkbox"/>	<input type="checkbox"/>

Manufacturer questionnaire

Products

Please provide the list of product you manufacture and their configuration in completing the following table. We already specified three main product types:

- T1: Electric Tumble Dryers
- T2: Gas Tumble Dryers
- T3: Drying Cabinets
- T4: Washer Dryers

Are there are any other types of laundry dryers that you think this study should consider? If yes, please complete the table below and specify the reasons why they should be considered.

Please describe your products by sub-categories in completing the third column, feel free to add as many product sub-category as you judge necessary.

Could you please use as far as possible the classification below for electric tumble dryers?

Electric tumble dryers

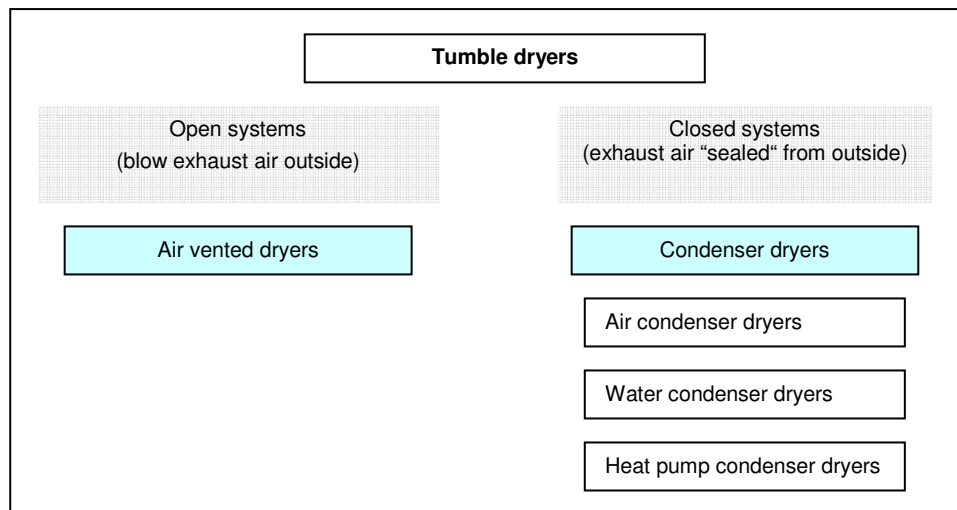

Could you specify also the type of loading for each product (top- or front-loader)?

N°	Product	Product sub-category description
T1	Electric tumble dryers	
T2	Gas tumble dryers	
T3	Drying cabinets	
T4	Washer Dryers	
Other		

▪

▪ **Market data**

Type of client:

Retailers are in general the most important distribution channels for laundry dryers. Does your company have any other type of clients (e.g. small scale retailers, internet, direct sales, etc...)?

Yes

No

If Yes

Who are your other clients? _____

What is the share of units (and value) sold to the other clients compared to the major retailer clients?

Could you please specify the format of your clients in the retailing market? For example: specialised supermarkets, wholesale, etc.

To which extent are the products sold directly over the Internet? How are the distribution channels organised?

▪ **Consumer behaviour and local infrastructure**

Consumer behaviour is a very relevant input for the assessment of the environmental impact and life cycle costs of a product.

One aim of the preparatory studies is to identify barriers and restrictions to possible eco-design measures due to social, cultural or infra-structural factors such as lack of knowledge, convenience, force of habits, costs, etc

A second aim is to quantify relevant user parameters that influence the environmental impact during the product lifetime and that are different from present standard test conditions for the product. Indeed, there is huge potential to improve the use of ecodesign products and to reduce energy consumption by influencing the consumer behaviour.

The intention of this questionnaire is to collect data or studies related to the way you, as a manufacturer of laundry dryers, take into account consumer behaviour as well as environmental and energy efficiency requirements in the design of your products. It also attempts to explore how consumer behaviour affects the performance of these appliances during their use phase in terms of energy consumption and environmental impact.

If you are aware of or have specific studies regarding consumer behaviour, you should send it through email directly to mjanin@codde.fr.

The questionnaire is subdivided into two main parts:

Consumer behaviour

The objective of this section is three fold. We seek to:

- understand the level of environmental consciousness of an European consumer,
- analyse the manner in which an average consumer chooses and then uses this energy using product,
- identify the potential and means to influence such behaviour in order to improve the energy efficiency and reduce the environmental impacts throughout the life-cycle of this product

Information for consumers

The environmentally-friendly consumer behaviour is also related to the state of information they receive from the manufacturers.

We would like to identify which information is provided and to which extent the sales staff and consumers already know about eco-design and energy efficiency.

This section seeks to identify the kind and level of information communicated to the consumer by the companies, through advertising, marketing, and/or in product brochures, user manuals and other technical documentation.

▪ **Consumer behaviour**

Available information and studies on consumer behaviour

Did your company carry out or subcontract certain studies or surveys concerning private and/or business consumers' behaviour? Or do you have other sources of information on consumer behaviour in this context?

Yes No

If Yes, Please specify these studies: _____

Do these above-mentioned studies consider any aspects of eco-design?

Yes No

If Yes, Please specify: _____

Do these above-mentioned studies consider any aspects of energy efficiency?

Yes No

If Yes, Please specify: _____

Which of these studies could you make available to us as a whole or in part?

Consumers' Buying Decision

To what extent do the following aspects play a decisive role in consumers' buying decision?

General aspects	Low			High		NIA*
Brand image	<input type="checkbox"/>	<input type="checkbox"/>	<input type="checkbox"/>	<input type="checkbox"/>	<input type="checkbox"/>	<input type="checkbox"/>
Purchase price	<input type="checkbox"/>	<input type="checkbox"/>	<input type="checkbox"/>	<input type="checkbox"/>	<input type="checkbox"/>	<input type="checkbox"/>
Offer of service (guarantee, ...)	<input type="checkbox"/>	<input type="checkbox"/>	<input type="checkbox"/>	<input type="checkbox"/>	<input type="checkbox"/>	<input type="checkbox"/>
Technology / Performance (Electric air vented, condensation or heat pump, gas)	<input type="checkbox"/>	<input type="checkbox"/>	<input type="checkbox"/>	<input type="checkbox"/>	<input type="checkbox"/>	<input type="checkbox"/>
Design Type of loading: front / top	<input type="checkbox"/>	<input type="checkbox"/>	<input type="checkbox"/>	<input type="checkbox"/>	<input type="checkbox"/>	<input type="checkbox"/>
Capacity Volume of the drum	<input type="checkbox"/>	<input type="checkbox"/>	<input type="checkbox"/>	<input type="checkbox"/>	<input type="checkbox"/>	<input type="checkbox"/>
Functionality (automatic control, programs, ...)	<input type="checkbox"/>	<input type="checkbox"/>	<input type="checkbox"/>	<input type="checkbox"/>	<input type="checkbox"/>	<input type="checkbox"/>
Design / Aesthetic Appeal	<input type="checkbox"/>	<input type="checkbox"/>	<input type="checkbox"/>	<input type="checkbox"/>	<input type="checkbox"/>	<input type="checkbox"/>
Others, Please specify: _____	<input type="checkbox"/>	<input type="checkbox"/>	<input type="checkbox"/>	<input type="checkbox"/>	<input type="checkbox"/>	<input type="checkbox"/>

Comments:

* NIA: No Information Available

Environmental aspects	Low			High	NIA*
Energy consumption (Energy labelling: Class A, B, ...)	<input type="checkbox"/>	<input type="checkbox"/>	<input type="checkbox"/>	<input type="checkbox"/>	<input type="checkbox"/>
Power saving functions	<input type="checkbox"/>	<input type="checkbox"/>	<input type="checkbox"/>	<input type="checkbox"/>	<input type="checkbox"/>
Use of recycled materials	<input type="checkbox"/>	<input type="checkbox"/>	<input type="checkbox"/>	<input type="checkbox"/>	<input type="checkbox"/>
Emissions	<input type="checkbox"/>	<input type="checkbox"/>	<input type="checkbox"/>	<input type="checkbox"/>	<input type="checkbox"/>
Proven longer life cycle	<input type="checkbox"/>	<input type="checkbox"/>	<input type="checkbox"/>	<input type="checkbox"/>	<input type="checkbox"/>
Reuse and recycling options /	<input type="checkbox"/>	<input type="checkbox"/>	<input type="checkbox"/>	<input type="checkbox"/>	<input type="checkbox"/>
Recycling rate (%)	<input type="checkbox"/>	<input type="checkbox"/>	<input type="checkbox"/>	<input type="checkbox"/>	<input type="checkbox"/>
Others Please specify: _____	<input type="checkbox"/>	<input type="checkbox"/>	<input type="checkbox"/>	<input type="checkbox"/>	<input type="checkbox"/>

Comments:

* NIA: No Information Available

Which information channels do consumers preferably use to inform themselves about environmental features?

Information channels	Low			High	NIA*
Point of sale	<input type="checkbox"/>	<input type="checkbox"/>	<input type="checkbox"/>	<input type="checkbox"/>	<input type="checkbox"/>
User manual	<input type="checkbox"/>	<input type="checkbox"/>	<input type="checkbox"/>	<input type="checkbox"/>	<input type="checkbox"/>
Information hotlines	<input type="checkbox"/>	<input type="checkbox"/>	<input type="checkbox"/>	<input type="checkbox"/>	<input type="checkbox"/>
Your company website	<input type="checkbox"/>	<input type="checkbox"/>	<input type="checkbox"/>	<input type="checkbox"/>	<input type="checkbox"/>
On the Internet	<input type="checkbox"/>	<input type="checkbox"/>	<input type="checkbox"/>	<input type="checkbox"/>	<input type="checkbox"/>
Independent test magazines	<input type="checkbox"/>	<input type="checkbox"/>	<input type="checkbox"/>	<input type="checkbox"/>	<input type="checkbox"/>
Others, Please specify: _____	<input type="checkbox"/>	<input type="checkbox"/>	<input type="checkbox"/>	<input type="checkbox"/>	<input type="checkbox"/>

Comments:

* NIA: No Information Available

Do you see any relationship between environmental features of products and their market success, for example for eco-labelled products (if relevant)?

Yes No

If Yes, Please specify your experiences, positive and negative ones:

Consumers' usage behaviour

What information do you have on the "real life" usage of your appliances?

The answer will depend on the area (country) where the laundry dryer is used because of the difference in the habits and the climate and when it is used (season). Please specify this in your answer if it is relevant.

Do you consider different geographical areas (e.g. cold, moderate, and warm climatic zone)? If yes, with areas do you distinguish (and which countries do you include)?

Number of drying cycles per week per household (cycles/week)

Average duration of use (hours per day):

▪ On mode (use): _____

- Standby mode (if relevant): _____
 - Off mode: _____
- Please specify (country and/ or season): _____

Average life time (years):

→ Please specify (country and/ or season): _____

Average load of the dryer (kg):

→ Please specify (country and/ or season): _____

Location of the dryer: (outside, heated room such as the heated cellar, ...)

→ Please specify (country and/ or season): _____

Type of use:

- dryer for only one family (e.g. *the case in France*) (%):

- dryer shared by several families in an apartment building (e.g. *the case in Switzerland or in Nordic countries*) (%):

- other situation (specify) (%): _____

→ Please specify (country and/ or season): _____

Type of drying programme available and frequency of use:

Programme	Use rate (%)	Operating time (min)

Number of dryers with a start time delay option (%):

→ Please specify (country and/ or season): _____

Frequency of use of the start time delay option (% of drying cycles)

→ Please specify (country and/ or season): _____

Number of dryers with “reduced ironing” option (with a gentle rotating action to keep laundry free and fluffy) (%):

Use of “consumables” (for example: wipe for a sweet flavour):

Rate of change of the lint filter by the consumer? (at each cycle as required ?) ?

Other relevant information (please specify):

Additional Questions Concerning Consumers' Buying Decision and Behaviour

We do not expect you to have an answer to all the following questions, but every answer – even if it is a “no” – helps us to come to more concrete information concerning the consumers' behaviour.

Are you aware of how different lifestyles influence the buying decision or the usage pattern regarding environmental aspects?

Yes No

If Yes, Please specify:

Are you aware of any differences in buying decisions or consumer behaviour between the different countries of EU15, EU25 or EU27?

Yes No

If Yes, Please specify:

Do the recommended conditions of use for appliances differ from the testing conditions?

Yes No

Please comment your answer (difference for the load, for the location, ...):

Have you identified differences between real use conditions and instructions for use or design specifications?

Yes No

Please explain if such differences are country dependent or depend on the type of use

Local Infrastructure: Do you have any information on whether local infrastructure has an influence on consumer behaviour?

The availability and nature of the energy (electricity or gas for example):

Yes No

If Yes, Please specify:

The reliability of the electric grid:

Yes No

If Yes, Please specify: _____

The availability of special tariffs (night, ...):

Yes No

If Yes, Please specify:

The physical environment (such as the possibilities for shared laundry rooms, ...):

Yes No

If Yes, Please specify:

End-of-Life of appliances:

Do you have any information on the second-hand-market?
 (Do customers consider buying second hand products; does your company offer second hand products to customers; how do you judge the relevance of second-hand-markets in the different countries of EU15, EU25 or EU27?)

Yes No

If Yes, Please specify: _____

Do you have information about repair and maintenance practices, in particular potential of access to spare parts, and price?

Yes No

If Yes, Please specify: _____

Are there solutions in place for collection and take-back of laundry dryers at the end of their life?

Yes No

If Yes, Please specify: _____

Further comments concerning consumers buying decision or real life use?

Information impacting on consumer behaviour:

Direct information:

How is the consumer informed about environmental features of your products?

	Advertisement	Point of sale	Sales people	Packaging	User manual	Telephone hotline	Company website	Company report	Product sheet	Others:
Ecolabels (if any)	<input type="checkbox"/>	<input type="checkbox"/>	<input type="checkbox"/>	<input type="checkbox"/>	<input type="checkbox"/>	<input type="checkbox"/>	<input type="checkbox"/>	<input type="checkbox"/>	<input type="checkbox"/>	<input type="checkbox"/>
Energy class (energy labelling)	<input type="checkbox"/>	<input type="checkbox"/>	<input type="checkbox"/>	<input type="checkbox"/>	<input type="checkbox"/>	<input type="checkbox"/>	<input type="checkbox"/>	<input type="checkbox"/>	<input type="checkbox"/>	<input type="checkbox"/>
Energy consumption (for ex. during on-mode, standby, off-mode)	<input type="checkbox"/>	<input type="checkbox"/>	<input type="checkbox"/>	<input type="checkbox"/>	<input type="checkbox"/>	<input type="checkbox"/>	<input type="checkbox"/>	<input type="checkbox"/>	<input type="checkbox"/>	<input type="checkbox"/>
Energy optimised presetting	<input type="checkbox"/>	<input type="checkbox"/>	<input type="checkbox"/>	<input type="checkbox"/>	<input type="checkbox"/>	<input type="checkbox"/>	<input type="checkbox"/>	<input type="checkbox"/>	<input type="checkbox"/>	<input type="checkbox"/>
Energy saving potentials	<input type="checkbox"/>	<input type="checkbox"/>	<input type="checkbox"/>	<input type="checkbox"/>	<input type="checkbox"/>	<input type="checkbox"/>	<input type="checkbox"/>	<input type="checkbox"/>	<input type="checkbox"/>	<input type="checkbox"/>
Hazardous substances	<input type="checkbox"/>	<input type="checkbox"/>	<input type="checkbox"/>	<input type="checkbox"/>	<input type="checkbox"/>	<input type="checkbox"/>	<input type="checkbox"/>	<input type="checkbox"/>	<input type="checkbox"/>	<input type="checkbox"/>
Life time	<input type="checkbox"/>	<input type="checkbox"/>	<input type="checkbox"/>	<input type="checkbox"/>	<input type="checkbox"/>	<input type="checkbox"/>	<input type="checkbox"/>	<input type="checkbox"/>	<input type="checkbox"/>	<input type="checkbox"/>
Ease of upgrade and repair	<input type="checkbox"/>	<input type="checkbox"/>	<input type="checkbox"/>	<input type="checkbox"/>	<input type="checkbox"/>	<input type="checkbox"/>	<input type="checkbox"/>	<input type="checkbox"/>	<input type="checkbox"/>	<input type="checkbox"/>
Recycling options	<input type="checkbox"/>	<input type="checkbox"/>	<input type="checkbox"/>	<input type="checkbox"/>	<input type="checkbox"/>	<input type="checkbox"/>	<input type="checkbox"/>	<input type="checkbox"/>	<input type="checkbox"/>	<input type="checkbox"/>
Others: (Specify: _____)	<input type="checkbox"/>	<input type="checkbox"/>	<input type="checkbox"/>	<input type="checkbox"/>	<input type="checkbox"/>	<input type="checkbox"/>	<input type="checkbox"/>	<input type="checkbox"/>	<input type="checkbox"/>	<input type="checkbox"/>

Information for sales people

How do you provide the sales people with environmental information related to your product?

Please rate between 0 (=not at all) and (3)=intensively.

	Not at all (0)	(1)	(2)	Intensively (3)
Part of general training for sales people	<input type="checkbox"/>	<input type="checkbox"/>	<input type="checkbox"/>	<input type="checkbox"/>
Special trainings on environmental topics	<input type="checkbox"/>	<input type="checkbox"/>	<input type="checkbox"/>	<input type="checkbox"/>
Product sheets	<input type="checkbox"/>	<input type="checkbox"/>	<input type="checkbox"/>	<input type="checkbox"/>
Additional information on environmental topics	<input type="checkbox"/>	<input type="checkbox"/>	<input type="checkbox"/>	<input type="checkbox"/>
Others	<input type="checkbox"/>	<input type="checkbox"/>	<input type="checkbox"/>	<input type="checkbox"/>
Please specify: _____	<input type="checkbox"/>	<input type="checkbox"/>	<input type="checkbox"/>	<input type="checkbox"/>
Comments:				

Additional questions

Here are some subsidiary questions concerning the information provided to consumers.

Do environmental aspects play a significant role in your marketing strategy when launching a new product on the market?

Yes No

If Yes, Please specify: _____

In the context of increasing oil-prices and energy prices, and scarcity of resources, do you plan to set a stronger focus on energy-efficiency and environmental performance?

Yes No

If Yes, Please specify: _____

Are there any differences in your marketing activities concerning environmental aspects between the countries of EU27?

Yes No

If Yes, Please specify: _____

What could your company do / what is your company planning to do: to optimise users' behaviour regarding environmental aspects?

IV Task 4: Technical analysis of existing products

IV.1 Objective and methodology

Task 4 is dedicated to the technical analysis of existing products on the EU-market. Bills of materials (BOM) and resources consumption data during product life have been compiled for selected products. Following the VHK methodology these data will provide the general input for the definition of the Base Cases in Task 5.

In view of Task 5, products were selected for the analysis according to the following specifications:

- Products of different drying technologies
- Products that represent strong market segments
- Products with expected technical improvement potential

With these aspects in mind, a request was addressed to manufacturers at the beginning of the study to provide particular data for products satisfying such criteria.

Based on the results of the market analysis (Task 2), we selected two primary product cases:

- Air vented tumble dryers
- Air condenser tumble dryers (or simply condenser tumble dryers)

The following paragraph discusses the data inputs for their technical analysis.

Heat pump dyers and gas dryers are also available on the market, but they do not represent a strong segment of the market yet and will be considered as best available technologies in this study. Thus, the technical description of these two types of dryers will be performed in task 6.

Available data from product cases for Technical Analysis

Data from a total of 14 models of laundry dryers were provided by individual companies. It should be stressed that all product data were provided by 7 brand-name manufacturers:

- Bosch und Siemens Haushaltgeräte (BSH)
- CROSSLEE
- FAGORBRANDT
- ELECTROLUX
- INDESIT
- MIELE
- WHIRLPOOL

IV.2 Production phase

This section presents an analysis of the mechanism of each tumble dryer type. This description explains the function of the different components of a tumble dryer and will be completed with an average bill of material for each technology.

IV.2.1 Air vented tumble dryers



Figure 81: Picture of an air vented tumble dryer (Front)³²

Two types of laundry loading are possible: Top or Front loading. According to the market analysis and the consumer behaviour study, the front version is the most commonly used. In the following sections, which concern the description of the components, the focus will be on front models. A specific paragraph will be dedicated to top models in a sensitivity analysis.

Technical description

As shown on Figure 82, this type of laundry dryers operates in open circuit. Ambient air comes in from the surrounding environment thanks to openings in the metal structure. Ambient air is heated with a heating element and blown into the drum where the drying process occurs. Once the warm air is charged with the laundry moisture, it is evacuated outside through a flexible pipe.

During the whole drying process, the drum is set into rotation by the motor in order to spread the load in the whole available volume.

To install that type of machine, it is necessary to have a room with two openings to the outside, the first one to vent to the outside and the second one to intake the fresh air. If there is no vent to the outside, extra care for ventilation is necessary to prevent condensation in the room.

³² Source: Miele

The air vented dryer is mainly composed of³³:

- A drum
- A motor
- An air circuit constituted of: a fan, an heating element at the inlet of the drum, an air filter at the outlet of the drum.
- A cabinet
- A control system

The main components of the air vented tumble dryer are presented below:

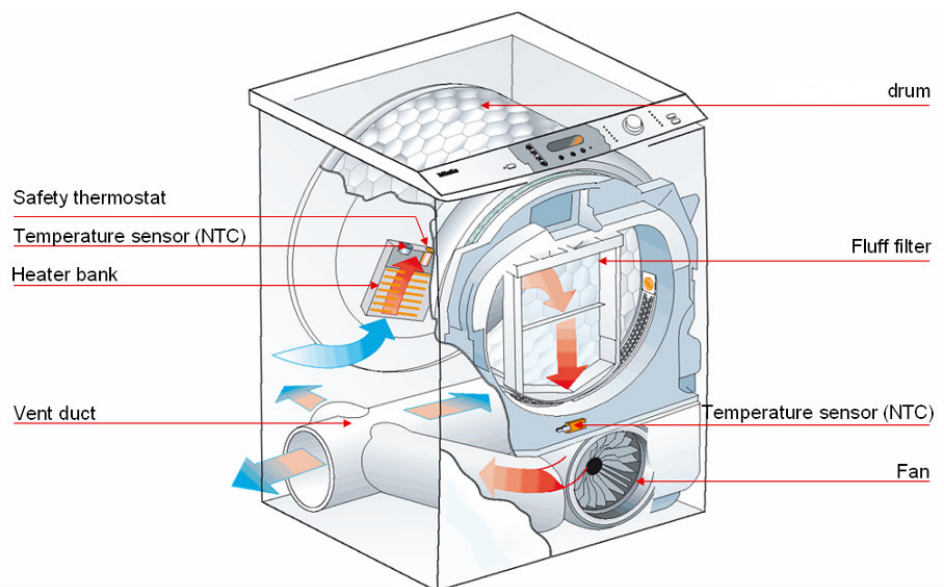

Figure 82: Air vented tumble dryer (Front) – Components and function³⁴

Drum



Figure 83: Drum of an air vented dryer (Front)³⁵

³³ Source : Palandre (2005), *Evaluation of high energy efficiency technical solutions for domestic dryers – Conception and modelling of a highly humid air mechanical compression dryer*

³⁴ Source: Miele

³⁵ Source : Bauknecht



Figure 84: Drum of an air vented dryer (Front)³⁶

Two different drum technologies exist:

- The first one (the most common) is made of one rotating piece (also common for condenser tumble dryers).
- The second one consists of a drum divided into two parts: one mobile and one fixed; this drum type requires a specific rotation system (see Figure 83)

The volume of dryer drums is twice as big as that of washers. In fact, the drying efficiency towards the end of the cycle, when a little residual humidity remains, depends a lot on the ratio linen mass/drum volume. The linen will also be smoothed out more easily when the volume of the drum is large.

In most cases, drums are made of galvanized steel for low cost dryers or stainless steel for higher cost dryers. But drums do exist in zinc.

Two different seals, positioned at the inlet and the outlet of the drum, ensure tightness against the external environment.

Motor and blower

Only one motor provides the rotation of the drum and the blower: the provision of mechanical and thermal energy is thus coupled.

The drum rotates both ways to improve the tossing and prevent linen entanglement.



Figure 85: Motor and fan³⁷

Concerning the motor, its power consumption can be considered in a range of 150 W to 250 W.

³⁶ Sources: Electrolux (left) / Crosslee (right)

³⁷ Source: Crosslee

Concerning the blower, the air flow varies from 100 m³/h to 240 m³/h with an average around 120 m³/h. In order to obtain this range of flows, only one technology of blower can be used: the centrifugal fan. Well known under the name of "squirrel cage", the centrifugal fan has a moving component (called an impeller) that consists in a central shaft about which a set of blades, or ribs, are positioned. Centrifugal fans blow air at right angles to the intake of the fan, and spin the air outwards to the outlet (by deflection and centrifugal force). The impeller rotates, causing air to enter the fan near the shaft and move perpendicularly from the shaft to the opening in the scroll-shaped fan casing. A centrifugal fan produces more pressure for a given air volume. The main drawback is that they are typically noisier than comparable axial fans.

It is important for calculation to know the airflow when the exhaust is attached to the appliance. For calculation of the correction factor with the new standard EN 61121:2005, it should be in the range 90-100 m³/h with a standard duct connected to the appliance.

Heating element

In order to carry out an efficient drying, the ambient air must be heated up to a temperature of 70-100°C in normal conditions, using electricity. Depending on the design, the temperature may vary to a great extent.

Consequently, air is introduced into the drum through a pipe where the heating element is located. This heating element is mounted as close to the drum as possible in order to minimize thermal losses.



Figure 86: Sheathed element heater³⁸

The main common technologies (also used in condenser dryers) are the following ones:

- Sheathed element heater (Figure 86): similar to heating element used in washing machines. This type of heating element has a high thermal mass: indeed, the sheath retains heats when the element is switched off.
- Open coil heating elements (Figure 87). This type of heating element consists in resistive coils which are isolated from the metallic structure. In order to maximize the energy transfer between coils and air, the transfer surface must be as large as possible, that is why the filament is coiled.

³⁸ Source: Crosslee

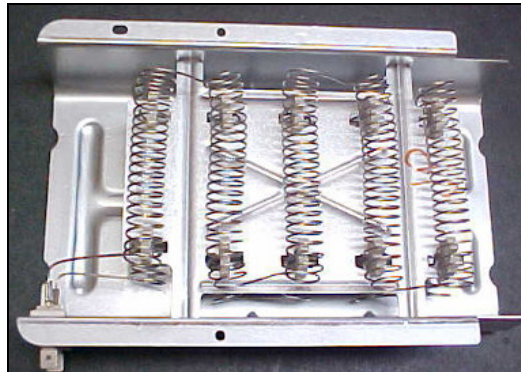

Figure 87: Open coils heating element³⁹

The advantages of the open coil technology are as followed:

- low cost
- very low thermal inertia

The heating element can be equipped with two types of safety system: one controlling overheating and the other one limiting over current.

Fluff filter or air filter

The degradation of fabrics is due to linen being worn out but also to the attack of washing powder agents, and to mechanical constraints during the washing and spin-drying cycles. This degradation results in the coming off of superficial fibres, which will yet remain attached to the fabric as long as the linen is damp. In the drying cycle, the linen will be tossed in the drum, so that it becomes suppler and takes up more space. The air circulation associated with the moving of the linen will remove the worn out fibres which will be carried out of the drum in the circuit.



Figure 88: Single flat surface filter⁴⁰

Filtrating air coming out of the drum is necessary to stop all the fibres that come off of the linen. The absence of a filter would cause the gradual clogging up of the pipes and thereby alter the performance of the fan. The filtering surface must be wide enough to be efficient and not cause too much pressure loss. However for an air venting dryer, which operates in open circuit, the filtration efficiency is a far less critical issue than for condensation models that operate in closed circuit.

Air filters are currently composed of a frame in polypropylene and a mesh in nylon.

³⁹ Source: Crosslee

⁴⁰ Source: Crosslee

Different types of filters are available; they can generally be distinguished by the number of filter layers:

- Filters with one filter level: it can be a simple single flat surface filter (See Figure 88) or a V-shaped Filter, which allows a larger filter area with a smaller overall dimension.
- Filters with two filter levels: this second type is often designated as a hinged v-shaped filter

It is important to notice that the efficiency of a filter depends on the mesh width and on the type of weave.

End of cycle control

An important feature in tumble dryers is the ability of the drying process to be stopped as soon as the moisture content of the load has been brought down to the desired value. In fact, if the drying process is interrupted too early, the resulting moisture content would be too high and this would entail disadvantages.

On the other hand, interrupting a drying process too late leads to an unnecessarily high energy usage. Besides, very low moisture content reduces “ironability” and damages the load.

Consequently, controlling the drying cycle requires accurate measure of the linen humidity along the cycle.

Two end of cycle control strategies have been identified:

- Time control: The cycle is stopped after a given time, pre-selected by the user, either using a mechanical or an electronical control. No humidity control is carried out (see 92).



Figure 89: Time control⁴¹

- Automatic control:
 - Indirect way: The method consists in measuring the relative humidity at the drum outlet thanks to a moisture sensor. The drying process stops, when the moisture content reaches a pre-established value. But this type of measure is not totally reliable, when the drum is lightly loaded⁴².
 - Direct way: There is a direct relation between the electrical resistance of linen and its relative humidity. Indeed, the laundry resistance increases when the moisture level decreases. Therefore, of the resistance of the load is measured between the sensing rods mounted on the drum lifters and the earthed drum body. The measure is actually taken at the lower outlet of the drum, at the filter,

⁴¹ Source : Gorenje

⁴² Source : Palandre (2005) *Evaluation of high energy efficiency technical solutions for domestic dryers – Conception and modelling of a highly humid air mechanical compression dryer*

by two metallic blades onto which a difference in electrical potential is applied. The linen in the drum hits these terminals which produces a feeble electric current. That electric signal will then be interpreted into the programming of the drying cycle (see Figure 90).

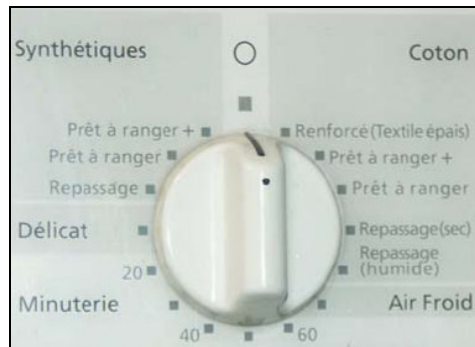

Figure 90: Cycle programmer⁴³

One typical way of automatic control is the following one: the resistance is sampled via a carbon brush on a slip ring and an averaging circuit monitors the resistance levels of the clothes as they dry. (See Figure 91 and Figure 92).



Figure 91: Linen conductivity sensor⁴⁴



Figure 92: Carbon brush

For types of basic dryers, only a time control is operated.

⁴³ See Note 15

⁴⁴ Source: Crosslee for the figures presented in this page

User Interface

The types of control available to the users range from simple rotary knobs for programme selection with a visual indicator signalling the end of the drying cycle to LCD-equipped menu-driven interfaces, as illustrated on the following Figure s

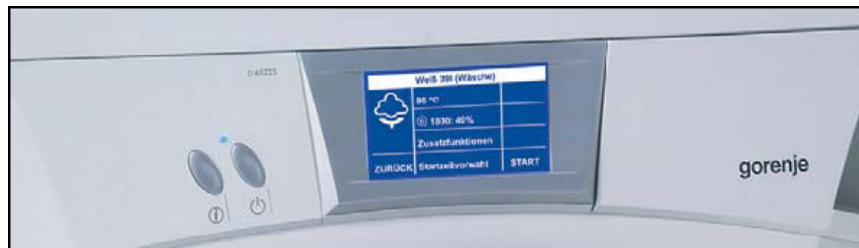

Figure 93: User interface with touch screen



Figure 94: User interface with LCD display panel⁴⁵

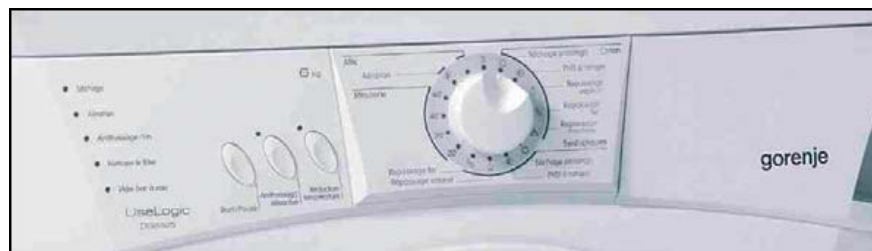

Figure 95: User interface with LED



Figure 96: User interface with simple time control (mono-command)

⁴⁵ Source: Gorenje for the figures presented in this page

Bill of Materials

The data regarding the composition of air vented tumble dryers have been collected for 6 models. The average data are presented in the following sections.

Characteristics of a typical air vented tumble dryer:

According to the choice of models for the base cases (see task 5), here are the average principal characteristics of an air vented tumble dryer:

Table 40: Average characteristics of an air vented tumble dryer

Size	Width:60 cm Height: 85 cm Depth: 54 cm
Weight	Average: 34 kg ⁴⁶ (range: 31- 45 kg)
Machine type	Free standing or built-in
Capacity	6 kg
Loading type	Front
Energy rating	C
Noise level	62-69 dBA
Control	Automatic (Moisture controlled)
Possible features*	
Reverse action	
Anti crease function	
LED display	
Final cool tumble action	
Possible indicators*	
Filter care indicator	
Remaining time indicator	
Warning LED indicator	
Acoustical indicator	
End of program indicator	

* Features and indicators can be proposed by manufacturers on each type of laundry dryer.

Material composition

Regarding the composition in terms of materials (metals / plastics / other), the average composition of an air vented tumble dryer is presented in the

. This average composition was calculated with a simple arithmetic average. Consequently, this BOM is not representative of a real tumble dryer model. That is also why the ranges for the values provided by manufacturers are presented. Now, it should be considered as a first approach which allows to identify the most impacting life cycle phases and the most impacting types of materials. The relevance of such an approach will be checked in Task 5.

⁴⁶ This value is the result of an arithmetic average of the manufacturers' BOM

Table 41: Average material composition of an air vented tumble dryer (1)

Material / Components	Weight (g)	Weight ratio (%)
Metals		
Ferrous metals	22 578	65
Steel	12 186	[range:14 -100] ⁴⁷
Galvanized sheet steel	2 856	[range:0 -24] ⁴⁸
Painted sheet steel	3 760	[range:0 -56] ⁴⁹
Stainless steel	3 776	[range:0 -46] ⁵⁰
Copper	231.2	1
Aluminium	610.6	2
Plastics		
Polypropylene (PP)	4 157.0	12
Polystyrene	364.5	1
Acrylonitrile Butadiene Styrene (ABS)	1306.8	4
Polyamide (PA)	98.7	0
Polyoxymethylene (POM)	29.4	0
Polymethylmetacrylate (PMMA)	29.7	0
Polycarbonate (PC)	3.8	0
Polyvinyl chloride (PVC)	99.8	0
Other plastics	1 336.7	4
Electronic components	1 556.0	5
Others	17 778.4	5
Total	34 377 [range: 28.9-45.9 kg]	100

Regarding the material distribution type coming from the VHK model, the composition of an air vented tumble dryer is:

Table 42: Average material composition of an air vented tumble dryer (2)

Life Cycle phases -->	PRODUCTION			
	Resources Use and Emissions	Material	Manuf.	Total
Materials	unit			
Bulk Plastics	g			4625
TecPlastics	g			3000
Ferro	g			22516
Non-ferro	g			842
Coating	g			0
Electronics	g			1556
Misc.	g			1778
Total weight	g			34317

It comes that around 65% of the weight of an air vented tumble dryer is made of ferrous metals. Regarding the plastic parts, the most commonly used plastic is polypropylene (12% of the dryers' weight).

⁴⁷ Percentage of ferrous metal part : range of values

⁴⁸ Percentage of ferrous metal part : range of values

⁴⁹ Percentage of ferrous metal part : range of values

⁵⁰ Percentage of ferrous metal part : range of values

Specific case: a “compact” air vented tumble dryer

There is a special type of air vented dryers on the market, especially appropriate for households in small flats where there is no space for a standard laundry dryer for example (see Task 3): some brands manufacture and sell compact dryers. This section briefly describes the characteristics and the composition of such laundry dryers.

Note:

- There is no compact dryer B class on the market, only C end D class. The chosen compact dryer is a D class.
- There is no compact dryer equipped with an automatic control (moisture). The chosen compact dryer is equipped with a timer control.

Here are some pictures of elements of a compact dryer:



Figure 97: Drum of a compact tumble dryer⁵¹



Figure 98: Motor and fan of a compact tumble dryer

The main characteristics of a compact dryer are:

Table 43: Average characteristics of a compact air vented tumble dryer

Size	Width: 50 cm Height: 67 cm Depth: 47 cm
Weight	23 kg
Machine type	Free standing or built-in
Capacity	3 kg
Loading type	Front
Energy rating	D
Noise level	61 dBA
Control	Timer

⁵¹ Source: Crosslee for the figures presented in this page

Regarding the composition in terms of materials (metals / plastics / other), the average composition of a compact air vented tumble dryer is as follows (model VHK):

Table 44: Average material composition of a compact air vented tumble dryer

Life Cycle phases -->		PRODUCTION		
Resources Use and Emissions		Material	Manuf.	Total
Materials		unit		
1	Bulk Plastics	g		1520
2	TecPlastics	g		417
3	Ferro	g		19540
4	Non-ferro	g		1375
5	Coating	g		6
6	Electronics	g		0
7	Misc.	g		233
Total weight		g		23091

There, it comes that around 85% of the weight of a compact dryer is in ferrous metals. This is more than for usual air vented dryers. Plastics account for around 8.5 % of the weight.

IV.2.2 Condenser tumble dryers

A condensation dryer passes heated air through the load. However, instead of exhausting this air, the dryer uses a heat exchanger to cool the air and condense the water vapor into either a drain pipe or a collection tank. Two types of condenser dryers can be found on the market: air condenser or water condenser dryers. The difference lies in the heat exchange process, the internal warm air being cooled either using ambient air (air condenser dryers) or cold water (water condenser dryers). Water condensation is most common for wash and dry machines, whereas the vast majority of tumble dryers currently available are air condenser models (so far, only one water condenser dryer model has been identified on the market for tumble dryers). We will therefore focus our technical description on this type of condenser dryers.



Figure 99: Pictures of an air condenser tumble dryer (Front)⁵²

⁵² Source: Miele

Technical description

An air condenser tumble dryer could be also designated as a closed circuit air dryer. The drying process in closed circuit requires two different air circuits.

The principle of the air condenser dryer is the following one:

- In the closed warm air circuit: the air is heated by an electrical heating element and blown into the drum where the drying process occurs. Once the warm air is charged with moisture (the relative humidity of the air is near 100%), it is driven through the condenser, where the warm air is at first cooled, then condensed. After being dried, this air is again heated by the heating element and blown in the drum. The water condensed during this process is either collected in a tank, or drained into a sink.
- In the cold air circuit: A cold air circuit is necessary in order to condensate the vapor contained in the warm air. Indeed, the condenser used in an air condenser dryer is an air-air condenser. According to the dryer model, it can be a crossed or a counterflow exchanger.

These dryers are slightly more expensive compared to air-vented tumble dryers (see Task 3), but they offer the versatility of not needing to be located next to an external wall, contrary to air-vented dryers. Also, any 'wasted' heat is lost to the home rather than being vented outside. This is a benefit on cold days but a drawback on hot days.

The main components of the air condenser tumble dryer are the following ones.

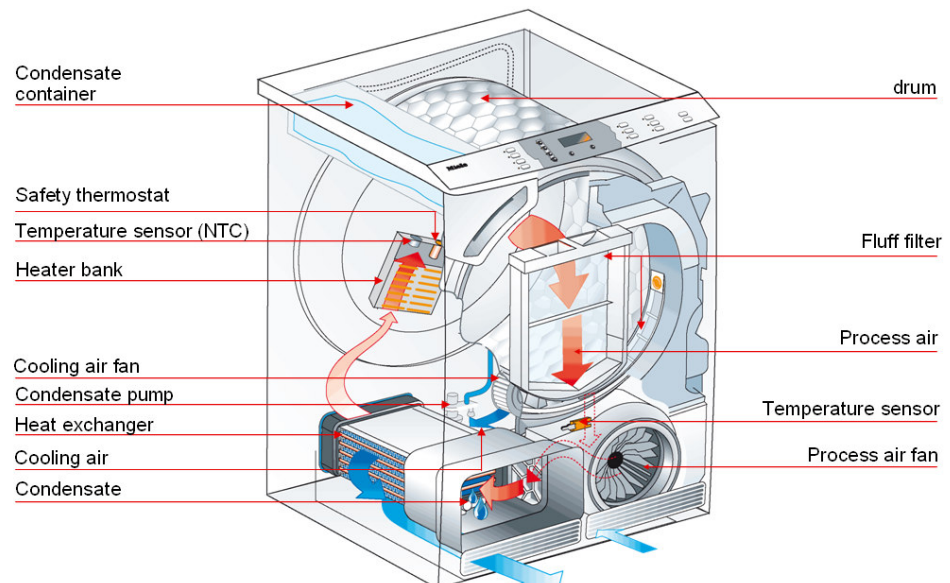

Figure 100: Air condenser tumble dryer – Components and function⁵³

Drum, filter, heating element, end of cycle control, user interface

Concerning drum, fluff filter, heating element end of cycle control and user interface, the most common technologies are relatively similar to those presented previously for air vented tumble dryers.

⁵³ Source: Miele

Motor and blowers

In an air condenser tumble dryer, two blowers are needed:

- one for the warm air circuit
- one for the cold air circuit



Figure 101: Condenser motor⁵⁴

Generally, both air blowers and drum are driven by the same motor, but, according to manufacturers, dryers with two motors (one for the drum and one for the blowers) can exist. The shifting rotation of the drum is necessary to limit linen entanglement but it forces the blowers to turn both ways alternatively.

In a condenser dryer, the location of the blower is very important. The heated air circuit needs to be placed downstream of the drum. As a result, the drum will be in depression. If a leak appears in the drum, the outside air will come inside.

Conversely, if the blower were placed upstream of the drum, the drum would be in excessive pressure

Heat exchanger or condenser

The most common condensers are air-air crossed flow condensers.

The condenser partly dehumidifies the air that comes out of the drum. It has to have the following characteristics:

- have a wide enough heat exchange area to carry out the condensation of the water vapor extracted from the linen, while taking into account the difference of heat exchange coefficients on the internal and external sides,
- allow the draining of condensates towards a low point,
- provide a heat exchange area that is little sensitive to the clogging up with fabrics fibres hanging in the air,
- be easily accessible and removable for cleaning by the user.

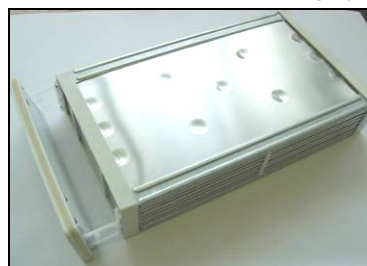

Figure 102: Heat exchanger⁵⁵

⁵⁴ Source: Crosslee

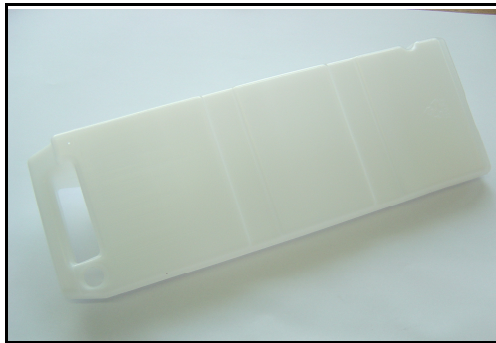

Figure 103: Condensate reservoir

The condensation efficiency can vary from 50% to 95% depending on the global air tightness of the system, and depends on the global quality and design of the dryer.

The condensate reservoir is removable and can store all the water that is extracted from the linen and condensed. It must be emptied after each cycle. A level sensor detects water level and warns the user.

The condensate reservoir can be filled thanks to a water pump. In this case, the condensate tank is located in the upper part of the condenser dryer.

Finally, there is the possibility to drain the water to the outside.

Fluff filter or air filter

As in air vented dryers, an air filtration is necessary in condenser dryers. These machines operate in closed systems and are sensitive to clogging.

In this type of dryer, only a filter with a double mesh: hinged V-shaped filter (See Figure 104) can be used.

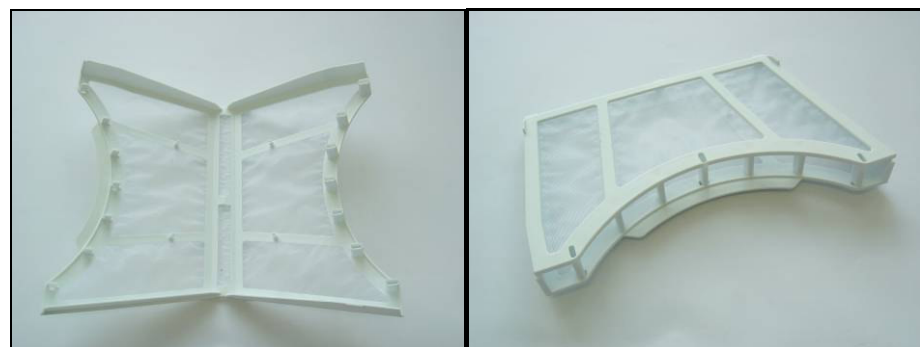

Open

Closed

Figure 104: Hinged V-shaped filter⁵⁶

⁵⁵ Source: Crosslee for the figures presented on this page

⁵⁶ Source: Crosslee

The filter plays a central part in the efficiency of the dryer. The accumulation of micro fibres of fabrics in the system may, in the long run, result in a deposit on the pipes. The condenser is the element most sensitive to this problem. In addition to the clogging up of the heat exchange area, a deposit of fibres at the heat exchanger inlet could appear which would block up the passage section. In these operating conditions, pressure losses would increase and the air flow rate would be reduced. Next, the accumulation of fibres on the condensate draining system might clog the drainage system.

The coming off and carrying away of the linen fabrics happen towards the end of the cycle, when the linen humidity is relatively low. The particles deposit on the first obstacles they meet, in the places where they have come to a stop. In case of considerable accumulation, they may be taken away; this would let fibre agglomerates into the air flux. The heating element may also become a place of blocking of these fabrics fibres. In the case of a non-electric insulated coil, the temperature could reach (>500°C) and damage the laundry. However, since the system is sealed and there is no air coming from the outside, there is no risk of fire.

Those unusual cases, although they result from a neglected use of the dryer, must be taken into account by the manufacturer into the design of the system.

To increase the filtration efficiency without hindering much the operation of the blower because of pressure losses, the filtration surface must be as large as possible. The filter must be easily removable and accessible by the user. The cleaning must be simple: the fabrics deposit should be removable manually.

Bill of Materials

The data regarding the composition of air condenser tumble dryers have been collected for 6 models. The average data are presented in the following sections.

Characteristics of a typical air condenser tumble dryer:

According to the choice of models for the base cases (see task 5), here are the average principal characteristics of an air condenser tumble dryer:

Table 45: Average characteristics of an air condenser tumble dryer

Size	Width:60 cm Height: 85 cm Depth: 54 cm
Weight	42 ⁵⁷ kg Range: 37-50 kg
Machine type	Free standing or built-in
Capacity	6 kg
Loading type	Front
Energy rating	C
Energy consumption (under standard conditions)	0.60 kWh / kg 3.60 kWh / cycle
Noise level	Range: 62-72 dBA
Control	Automatic (Moisture controlled)
Condensation efficiency	80%

⁵⁷ This value is the result of an arithmetic average of the manufacturers' BOM.

Material composition

Regarding the composition in terms of materials (metals / plastics / other), the average composition of an air condenser tumble dryer is presented in Table 5. As for air vented dryers, this average composition was calculated with a simple arithmetic average. Consequently, this BOM is not representative of a real tumble dryer model. The relevance of such an approach will be checked in task 5.

Table 46: Average material composition of an air condenser tumble dryer(1)

Material / Components	Weight (g)	Weight ratio (%)
Metals		
Ferrous metals	20 132	56
Steel	12 600	[range: 14-100]
Galvanized sheet steel	2 515	[range: 0-56]
Painted sheet steel	3 588	[range: 0-36]
Stainless steel	1 428	[range: 0-26]
Aluminium	653.5	2
Copper	710.3	2
Plastics		
Polypropylene (PP)	7 714.5	18
Acrylonitrile Butadiene Styrene (ABS)	2 117.0	5
Polystyrene (PS)	377.8	1
Ethylene Propylene Diene M-Class (EPDM Rubber)	330.3	1
Polyamide (PA)	197.6	0
Polyoxymethylene (POM)	85.7	0
Polymethylmethacrylate (PMMA)	28.3	0
Polycarbonate (PC)	23.3	0
Polyvinyl Chloride (PVC)	115.3	0
Other plastics	2 475.0	6
Electrical / Electronic components	1 987.7	5
Others	1 856.3	4
Total	42 159 [range: 35.9-50.2 kg]	100

Regarding the material distribution type coming from the VHK model, the composition of an air condenser tumble dryer is:

Table 47: Average material composition of an air condenser tumble dryer(2)

Life Cycle phases --> Resources Use and Emissions	unit	PRODUCTION		
		Material	Manuf.	Total
Materials	unit			
Bulk Plastics	g			12800
TecPlastics	g			679
Ferro	g			23473
Non-ferro	g			1364
Coating	g			0
Electronics	g			1988
Misc.	g			1856
Total weight	g			42159

It comes that around 56% of the weight of an air condenser tumble dryer is in ferrous metals. Regarding the plastic parts, the most commonly used plastic is polypropylene (18% of the dryers' weight).

Specific case: a “top loading” air condenser tumble dryer

As previously said, regarding the type of loading of laundry dryers, both top and front loading can be found on the market with a higher market share for the “front” products (around 80%; see Task 3).

For the choice of the base cases, it has been decided to choose the front type. Nevertheless a sensitivity analysis will be carried out to take account of the other type. This section deals with the characteristics and the composition of such dryers. One model of top loading air condenser tumble dryer has been studied.

Note: The chosen capacity of the base-cases is 6 kg but there is no to loading dryer with such capacity on the market. Therefore the capacity of the studied dryer is: 5 kg.

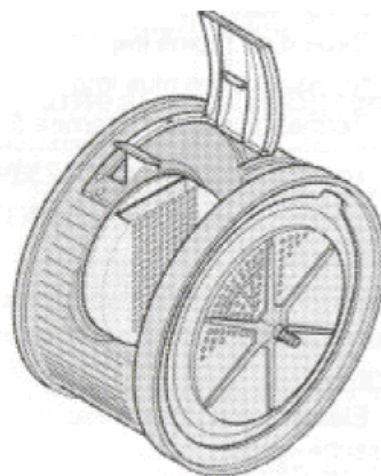

Figure 105: Drawing of the drum of a top loading condenser tumble dryer⁵⁸

⁵⁸ Source: Fagor-Brandt

The main characteristics of a top loading air condenser tumble dryer are:

Table 48: Characteristics of a top loading air condenser tumble dryer

Size	Width:45 cm Height: 85 cm Depth: 60 cm
Weight	37 kg
Machine type	Free standing or built-in
Capacity	5 kg
Loading type	Top
Energy rating	C
Energy consumption (<i>under standard conditions</i>)	0.7 kWh / kg 3.49 kWh / cycle
Noise level	66 dBA
Control	Automatic (Moisture controlled)
Condensation efficiency	81%

Regarding the composition in terms of materials (metals / plastics / other), the average composition of a top loading air condenser tumble dryer is as follows:

Table 49: Material composition of a top loading air condenser tumble dryer (1)

Material / Components	Weight ratio (%)
Metals	
Painted sheet steel	24
Galvanized sheet steel	19
Steel	11
Stainless steel	9
Aluminium	4
Copper	3
Plastics	
Polypropylene (PP)	19
Polyamide (PA)	3
Polystyrene (PS)	2
Acrylonitrile Butadiene Styrene (ABS)	1
Other plastics	2
Electrical / Electronic components	3
Total	100

Regarding the material distribution type coming from the VHK model, the composition of the top loading dryer is:

Table 50: Material composition of a top loading air condenser tumble dryer (2)

Life Cycle phases -->		PRODUCTION		
Resources Use and Emissions		Material	Manuf.	Total
	Materials			
	unit			
1	Bulk Plastics	g		8910
2	TecPlastics	g		1220
3	Ferro	g		23360
4	Non-ferro	g		2280
5	Coating	g		0
6	Electronics	g		1210
7	Misc.	g		0
	Total weight	g		36980

It comes that around 63% of the weight of a top loading condenser tumble dryer is in ferrous metals. Regarding the plastic parts, the most commonly used plastic is polypropylene (19% of the dryers' weight).

IV.3 Distribution phase

Tumble dryers can be packed in “canopy” wood protection with cardboard and also expandable polystyrene material (EPS) at each edge line to ensure maximum protection of sensitive parts. Most of the time, they sit on a wood base and are surrounded by a plastic PE foil. It is important to note that this type of package is not the most common.

Concerning the inferred transport, after exchanges with industrial sources, a distance of 1000km was considered, this distance being notably due to the fact that there are few factories of tumble dryers in Europe.

Figure 106: Type of packaging of a laundry dryer⁵⁹



Depending on the model of laundry dryer considered, the weight and the volume of the packaged product are as follows:

	Air-vented tumble dryer	Air condenser tumble dryer	Compact air-vented tumble dryer	Top air condenser tumble dryer
Weight	From 1.27 to 4,6 kg	From 1.27 to 4.6 kg	1 kg	1.35 kg
Volume	From 0.34 to 0.41 m ³	From 0.34 to 0.41 m ³	0.208 m ³	0.346

⁵⁹ Source: Miele

IV.4 Use phase (Product)

IV.4.1 Key aspects of the drying process

The drying process consists in removing the water from a product. In the case of laundry dryers, water is extracted from the laundry:

- Mechanically: In its liquid form, water can be extracted thanks to the gravity force. This drying efficiency is improved by spinning and making use of centrifugation forces. The major inconvenient concerning this drying process is the fact that only a part of water is extracted: the final moisture level remains important.
- Thermally: A sufficient amount of energy is needed to make water evaporate and to evacuate the residual steam. All the water contained in the laundry can be extracted but this drying process requires more energy than the mechanical drying process.

Some key definitions

- Moist air or humid air: Gaseous mixture of water vapour and dry air. Its physical properties depend on: temperature, pressure and one other mix characteristic parameter.
- Dry bulb temperature: The temperature obtained by a regular thermometer, which shows the sensible heat in the air
- Mixing ratio: in humid air, the mass of water vapour per unit mass of dry air

$$r = \frac{m_{\text{vapour}}}{m_{\text{dryair}}}$$

- Relative humidity (RH): Ratio expressed as a percentage of the water vapour actual pressure to the saturated vapour pressure at the same dry bulb temperature.

Water vaporization

Water vaporization is key to the drying process in a laundry dryer. When the load is dried, air is used as the drying medium. Air normally contains a certain amount of water vapour. So drying a wet material will result in humidification of the air. Water is transferred from the liquid phase into the humid air. The theoretical possible water content of the air is limited: the maximum amount of water vapour in the air depends on temperature and vapour pressure. Water can be removed by evaporation or vaporization. To evaporate the liquid, the temperature of the moisture must be raised to the boiling point. During drying in air, water is transferred from liquid to vapour by vaporization.

Two parameters affect the drying rate⁶⁰:

- Humidity
- Temperature

It is important to notice that the humidity can be described as specific humidity r or as relative humidity Φ .

The specific humidity (r) or absolute humidity is the mass of water vapour in a given volume of air:

$$r = \frac{m_{\text{vapour}}}{m_{\text{dryair}}} \quad (1)$$

Where,

m_{vapor} is the mass of water vapour

$m_{\text{dry air}}$ is the mass of dry air

Dry air and water vapour are both considered as ideal gases, so

$$r = \frac{M_{\text{vapour}} \cdot p_{\text{vapour}}}{M_{\text{dryair}} \cdot P_{\text{dryair}}} \quad (2)$$

Where:

M_{vapor} is the molar mass of water vapour = 18,01 kg/mol

$M_{\text{dry air}}$ is the molar mass of dry air = 28.96 kg/mol

p_{vapor} is the partial pressure of water vapour

$p_{\text{dry air}}$ is the partial pressure of dry air

$$r = 0.622 \cdot \frac{P_{\text{vapour}}}{P_{\text{dryair}}} \quad (3)$$

The relative humidity (Φ) is the amount of water vapour in the air compared with the amount of vapour needed to saturate the air at current temperature:

$$\phi = \frac{P_v}{P_v^0} \quad (4)$$

Where:

P_v is the partial pressure of water vapour

P_v^0 is the saturated vapour pressure at the same pressure

By a combination of the two equations (3) + (4), we obtain:

$$r = 0.622 \frac{\phi P_v^0}{P - \phi P_v^0} \quad (5)$$

Where:

$$P = P_{\text{vapour}} + P_{\text{dryair}}$$

⁶⁰ Source : Fagor-Brandt and Brunsell (2004),

Under standard conditions (20 °C), the relative humidity of 65% means an absolute humidity of 9,45g per kg air.

If the relative humidity is lowered, the ability of the air to absorb water vapour increases. This can be achieved by increasing the temperature of the air. That is why the air is heated by a resistance before going through the tumble. The specific humidity as well as the relative humidity will increase when the air passes over the wet clothes.

In order to evaluate the energy gains and losses during the transformation of the humid air mixture during the drying process, the enthalpy could be a good indicator.

The enthalpy of humid air is calculated as following:

$$H = H_{dryair} + r.H_{vapour} \quad (6)$$

Where:

H_{dryair} is the dry air enthalpy

H_{vapour} is the vapour enthalpy

For the dry air, enthalpy is defined as:

$$H_{dryair} = C_{pA} T \quad (7)$$

Where C_{pA} is the specific heat capacity.

The dry air is considered as an ideal gas so C_{pA} is constant, as well as C_{pV} .

Where C_{pV} is the specific heat capacity of water vapor

For the water vapor:

$$H_{vapour} = C_{pV} T + \Delta H_{vapour} \quad (8)$$

Where:

ΔH_{vapour} is the latent heat and is 2501.3 kJ/kg.

To conclude:

$$H = C_{pA} T + r(C_{pV} T + \Delta H_{vapour}) \quad (9)$$

The equation (9) allows following the drying process in an enthalpy-humidity chart (see Figure 107) which shows the relation between temperature, enthalpy and water content, r . It actually presents the theoretical relation between dry temperature, enthalpy and water content at the atmospheric pressure.

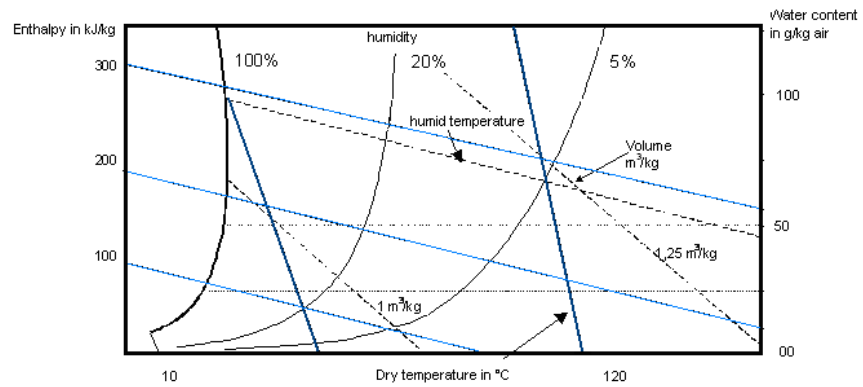

Figure 107 Abacus⁶¹

Application to the air vented tumble dryer

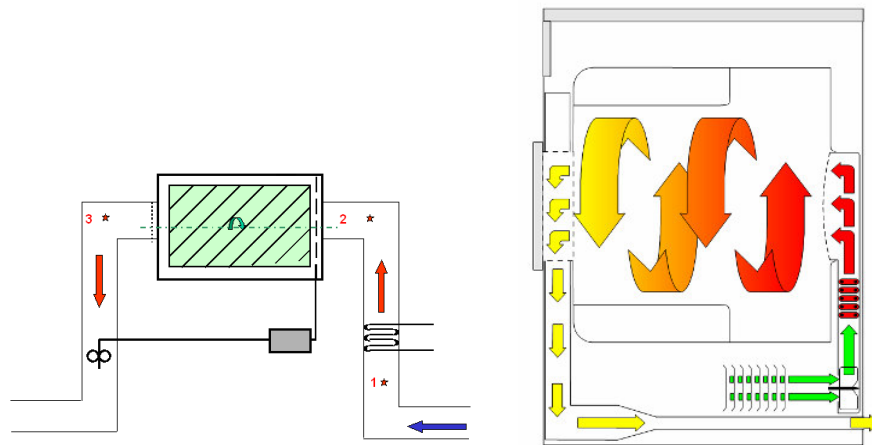

Figure 108: Air flows in the air vented tumble dryer⁶²

1. Input heating element
2. Input tumble
3. Output tumble

Fresh and dry air comes from the room where the dryer is located. The heating element warms up the air. Between 1 and 2, there is no condensation and vaporization; as a result water content remains constant. So the enthalpy is just varying with the temperature (See Figure 109).

$$\Delta H = a\Delta T + b \quad (10)$$

Where:

$$a = C_{pA} + rC_{pV} \text{ and is a constant}$$

$$b = r\Delta H_V \text{ and is a constant}$$

$$\Delta T = T_2 - T_1$$

⁶¹ Source: CETIAT

⁶² Sources: Fagor-Brandt (left) / Gorenje (right)

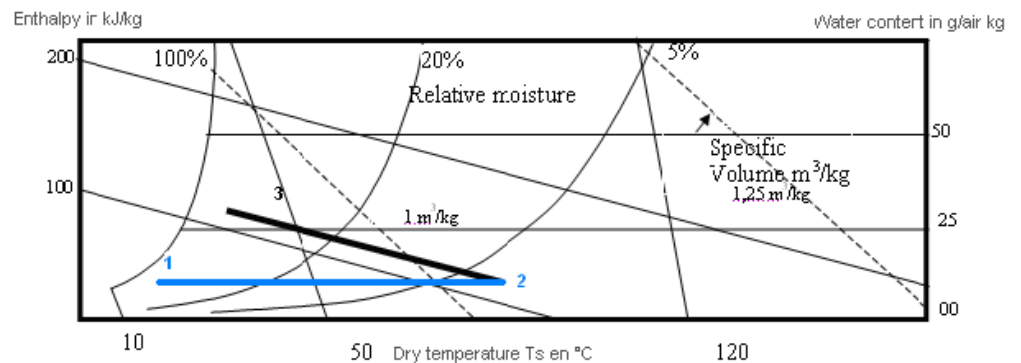

Figure 109: Theoretical variation of the enthalpy between 1 and 2 means for the heating of ambient air⁶³

Inside the tumble (between stage 2 and 3), water is vaporized. During this phase, air temperature is decreasing, whereas its water content is increasing. In reality, there is no enthalpy variation. Actually, when the drying occurs, the air loses its energy, which will be used to evaporate the laundry's water (energy transfer). At the same time, the air collects this water (mass transfer) and is evacuated outside.

Between 2 and 3,

$$\Delta H = 0$$

$$0 = C_{pA} \cdot \Delta T + r(C_{pV} \Delta T + \Delta H_{vapour})$$

Where:

$$\Delta T = T_3 - T_2$$

The relative moisture becomes a function of the temperature. So, theoretically, the drier and hotter the air is when it enters the tumble, the more efficient the drying process.

But in reality, an important increase of the temperature goes always hand in hand with energy losses. Consequently, only an optimum between temperature and losses has to be found.

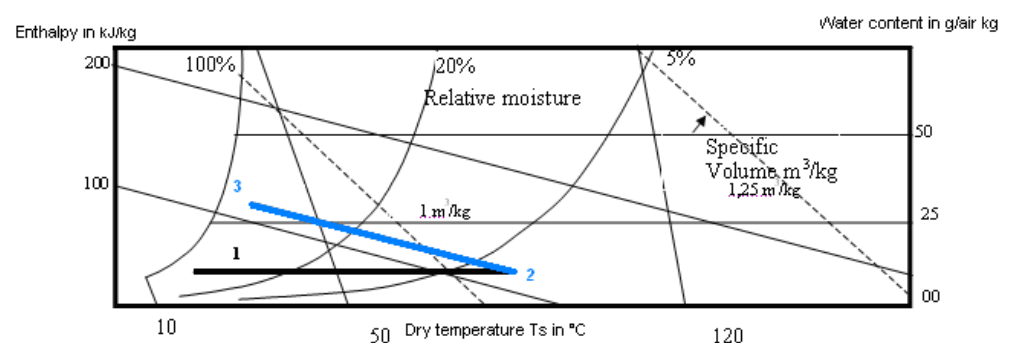
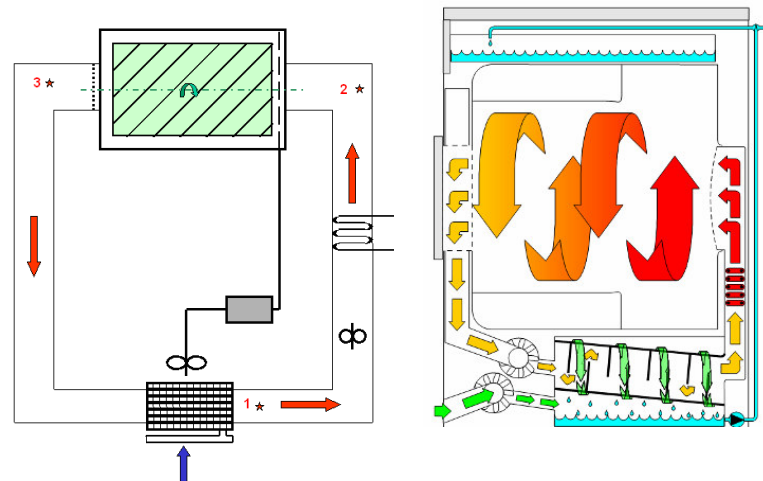

Figure 110: Variation of the enthalpy between 2 and 3, when the dry air goes through the tumble⁶⁴

⁶³ Source: Fagor-Brandt

Application to the air condenser tumble dryer

Figure 111: Air flows in the air condenser tumble dryer⁶⁵

4. Output condenser
5. Input tumble
6. Input condenser
7. Inside of the condenser

The two first steps of the drying process are the same as in an air vented tumble dryer: The heating element warms up the air.

Between 1 and 2, there is neither condensation nor vaporization: as a result, the water content remains constant. Inside the tumble, (between stage 2 and 3), water is vaporized. During this phase, air temperature decreases while its water content increases. The drying occurs at a constant humid temperature (there is no exchange with the outside). When the drying process occurs, the air loses its energy, which will be used to evaporate the laundry's water (energy transfer). At the same time, the air collects this water (mass transfer).

At stage 4, the condenser cools the air until the humid air reaches the dew-point (100% of relative moisture). This cooling is done without condensation: as a result, the water content remains constant.

$$\Delta H = a(T_4 - T_3) + b \quad (11)$$

Where a, b are constant

During the last phase (4 to 1), there is condensation and the water is collected in a container:

$$\Delta H = \Delta H_{condensation} \quad (12)$$

⁶⁴ Source: Fagor-Brandt

⁶⁵ Sources: Fagor-Brandt (left) / Gorenje (right)

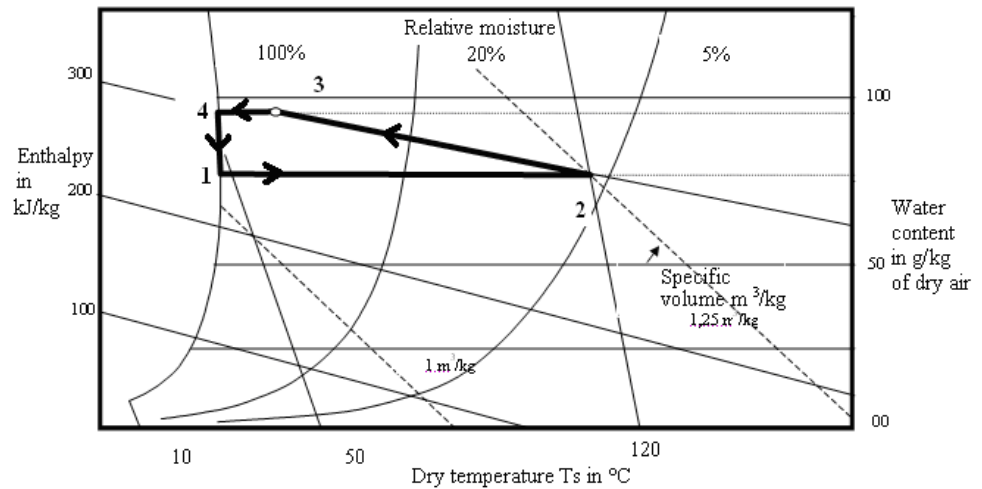

Figure 112: Thermodynamic cycle of an air condenser tumble dryer⁶⁶

IV.4.2 Internal factors influencing the energy consumption

Tumble dryers offer a fast and convenient way to dry textile but the vast majority of tumble dryers are class C to D. So identifying internal sources of energy consumption and losses is an important issue.

Case of air vented tumble dryers

In order to identify possible source of energy improvement which will be detailed in Task 6, the basis is the energy balance of the dryer (See 33).

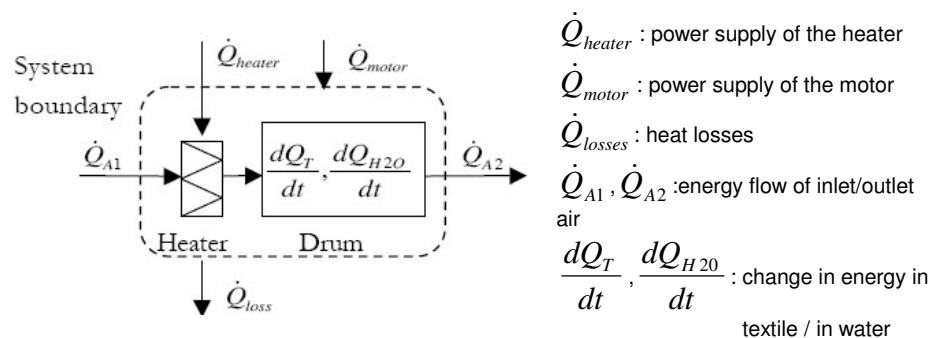

Figure 113: Energy flows in an open circuit tumble dryer (air vented)

The main sources of energy consumption are represented on 33: the motor and the heating element. But the energy in the air at the inlet has an impact, and so do thermal losses.

First, the motor energy consumption is responsible for about 7% of the total energy need. The type of motor used will have to be studied. Moreover, the electrical energy consumed for the drying process largely depends on the power supply of the heating element. Theoretically, the drying efficiency depends on the difference between specific moisture content at the inlet and at the outlet of the drum (improved when as large as

⁶⁶ Sources: Fagor-Brandt

possible), so the air must be heated at the circuit inlet and that is why there is a heating element. But, a compromise between energy efficiency and drying efficiency must be found. Three parameters will have to be studied:

8. Airflow,
9. Air temperature,
10. Drying period.

These parameters are also reflected in the settings for fan speed, drum speed and heating temperature.

Case of air condenser tumble dryers

In general, the energy consumption of air condenser tumble dryers is higher than for air vented dryers.

The energy balance for this type of dryer is different from the balance of an open circuit dryer.

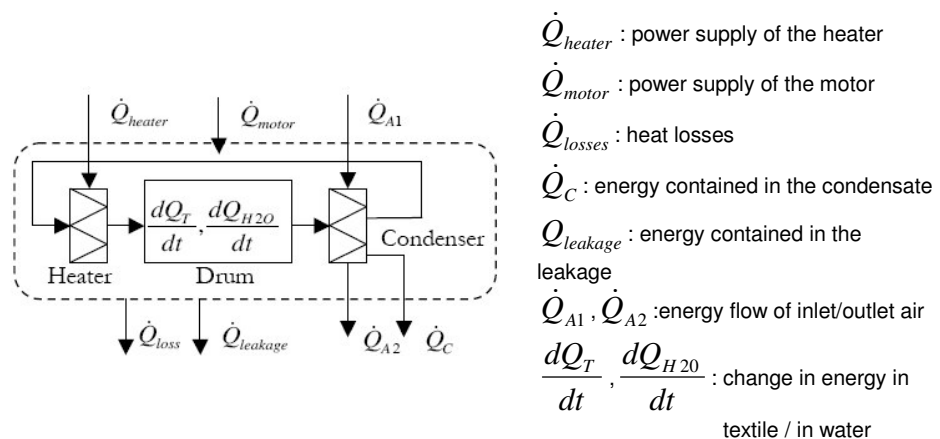

Figure 114: Energy flows in a closed circuit tumble dryer (condenser)

Two new parameters appear in the case of a condenser tumble dryer:

- Leakage in the circuit,
- Efficiency of the condensation.

Leakages in the internal circuit may appear either between heater and drum or between drum and condenser. The first type of losses has the greatest impact because the air is heated but is not used for the drying process: it constitutes dead losses.

In the case of a closed circuit tumble dryer, the efficiency of the condensation process has a significant influence. This is influenced by the design of the exchanger, which should ensure that the exchanged heat only supplies the energy necessary for the condensation and that no energy is coming out (thermal losses) cooling the air. However, the intrinsic characteristics⁶⁷ of the exchanger are not the only ones to influence the energy efficiency, the quality and the cleanliness of the filter also play an important part in the exchanger properties. Indeed, as previously seen, an accumulation of fibres on the condenser reduces heat exchanges and thus the efficiency of the process.

⁶⁷ Type : air-air crossed flow, Efficiency

Special remark on control strategy

Finally, it appears that the control strategy influences the energy consumption of the dryer. Indeed a timer control dryer directly depends on the estimation of the drying time by the user before stopping the drying process. Whereas with an electronic controlled dryer the moisture content in the linen is taken into account, so the drying process varies with the quantity of clothes and the type of load. Usually time controlled dryers work longer than necessary resulting in a higher energy demand for a certain amount of clothes compared to humidity controlled dryers.

IV.4.3 Energy consumption of laundry dryers

This section deals with the energy consumption of the dryers both under standard conditions (i.e. according to the EN 61121:2005 standard) and real life conditions. These latter conditions are based on the “consumer behaviour” study (Task 3) with a specific usage pattern.

Standard and real life conditions

The standard conditions required by the test standard EN 61121:2005 are as follows:

Table 51: Standard conditions: general conditions for measurement

Ambient temperature (°C)	23°C
Ambient humidity (%)	55%
Laundry (tested)	Dry cotton
Selected programme	Dry cotton
Initial moisture content (of the laundry) (%)	60%
Spin speed (washing machine) (rpm) ⁶⁸	1000 rpm
Loading (weight of laundry. kg)	6 kg
Drying cycle duration (min)	Measured
Energy consumption (kWh)	Measured with the test method

According to Figure s coming from the manufacturers, the average drying cycle durations, measured under standard conditions, for the different types of laundry dryers are as follows:

Table 52: Average drying cycle durations measured under standard conditions (with a load of 6kg)

Air vented tumble dryer (Front)	125 minutes
Air vented tumble dryer (Top)	110 minutes
Compact air vented tumble dryer (Front)	100 minutes
Condenser tumble dryer (Front)	115 minutes
Condenser tumble dryer (Top) ⁶⁹	94 minutes

In the last version of the standard EN 61121: 2005, the conditions for the calculation of the energy consumption have changed compared to the previous version:

⁶⁸ Spin speed of the washing machine in number of rotations per minute (rpm).

⁶⁹ For the top dryer the loading is of 5kg.

- 60% of initial moisture instead of 70%,
- 23 °C for ambient temperature instead of 20 °C,
- 55% for ambient humidity instead of 65%,

Then for the classification according to the energy label Directive 95/13/EC, the energy consumption E , measured under the new conditions requested by the standard EN 61121:2005, is corrected as follows:

- For a vented dryer by the calculation of the equation:

$$E_{\text{corr}} = E \times 1,14 + 0,08 \text{ [kWh / h]} \times t$$

Where t is the total program time expressed in hours.

- For a condenser dryer by multiplying E by 1,14:

$$E_{\text{corr}} = E \times 1,14$$

Note: This correction is necessary to maintain the energy label class classification unchanged due to the change in testing conditions compared to EN 61121:1999.

- For an air vented tumble dryer, the energy consumption of a Class C tumble dryer is $0,59 < E_{\text{corr}} \leq 0,67 \text{ kWh / kg}$
- For a condenser tumble dryer, the energy consumption of a Class C tumble dryer is: $0,64 < E_{\text{corr}} \leq 0,73 \text{ kWh / kg}$

In the following E_{corr} is considered to be the Energy EL, according to the Energy Label.

The conditions for the chosen product usage pattern definition are as follows:

Table 53: Product usage pattern definition (Real life conditions)

Ambient temperature (°C)	23 °C
Ambient humidity (%)	55%
Laundry (tested)	Dry cotton
Selected programme	dry cotton
Initial moisture content (of the laundry) (%)	55%
Spin speed (washing machine) (rpm ⁷⁰)	1217 rpm
Loading (weight of laundry. kg)	3.4 kg
Drying cycle duration (min)	To be calculated according the correction formula
Energy consumption (kWh)	To be calculated according the correction formula

The duration of the cycle and the energy consumption of the laundry dryer depend on the real life conditions. The following section deals with a proposal of correction formula to calculate these data from the standard conditions.

⁷⁰ Spin speed of the washing machine in number of rotations per minute (rpm).

Proposal of a correction factor to calculate energy consumption under real life conditions

To take the correction factor into account, and after exchanges with industrials, we propose to calculate the duration of a drying cycle and the energy consumption (per drying cycle) as follows:

Correction formula to calculate the duration of the drying cycle

$$Duration_{real.conditions} = (Duration_{Standard} - 10 \text{ min cool.down}) \times \frac{55\%}{60\%} \times \frac{3,4\text{kg}}{6\text{kg}} + 10 \text{ min cool.down}$$

Where:

- Duration_{Standard} = Duration under standard conditions (Table 52)
- Cool down time is estimated to be 10 minutes

Correction formula to calculate the energy consumption

$$Energy_{real.conditions} = Energy_{Standard} \times \frac{55\%}{60\%} \times \frac{3,4\text{kg}}{6\text{kg}} \times \text{Correction.factor.or.smaller.load}$$

Where:

- Energy_{Standard} = Energy under standard conditions
- Correction factor for smaller load is estimated to be 1,15

With these formulas, the drying times and energy consumptions under real life conditions can be calculated based on those under standard conditions for the different types of tumble dryers.

Average duration of a drying cycle under real life conditions

For the different drying cycle durations, the standard values allow to calculate:

Table 54: Average drying cycle durations calculated for real life conditions (with a load of 3.4kg)

Air vented tumble dryer (Front)	69.7minutes
Air vented tumble dryer (Top)	72.3 minutes
Compact air vented tumble dryer (Front)	103.8 minutes
Condenser tumble dryer (Front)	64.5 minutes
Condenser tumble dryer (Top)	53.6 minutes

Energy consumption of an air vented tumble dryer

In standard conditions

The average energy consumptions for the considered dryers are:

Table 55: Average energy consumption of air vented tumble dryers under standard conditions

Model	Energy class ⁷¹	Energy consumption (Actual. E)	Energy consumptions (Corrected. E _{corr})
Air vented tumble dryer (Front. 6 kg)	C	0.56 kWh / kg 3.36 kWh / cycle	0.67 kWh / kg 4.00 kWh / cycle
Air vented tumble dryer (Top. 5kg)	D*	0.66 kWh / kg 3.3 kWh / cycle	0.78 kWh / kg 3.91 kWh / cycle
Air vented tumble dryer (Compact. 3 kg)	D*	0.6 kWh / kg 1.8 kWh / cycle	0.73 kWh / kg 2.19 kWh / cycle

* According to the Energy Label, the energy consumption of a D class air vented tumble dryer is: $0.67 < E_{corr} \leq 0.75$ kWh/kg.

According to real life conditions

The real life average energy consumptions per drying cycle for the considered dryers are calculated as follows from actual energy consumptions (E_{Actual}):

Table 56: Average energy consumption of air vented tumble dryers under real life conditions

Model	Energy class	Energy consumptions (Actual, under real life conditions)
Air vented tumble dryer (Front, 6 kg)	C	2.01 kWh / cycle

The real life condition scenario does not apply to compact air vented tumble dryers nor dryers with a 5 kg capacity.

Energy consumption of a condenser tumble dryer

According to standard conditions

The average energy consumptions for the considered dryers are:

Table 57: Average energy consumption of condenser tumble dryers under standard conditions

Model	Energy class	Energy consumption (Actual. E)	Energy consumptions (Corrected. E _{corr})
Condenser tumble dryer (Front. 6 kg)	B*	0.56 kWh / kg 3.36 kWh / cycle	0.64 kWh / kg 3.83 kWh / cycle
Condenser tumble dryer (Front. 6 kg)	C	0.64 kWh / kg 3.84 kWh / cycle	0.73 kWh / kg 4.38 kWh / cycle
Condenser tumble dryer (Top. 5kg)	C	0.698 kWh / kg 3.49 kWh / cycle	0.796 kWh / kg 3.98 kWh / cycle

* According to the Energy Label, the energy consumption of a B class condenser tumble dryer is: $0.55 < E_{corr} \leq 0.64$ kWh / kg.

⁷¹ The energy efficiency scale for dryers is presented in Annexe

According to real life conditions

The real life average energy consumptions per drying cycle for the considered dryers are calculated as follows from actual energy consumptions (E_{Actual}):

Table 58: Average energy consumption of condenser tumble dryers under real life conditions

Model	Energy class	Energy consumptions (Actual. under real life conditions)
Condenser tumble dryer (Front. 6 kg)	B	2.01 kWh / cycle
Condenser tumble dryer (Front. 6 kg)	C	2.29 kWh / cycle

The real life scenario does not apply to dryers with a 5 kg capacity.

Energy consumption: breakdown per main components / subparts

Regarding the main elements which consume energy during a drying cycle, and according the two main types of technologies and the energy classes, here are the following Figure s (under standard conditions):

Table 59: Breakdown per components & subparts of the energy consumption of several types of laundry dryers (E_{Actual} under standard conditions with a load of 6kg)⁷²

Energy consumption	Motor + Fan	Heating element	Electronics / Pump
Air vented tumble dryer Front C Class	260 Wh	2785 Wh	10 Wh
	8,6%	91,1%	0,3%
Air vented tumble dryer Top D Class	200 Wh	3100 Wh	-
	6%	94%	-
Condenser tumble dryer Front C Class	395 Wh	2780 Wh	10 Wh
	12,4%	87,3%	0,3%
Condenser tumble dryer Front B Class	313 Wh	3005 Wh	10 Wh
	9,4%	90,3%	0,3%
Condenser tumble dryer Top C Class	429 Wh	3066 Wh	-
	14%	86%	-

According these Figure s, the principal energy consuming component of all the types of dryers is the heating element, with around 90% of the total energy consumption.

⁷² Manufacturers data available, collected by questionnaire, like the BOM

IV.5 Use phase (System)

IV.5.1 External factors influencing the energy consumption

Most of the time energy efficiency labelling is made under specific conditions of temperature (23°C), humidity (55%), etc. and with a specific load type (cotton), defined in the standard EN 61121:2005. It is interesting to vary these parameters in order to study their influences on the energy consumption of dryers.

Then five external parameters, which have been identified as having an influence on the energy demand in the use phase⁷³ are:

- The fabric type,
- The loading of the dryer,
- The spin speed of the washing machine,
- The ambient air humidity,
- The ambient air temperature.

Types of fabrics

Some types of fabrics hold the water stronger than other, thus increasing the energy needed to dry them. But, as previously presented in Task 3, 70 to 80% of the fabrics are dried using the cotton program. Thus, only this type of load is generally studied⁷⁴.

Loading of the dryer

It is generally accepted that a larger capacity leads to a better efficiency. This becomes clear from data on compact venting dryers (load of 3kg) which have an average energy consumption of 0,6 kWh/kg compared to 0,56 kWh/kg for dryers with a capacity of 6kg. Indeed, the total energy consumption does not solely depend on the amount of water to evaporated and load to be heated: there is also a part which depends on the energy necessary to heat up the machine (\dot{Q}_{loss}), to lead the drum, to control the temperature, etc. Consequently energy consumption does not vary linearly with the load (See Table 60).

Table 60: Influence of the load on the energy consumption⁷⁵

Loading	5 kg	4.5 kg	4 kg	3.5 kg	3.2 kg	3 kg
Total energy demand (per cycle)	100 %	93 %	85 %	78 %	73 %	70 %
Specific energy demand (per kg)	100 %	103 %	106 %	111 %	114 %	117 %
Data quality	m	m	m	m	i	m

m = measured data for 'cotton dry' programme⁸

i = interpolation

The spin speed of the washing machine

The energy demand of the laundry dryer depends on the remaining water in the clothes after spinning in the washing machine.

The more efficiently clothes have been spun, the smaller the energy needed for drying them. Considering that to remove an equal quantity of humidity, the thermal process

⁷³ Source: Öko-Institut e.v. (2004)

⁷⁴ Source: Brunzell (2006). *Energy Efficiency Textile Drying*

⁷⁵ See Note 39

used in a dryer needs more energy than the mechanical one used in washing machines, it appears that a better spin will be more appropriate.

A correlation between spin speed and dryer energy demand may be established⁷⁶ as shown in Table 61.

Table 61: Relative energy demand with respect to spin speed / remaining water after spin

Water remaining after spin (cotton)	70%	60%	50%	43%
Corresponding approximately spin speed	800	1000	1400	1800
Relative energy demand ('cotton dry' programme)	100%	89%	74%	63%

This has also been studied in the Lot 14 study on washing machines.

Ambient air humidity

Air humidity has an influence on the energy demand of air vented dryers.

With a lower humidity the energy demand decreases. As presented before, at 20°C, the relative humidity of 65% means an absolute humidity of 9,45g per kg air. The dependency of electricity consumption of air vented dryers against absolute humidity at a certain temperature can be calculated according to the following function proposed⁷⁷:

$$\Delta E = (0.00832 * x - 0,079) * 100$$

With ΔE : the deviation from electricity demand at 20°C in %

x : the absolute humidity in g/kg dry air

This function is given for a reference temperature of 20°C; some corrections have to be made if this temperature varies.

Table 62: Maximum saturation and absolute humidity at different temperatures and relative humidity

Temperature (in °C)	maximum saturation (in g/kg)	absolute humidity (in g/kg)		
		65% r.h.	40% r.h.	25% r.h.
0	3.76	2.45	1.50	0.94
5	5.43	3.53	2.17	1.36
10	7.63	4.96	3.05	1.91
15	10.59	6.88	4.23	2.65
20	14.53	9.45	5.81	3.63
25	19.76	12.84	7.90	4.94
30	26.41	17.16	10.56	6.60

⁷⁶ Source: Öko-Institut e.v. (2004)

⁷⁷ Source : Miele (2004)

Ambient air temperature

The electricity consumption of a dryer depends on the ambient temperature.

For both type of dryers, when the temperature decreases the energy demand increases. But the difference in the energy demand is more significant in the case of air vented dryers. Between 5°C and 30°C and with a relative humidity of 65%, the dependency of electricity demand with the temperature is given by the following functions⁷⁸:

For air vented dryers:

$$\Delta E = (-0,01153 * T + 0.231) * 100$$

For (air) condenser dryers:

$$\Delta E = (-0,002147 * T + 0.04293) * 100$$

Where:

- ΔE = Deviation from electricity demand at standard conditions in %
- T = ambient temperature in °C

For both formulas, the reference temperature is 20°C

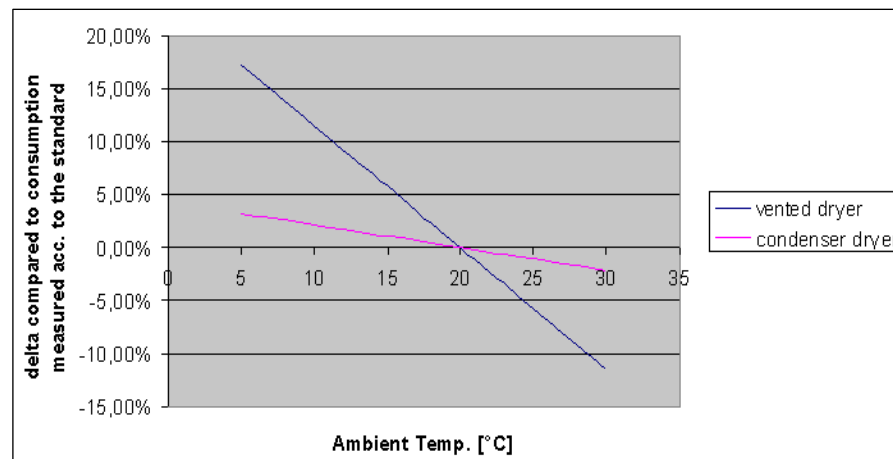

Figure 115: Influence of the ambient temperature on the energy consumption of dryers.

Customer behaviour

As explored in Task 3, the user behaviour has a large influence on the energy consumption of a dryer. Indeed, the user can act on it at three different levels:

- by cleaning regularly its filter,
- by choosing a more economical program,
- by choosing an appropriate location for the appliance, as presented in the following paragraph.

⁷⁸ Source : Ökoinstitut, MIELE

IV.5.2 Modelling use phase considering atmospheric parameters

Regarding the influence of atmospheric conditions, the location of the dryer has to be taken into account in order to define the energy efficiency of tumble dryers.

Regarding the influence of ambient conditions, changes in energy demand due to changes in the ambient temperature mainly have to be taken into account when dryers are located outside heated room, in a garage for example.

The influence of space heating is introduced in this paragraph. When the dryer is located in a heated room (kitchen, bathroom, etc), the energy demand for space heating has to be considered when comparing the energy demand of both dryer types.

Indeed, air vented tumble dryers have an additional energy demand as the warm and humid air is blown to the outside and is replaced by cold air that has to be reheated by the space heating system.

Condenser tumble dryers cool down the warm and humid air and condense the steam. The condenser tumble dryers warm up and give this heat to the ambient air thus replacing a certain amount of space heating.

At least during the heating period the consideration of space heating energy demand may lead to additional energy demand of air vented tumble dryers and to credits for saved heating energy for condenser tumble dryers. To a minor extent, air vented dryers also give a certain amount of heat to the ambient air.

Two different scenarii for each type of dryer have been identified by the Öko-Institut study. (See Figure 116)

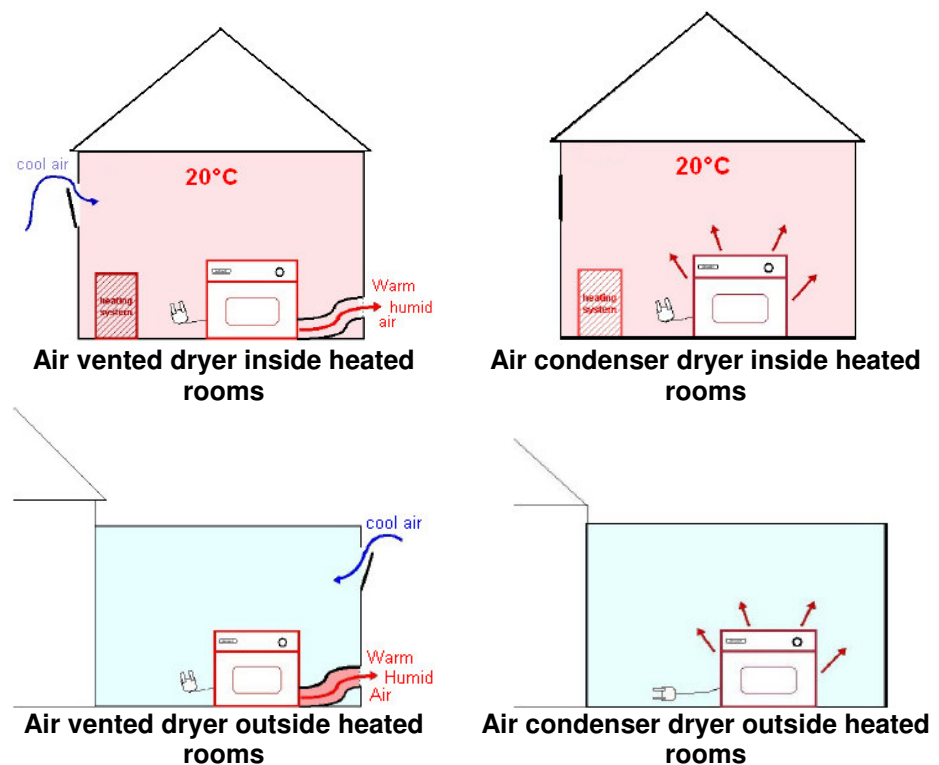

Figure 116: Dryer use inside or outside heated rooms⁷⁹

⁷⁹ Source : Öko-Institut e.v. (2004)

The total energy demand of tumble dryers during the use phase is determined by the specific energy demand of the regarded tumble dryer, a certain amount of space heating energy demand (for open circuit dryers located inside) and credits for space heating energy demand (for condenser dryers, and to a minor extent open circuit dryers, located inside)⁸⁰.

Moreover, to ensure applicability of this study for different European regions, climatic differences within Europe have to be considered. Indeed climate may influence both the effects on the specific energy demand (ambient temperature) and space heating effects. Thus, three different zones were defined:

- The cold climatic zone, represented by Norway,
- The moderate climatic zone, represented by Germany and France,
- The warm climatic zone, represented by Spain.

Based on the different parameters previously mentioned, the following paragraphs present the results of the study carried out, with several sensitivity analyses.

General results for energy demand (energy consumption)

Use of dryers inside heated rooms

In all climatic zones, the energy demand of air vented dryer increases when used under real life conditions and accounting for space heating effects. In contrast the energy demand of condenser dryers decreases. This also applies to all zones.

Use of dryers outside heated rooms

The energy demand of air vented dryers increases to a greater extent than that of condenser dryers when the ambient temperature falls below the standard temperature (20°C). Condenser dryers, which have a higher electricity demand compared to air vented dryers under standard conditions, can thus see it compensated, possibly resulting in an overall energy demand lower than that of air vented dryers.

On the other hand, the energy demand of air vented dryers also decreases to a greater extent than that of condenser dryers when temperature rises above the temperature under standard conditions. This effect results in an increase of the already existing difference between air vented and condenser dryers under standard conditions.

Both when used indoors and outdoors, the differences between energy demand under real life conditions and standard conditions are the highest for Norway (country with a cold climate) and decrease when moving to warmer countries, being the smallest for Spain (country with a warm climate).

Sensitivity analyses

Sensitivity analysis with reduced loading

The energy consumption was compared for an average loading (3,4 kg per cycle) instead of a standard loading (6 kg): with reduced loading, more electricity is needed to dry the same amount of laundry. This effect is not considered in the energy calculation under standard conditions and thus increases the difference between standard and real life energy demand, for both for the indoor and outdoor scenarii.

⁸⁰ Source : Öko-Institut e.v. (2004)

Sensitivity analysis with use during the heating period

The space heating and ambient temperature effects, that are both advantageous for condenser dryers, mainly apply during the heating period. During the summer period, the use of an air vented dryer might be better in terms of energy demand. Levels turn out to the advantage of condenser dryers during the heating period.

The reduction of the standard electricity demand of condenser dryers is greater when considering use only during the heating period.

The indoor case is more sensitive to this parameter and changes more than the outdoor case.

Sensitivity analysis with remaining water content after spin

The effect of decreasing the percentage of remaining water after spin is the same whether the dryer is used inside or outside heated rooms.

Sensitivity analysis with air extraction rate of air vented tumble dryers

With the higher air-extraction rate of air vented dryers (150m³/h instead of 120 m³/h), the amount of air that is blown to the outside has to be replaced by cold air and then has to be reheated by the space heating system increases. This results in a higher space heating energy demand for air vented dryers.

There is no change for the outdoor use.

Sensitivity analysis with drying time

The length of the drying cycle time determines (among other parameters) the total amount of air extracted by air vented dryers. This only has an effect when air-vented dryers are used indoors as the amount of extracted air only influences the additional energy demand from space heating.

Longer cycle times mean a larger amount of extracted air and thus more space heating energy is required. As the energy demand of condenser dryers stays constant, this means a relative decrease of the performance of air vented dryers compared to condenser dryers. The effect is stronger in countries with a colder climate.

Sensitivity analysis with relative humidity of air

The relative humidity of the air influences the energy demand of air vented dryers. Under standard conditions, the relative humidity is set to 55%, but it can go as high as 80%.

With a lower humidity, the energy demand of air vented dryers decreases. Similarly, depending on the humidity (and external temperature), the base case energy consumption (2.01 kWh/cycle) can be multiplied by a factor three with high humidity.

In the best case (with well-mixed air and an homogeneous temperature and humidity) the dryer performance are much better. Lower air humidity lowers the electricity demand and thus also the space heating energy demand of air vented dryers. The energy demand of condenser dryers is not affected. It is the same for both indoor and outdoor use.

Sensitivity analysis with space heating credits

It is assumed that during the heating season, 50 % of the electricity demand of condenser dryers can be credited against the space heating demand, replacing a corresponding amount of space heating energy demand.

This applies to condenser dryers only when located indoors in heated rooms. There is no change for outdoor use. These different aspects are also investigated in task 5 (System Study) and 8 (Sensitivity analysis).

IV.6 End of life phase

Concerning the end of life of the dryers and according to the Task 3 study on the consumer behaviour, the way of disposing of an old dryer (after 10 to 19 years of use ; we have considered an average life time of 13 years), is for most of the cases:

to bring it to a selective communal collection of waste (32% of respondents)

or

to respect the rule 1 for 1 (31% of respondents): when they buy a new appliance, they return the old one (requirement coming from the WEEE Directive 2002/96/CE).

The rates of other ways of disposal of old dryers indicate few possibilities to extend the dryer life through second market or reuse.

Through these cases, it comes that it can be assumed that used laundry dryers will enter in selective and specialized treatment channels dedicated to WEEE. Based on the results of the ECO'DEEEE⁸¹ project (lead by CODDE, the end of life steps of the laundry dryers can be described as follows.

The average weight ratio of each material of an air condenser tumble dryer can be represented as follows:

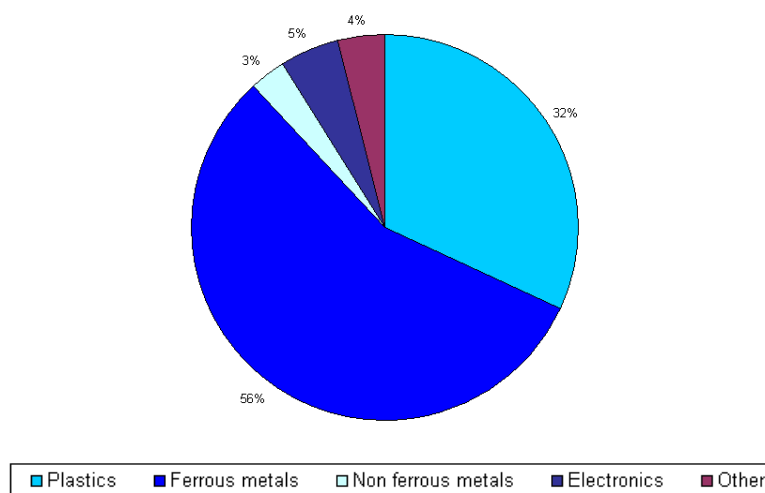

Figure 117: Weight ratio of the materials of an air condenser tumble dryer

Used laundry dryers which are not used as second hand (see Task 3, the share of tumble dryers purchased on the second-hand market represents only 6.6%), are re-treated for most of them in the grinding channel. Indeed, used household appliances such as laundry dryers and washing machines are grinded and the material is recycled.

⁸¹ ECO'DEEEE project: Project managed CODDE. The main objectives of the project were to find areas for design improvement of electrical and electronic products (EEE) in order to make easier recycling and cleaning up. This project allowed identifying optimisations angles of the WEEE sector and consequently to reduce WEEE treatment costs. The ECO'DEEEE project was sponsored and cofinanced by the ADEME (Agence De l'Environnement et de la Maîtrise de l'Energie) in France. Among the industrial partners involved in the project: FagorBrandt, Neopost Technologie, Sagem Communication, Schneider Electric, SEB. The project began in 2006. It will be finished by the beginning of 2009.

This channel is composed of the following steps.

The used equipment, included in the group of white products (household appliances) apart from cold appliances (such as cooking machines or dishwashers), are transported to the "grinding" plant where they are cleaned up, shredded and grinded together.

Two main possibilities of treatment can occur, concerning the flow of equipment:

Large household appliances:

Manual cleaning up



« Desintegrator »



(Manual sorting and) automatic sorting with thin shredders included

or

Mixed small equipments:

« Desintegrator »



Pollutants manual sorting



Thiner shredder
(Granulator)



(Manual sorting and) automatic sorting with thin shredders included

Description of the main steps of treatment:

Cleaning-up « pre-desintegrator »:

Operators remove equipment cables and some capacitors (the main ones if possible).



Figure 118: Used washing machines and laundry dryers

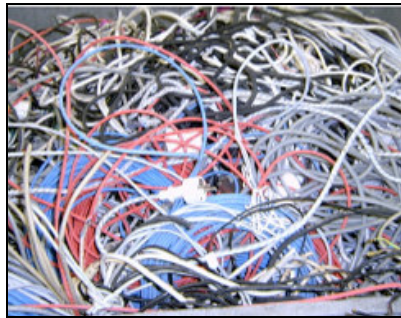

Figure 119: Removed cables



Figure 120: Removed capacitors

Desintegrator:

During this step, the laundry dryers are shredded with other white household appliances (apart from cold ones).



Figure 121: Desintegrator for household appliances

Cleaning up post-desintegrator:

The laundry dryers are already shredded and operators remove pollutants from the grinded parts which pass in front of them on the treadmill.



Figure 122: Cleaning up of shredded equipment

The pollutants to be removed are:

- Capacitors,
- LCD display panels (from the new generation laundry dryers),
- Possibly the printed circuit board.

Other elements can be removed along this step of cleaning up:

- Foams which can disturb the subsequent sorting of materials,
- Motor(s) (composed of large quantities of copper which can be sold to a scrap metal dealer,
- Cables (which are separately treated because they contain copper),
- Some aluminium or stainless steel parts (example: drum) which can be also sold a good price.

Granulator

Following the manual cleaning up and the disintegrator, another shredder grinds the “pre-shredded” elements in smaller pieces (chips of 3 cm). This size of shredded pieces will suit with the downstream processes.



Figure 123: Granulator (to shred elements in small pieces)

In order to remove the wool copper, a sorter is used after the granulator.

Automatic sorting of the different fractions

The sorting of fractions is completely automatic.

First, the flow of small shredded pieces is brought back up by a pump.

Then the flow enters in a separator which separates the light part (A), which is sucked in, from the heavy part (B) which falls on the treadmill at the bottom of the separator.



Figure 124: A- The light part is sucked in



Figure 125: B- The heavy part falls on the treadmill

A- The light part is generally composed of plastic films, papers and cardboard which disturb the subsequent sorting of the other part.

This part enters in a dust collector then in a big bag and finally it is incinerated.

B- The heavy part is composed of the remaining materials: ferrous and non ferrous (mainly aluminium) metals, heavier plastics and some printed circuit boards (PCBs are too heavy to be sucked in).

- B1- The heavy part passes then under a magnet which removes all the magnetic ferrous elements.
- B2- The remaining elements are: stainless steel, some printed circuit boards, plastics and non ferrous parts. The PCBs are removed from this flow. This is done thanks to a system with a digital camera and a metal detector. The camera identifies the « green » and the « brown » while the metal detector identifies the metal composition. If both “green or brown” and « presence of metals » are detected then the component is ejected. This system has a very low error margin.
- B3- The remaining materials are stainless steel, aluminium, some other ferrous metals (part B3A), plastic parts and rubble (part B3B). These latter elements (rubble and plastic parts) are removed from the flow by Foucault currents:
 - B3-A- Stainless steel and non ferrous materials (aluminium, copper, brass, tin):

These chips of non magnetic material are more finely shredded. They are then sorted by densimetric or gravimetric sorting: aluminium and stainless on one part, rubble on the other one.



Figure 126: Densimetric sorting (vibrating table – dry way)

- B3- B- Plastics, rubble and other impurities:

Rubble is finely shredded and could be sold as sand for civil engineering. But, even if plastics are recyclable, most of them are finally incinerated at the end of end of life treatment.

If recycled, the different plastic parts are separated by densimetric sorting (wet way). This is possible because there a few types of plastics in white household appliances.



Figure 127: Rubble parts



Figure 128: Plastic parts

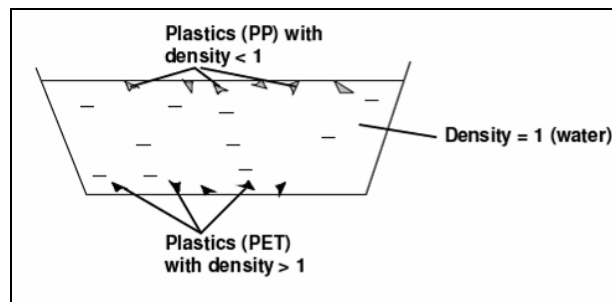

Figure 129: Densimetric sorting of plastic parts (wet way)

Considering the ratio of recycling, incineration and discharge, according to the ECO'DEEE project the following Figure s are obtained:

Notes:

- In the table and the graphic, the incineration with or without energy recovery are not distinguished. If possible it would be better to choose an incinerator with energy recovery. The reuse scenario is not considered.
- The Figure s are adapted⁸² to laundry dryers but were originally obtained for washing machines.

Table 63: Weight ratios for the three types of end of life treatments

Category	Material recovery (Recycling) %	Incineration %	Discharge %
Electronic components	0	6.5	0.3
Ferrous metals	62.5	0	3.3
Non ferrous metals	2.6	0	0.1
Polypropylene	1.9	16.2	1
Other plastics	0	5.3	0.3
Total	67.0	28.0	5.0

⁸² The same ratios for the end of life treatments were applied, but concrete was excluded since it is present in washing machines (27% of the mass) but not in dryers

Annexes to Task 4

K References

- Brunzell L. (2006), *Energy Efficiency Textile Drying*, Thesis, Karlstad University studies
- Call conferences with FagorBrandt and Whirlpool, July 2008.
- CETIAT (Centre Technique des Industries Aérauliques et Thermiques, France)
- Fagor-Brandt (2001), *Présentation du principe de séchage*, Essaid Raoui.
- Group for Efficient Appliances (1995), *Dryers Long Term Efficiency Targets – A technical and Economic analysis*, report by VHK
- Miele (2004), Function derived from measurement conducted by Miele & Cie, Gmbh and Co.
- Palandre L. (2005), *Evaluation of high energy efficiency technical solutions for domestic dryers – Conception and modelling of a highly humid air mechanical compression dryer*, Thesis, Mines de Paris
- Öko-Institut e.V (2004), *Energy demand of tumble dryers with respect to differences in technology and ambient conditions*, Final Report, commissioned by European Committee of Domestic Equipment Manufacturers (CECED), Freiburg, 13 January 2004, Authors Ina Rüdener, Carl-Otto Gensch

L Summary of comments from stakeholders

Submission	Comment	Response
31/10/2008 S.A.F.E. (Swiss agency for efficient energy use)	Heat pump (HP) dryers are existing products, but not treated in task 4. As this is the only technology with really high saving potential, it should be treated, also to have a complete overview. Information was already submitted June 4, 2008; it is attached again.	The technical description relating to HP dryers is part of task 6. Indeed, as mentioned in your comment, HP dryers are dryers with high improvement potential and with low market share. Thus, in order to avoid redundancy in task 4 and 6, the choice was made to perform the analysis in task 6. The assessment of life cycle environmental impacts and costs will be performed in task 7. Considering HP dryers as a BAT was validated during the stakeholder meeting. A comment on this approach was added in the introduction.
31/10/2008 Natuur en Milieu	Chapter 2 A technical analysis of gas tumble dryers is missing. Although sales of this category is still low in Europe, this category should be taken into account as this technique is one of the best solutions for tackling the climate problem compared to the other tumble dryer categories.	Same treatment as for HP dryers.
31/10/2008 Natuur en Milieu	Chapter 5, p.47 Are there any results known about the influence of clogging of the filter on energy usage? If this is so important and there are techniques to prevent clogging this should be taken into account for BAT. Note: the wording on page 47 suggests that the cleanliness of the filter is very important and on p30 it is said that only in unusual cases this has influence of the energy consumption. This seems contradictory	No Figures are available about the influence of clogged filters. Concerning techniques to prevent clogging, the main one is to manually clean the filter. To make this easier, filters are usually easily reachable and some appliances indicate information related to the clogging of the filter. The cleanliness of the filter is important. The "unusual" cases refer to situations where the filter actually becomes so clogged that it hinders the normal working of the appliance.
31/10/2008 Natuur en Milieu	Chapter 5, p.49 Does the shorter average dryer cycle duration of "topdryers" compared to "frontdryers" mean that the energy usage is lower and if so how much % on average?	The shorter average duration of top dryers is due the fact that a 5kg load dryer is considered. This difference is taken into account in the annual number of drying cycles necessary to perform the functional unit.
31/10/2008 Natuur en Milieu	Chapter 5, p.49 A formula is shown to compare old with new data. From when is the new measurement, based on moisture content of 60%, compulsory.	The new measurement standard is in force since 2005.
31/10/2008	Chapter 5, p.52+53	Indeed, the energy efficiency scales are different for air vented and air

Submission	Comment	Response
Natuur en Milieu	Table 16 and 18 show that vented tumble dryers and condenser tumble dryers have a different label (C versus B) when the energy consumption is the same. This is not good for the credibility of the label as a B label suggests a better performance for the consumer. This should be taken into account when the criteria for the label are adapted.	condenser dryers to account for the fact that air vented dryers take more energy from the room space heating/ventilation system than air condenser dryers in usual operating conditions in Europe. Concerning the credibility of this label, a specific paragraph will be added in task 8. To ensure transparency for readers, the energy efficiency scale for each drying technology was added as an annexe.
31/10/2008 Natuur en Milieu	Chapter 6, p.56 Table 22 shows Figure s of the influence of spin speed on the remaining water content. At this moment washing machines are already sold with higher spin speeds (upto 1800 rpm). Claims are made for remaining water of 43% (www.miele.nl). I assume that you will add/check these Figure s.	This information has been checked and included in the report. However, such appliances are not common on the market.
31/10/2008 Natuur en Milieu	Chapter 6, p.60 Does the humidity of inlet air have an influence on the power consumption? In wintertime the absolute humidity is often lower due to a low temperature outside so the amount of absorbed water can be higher leading to a shorter cycle.	The humidity of inlet air (relative or absolute humidity) could have an influence on the drying time. As mentioned, if the humidity of inlet air is lower, the amount of absorbed water is higher. However, there is no data available to quantify this. Moreover, this shorter drying time could be translated into energy savings only if the dryer is equipped with humidity control.
31/10/2008 Natuur en Milieu	Chapter 6, p.68+69 In the report is sorting methods for plastics described, but 50 shows that almost no plastic is recycled. The conclusion should be added that although plastic recycling is possible at this moment recyclers prefer incineration.	Comment added on page 68.
31/10/2008 Danish Energy Agency	Task 4, 5, 6 include a very thorough and good technical description of the tumble dryer technology and analyses of best available technology.	

M Energy efficiency scale for tumble dryers

Energy efficiency scale for condenser dryers

A	B	C	D	E	F	G
<0.55	<0.64	<0.73	<0.82	<0.91	<1.00	>1.00

Energy efficiency scale relating to air vented dryers

A	B	C	D	E	F	G
<0.51	<0.59	<0.67	<0.75	<0.83	<0.91	>0.91

For tumble dryers the energy efficiency scale is calculated using the cotton drying cycle with a maximum declared load. The energy efficiency index is in kWh per kg of load. Different scales apply for condenser and vented dryers to account for the effect on space heating energy demand described in IV.5.2.

The label also contains:

- the energy consumption per cycle
- the capacity of the dryer
- whether the unit is vented or condenser
- the noise level in dB(A)

V Task 5: Definition of base case

V.1 Definition of Base Cases

Task 5 is dedicated to the definition of representative Base Cases. The Base Case is the point of reference for assessing the improvements, and is defined in terms of environmental impacts and financial costs. Most of the environmental impacts and Life Cycle Cost analyses throughout the rest of the study are built on it.

This task is divided into 5 subtasks:

1. The definition of Base Cases for laundry dryers
2. The collection of products specific inputs
3. The environmental assessment of the different Base Cases
4. The calculation of the Base Case Life Cycle Costs
5. The environmental assessment for EU totals

The description of the Base Case consists in a synthesis of the previous task conclusions and the general inputs (BOMs, energy consumption) are average data obtained from product manufacturers and were previously compiled in task 4. In order to allow future comparisons, a common functional unit is chosen for each Base Case.

In accordance with the MEEuP methodology, the life cycle environmental impacts and life cycle cost (LCC) are evaluated thanks to the EuP EcoReport methodology.

These two assessments will be used in order to evaluate the potential for improvement studied in task 6 and 7.

As demanded in the MEEuP methodology, one or two Base Cases per product have to be selected. The definition of Base Cases is given in function of the following functional unit:

“Drying the laundry of an average household during one year”

One representative Base Cases per main product categories (identified in Task 2) will be defined for the whole of the EU25 for laundry dryers.

- One Base Case for air vented tumble dryers
- One Base Case for air condenser tumble dryers

For each of these product Base Cases, two types of use conditions differentiate:

- A “**Standard Base Case**” (STBC), defined according to the standard conditions as defined in measurement standard or in legislation.
- A “**Real Life Base Case**” (RLBC), defined according to actual average consumer behaviour and ambient conditions. Most of these data come from the survey performed in task 3. When necessary, they are balanced and completed thanks to manufacturers’ data and inputs used in lot 14 relating to washing machines, to ensure coherent results over the whole “laundry care chain”.

Finally, sensitivity analyses relating to complementary products are performed: differences resulting in opening technology (top loading dryers) and in size (compact dryers) are evaluated.

V.1.1 Standard Base Cases definition

In accordance with Figures provided in task 4, a standard Base Case is defined for both product types studied.

As already mentioned in Task 4, standard conditions including ambient temperature, ambient humidity, laundry program, moisture content, spin speed and loading are the standard conditions as defined in EN 61121:2005.

Energy consumption and drying cycle duration were measured under standard conditions and provided by manufacturers.

In order to evaluate the same functional unit under real life conditions and standard conditions, it is necessary to assess the use phase with the same parameters: that is to say, the quantity of laundry dried in a year must be the same for both base cases types.

In order to evaluate this quantity, data from the survey conducted in task 3 were used:

- 3,62 cycles per week in winter
- 2,34 cycles per week in summer

Considering these results, the annual number of cycles under real life conditions can be evaluated as follows:

$$3,62 \text{ cycles/week} \times 26 \text{ weeks} + 2,34 \text{ cycles/week} \times 26 \text{ weeks} = 155 \text{ cycles/year}$$

However, this number corresponds to cycles under real life conditions, and thus to a load of 3.4 kg, as will be explained in V.1.2. Since the chosen functional unit, is "drying the laundry of an average household during one year", the same amount of laundry has to be considered in both cases. Since the load under standard conditions is 6 kg, the annual number of cycles under standard conditions has to be evaluated as follows:

$$\text{Annual number of cycles} = 155 \text{ cycles/year} \times 3.4\text{kg} / 6\text{kg}$$

Table 64: Standard Base Case (STBC) characteristics for both types of tumble dryers

	Air vented tumble dryers	Air condenser tumble dryers
Ambient temperature (°C)	23°C	
Ambient humidity (%)	55%	
Laundry (tested)	Dry cotton	
Selected programme	Dry cotton	
Initial moisture content (of laundry) (%)	60%	
Spin speed (washing machine) (rpm ⁸³)	1000 rpm	
Loading (weight of laundry, kg)	6 kg	
Annual number of cycles (cycles/year)	88	
Drying cycle duration (min)	125	115
Energy consumption per cycle (kWh/cycle)	3.36	3.6
Energy consumption per kg load (kWh/kg load)	0.56	0.60

⁸³ The spin speed of the washing machine is the number of rotations per minute (rpm).

Note:

Concerning compact air vented tumble dryers and top air condenser tumble dryers, the following annual number of cycles are defined:

- For compact air vented tumble dryers: 155 cycles x 3.4kg / 384 kg = 175
- For top air condenser tumble dryers: 155 cycles x 3.4kg / 585 kg = 105

V.1.2 Real Life Base Cases definition

The real life conditions are based on actual “consumer behaviour” and the Figures provided are the results of the survey performed in task 3, with adjustments discussed with manufacturers. Indeed, significant divergences between the task 3 survey, the manufacturers’ survey and existing studies on tumble dryers were identified:

- Concerning the load, the consumer survey provided an average value of 5,7kg of laundry per cycle. However, it appears that this value is probably over-estimated and corresponds to the capacity of the dryers rather than the actual load. In order to rectify this, and to ensure coherent results throughout the whole “laundry care chain”, the load value used for the preparatory study on washing machines (Lot 14) is considered, i.e. 3,4 kg.
- Concerning the programme used, the consumer survey in task 3 indicates that only 19% of the drying cycles are made with the cotton programme. Moreover, this value can be challenged. Indeed, the manufacturers’ survey shows that 75% of the laundry is dried using cotton programme. Moreover, existing studies on tumble dryers are performed with this programme. Therefore, only the cotton programme will be considered.
- Concerning the spin speed, the value extracted from task 3 is considered.
- Concerning the clogging of the filter, the impact of the clogging has not been taken into account. It was considered that the consumer cleans its laundry dryer filter appropriately.

Considering that the energy consumption is a function of the load and humidity, the drying cycle duration and the energy consumption were calculated in task 4 according to the following correction formula:

$$E_{RL} = E_{ST} \times \frac{55}{60} \times \frac{3.4}{6} \times 1.15$$

The energy consumption values were measured under standard conditions and provided by manufacturers for each model. The value considered for the Base Cases, as explained in Task 4, is the arithmetic average of the 6 corrected values.

⁸⁴ Maximum loading of the compact air vented tumble dryer

⁸⁵ Maximum loading of the top air condensed tumble dryer

Table 65: Real life Base Case (RLBC) characteristics for both types of tumble dryers

	Air vented tumble dryers	Air condenser tumble dryers
Ambient temperature (°C)	23°C	
Ambient humidity (%)	55%	
Laundry (tested)	Dry cotton	
Selected programme	Dry cotton	
Initial moisture content (of the laundry) (%)	55%	
Spin speed (washing machine) (rpm ⁸⁶)	1217 rpm ⁸⁷	
Loading (weight of laundry, kg)	3,4 kg	
Annual number of cycles (cycles/year)	155	
Drying cycle duration (min)	69.7	64.5
Energy consumption (kWh/cycle)	2.01	2.15
Energy consumption per kg load (kWh/kg load)	0.59	0.63

Concerning top condenser tumble dryers and compact air vented tumble dryers, no data concerning use under real life conditions are available.

⁸⁶ Spin speed of the washing machine in number of rotations per minute (rpm).

⁸⁷ Value extracted from task 3 consumer survey

V.2 Product-specific inputs (Subtask 5.2)

V.2.1 Principles

Product specific inputs were collected and organized according to the “EuP Eco Report” requirements and taking into account the LCA ISO 14 040 standards.

Most of the input data come from direct communication with manufacturers. They are spread out according to the different life cycle phases of the product.

Concerning the production phase, the following data were required:

- Used materials
- Energy consumption for assembling

Concerning the **distribution phase**, the following data were required:

- Volume of the packaged product
- Weight of the packaged product

Concerning the **use phase**, the following data were required:

- Energy consumption per cycle
- Annual number of cycles
- Energy consumption in off-mode
- Energy consumption in left-on (standby) mode
- Time passed in left on mode

The values used to characterize the use phase are the only ones affected by the drying conditions (standard or real life).

Concerning the **end of life phase**, the following data were required:

- Share of products re-used
- Share of products recycled
- Share of products incinerated

V.2.2 General assumptions

Concerning the production, distribution and use phases, the input data were collected from seven laundry dryers manufacturers:

- Bosch und Siemens Haushaltgeräte (BSH)
- CROSSLEE,
- ELECTROLUX,
- FAGORBRANDT,
- INDESIT,
- MIELE,
- WHIRLPOOL

Each of these producers selected their most representative model for each technology according to the characteristics specified for the base cases. Thus, concerning air vented tumble dryers and air condenser tumble dryers, the data analysis results in the identification of "a virtual average reference model" in terms of material in composition.

- This averaged approach was chosen because of a large discrepancy between the different models studied (see Table 66 and Table 67)
-). The relevance of such an approach will be justified during the assessment of the environmental impact.

Table 66: Deviation from the average for air vented dryers

	PP	Steel	Electronic Part	Computed weight	Energy Consumption
AV dryer 1	50%	15%	52%	16%	15%
AV dryer 2	-21%	14%	-26%	13%	1%
AV dryer 3	58%	-5%	100%	14%	0%
AV dryer 4	-29%	-31%	100%	-23%	5%
AV dryer 5	-63%	16%	37%	14%	2%
AV dryer 6	6%	-9%	-262%	-34%	-1%
Average	4158	22516	1566	34317	3

Table 67: Deviation from the average for air condenser dryers

SUBASSEMBLY	PP	Steel	Electronic Part	Computed weight	Energy
CD dryer 1	-45,44%	0,43%	-28,84%	8,28%	8,33%
CD dryer 2	11,85%	4,44%	-12,19%	14,63%	-6,73%
CD dryer 3	50,11%	-30,68%		14,86%	6,94%
CD dryer 4	-15,85%	-55,87%		-19,10%	11,11%
CD dryer 5	-11,23%	9,11%	61,31%	13,28%	6,43%
CD dryer 6	10,56%	-27,01%	-220,28%	-31,95%	0,00%
Average	7714,5	20132,2	1987,7	42159,2	3,6

Relating to compact and top loading dryers, only one manufacturer for each product category was considered. Consequently, accurate data were used.

Concerning the end of life phase, it was considered that laundry dryers are treated in treatment facilities for white appliances as described in task 4.

V.2.3 BOM and Inventory Data Collection for air vented dryers

BOM

The BOM is given for the Base Case air vented tumble dryer. The data provided by the manufacturers can only be classified by material type and not by subassembly.

The resulting BOM is presented in the following table.

Table 68: EcoReport material input table for the Base Case air vented tumble dryer

Nr	Product name	Date	Author	
	Air Vented Tumble Dryer (Front, 6kg) Standard		vhk	
Pos nr	MATERIALS Extraction & Production Description of component	Weight in g	Category Click & select	Material or Process select Category first!
1	Plastics			
2	Polypropylene	4157,0	1-BlkPlastics	4-PP
3	Polystyrene	364,5	1-BlkPlastics	5-PS
4	ABS	1306,8	2-TecPlastics	10-ABS
5	PA	98,7	2-TecPlastics	11-PA 6
6	POM	29,4	2-TecPlastics	
7	PMMA	29,7	2-TecPlastics	13-PMMA
8	PC	3,8	1-BlkPlastics	12-PC
9	PVC	99,8	1-BlkPlastics	8-PVC
10	Other	1336,7	2-TecPlastics	
11	EPDM - Rubber	198,3	2-TecPlastics	15-Rigid PUR
12	Metals			
13	Steel	12126,1	3-Ferro	22-St tube/profile
14	Stainless steel	2856,2	3-Ferro	25-Stainless 18/8 coil
15	Galvanized steel	3760,8	3-Ferro	21-St sheet galv.
16	Paint steel	3772,7	3-Ferro	22-St tube/profile
17	Aluminium	231,2	4-Non-ferro	26-Al sheet/extrusion
18	Copper	610,6	4-Non-ferro	29-Cu wire
19	Electronic components	1556,0	6-Electronics	
20	Others	1778,4	7-Misc.	

Table 69: Overview of the Bill of Materials (BOM) for the Base Case air vented tumble dryer

Life Cycle phases -->		PRODUCTION		
Resources Use and Emissions		Material	Manuf.	Total
Materials	unit			
Bulk Plastics	g			4625
TecPlastics	g			3000
Ferro	g			22516
Non-ferro	g			842
Coating	g			0
Electronics	g			1556
Misc.	g			1778
Total weight	g			34317

Table 70: Material distribution for the Base Case air vented tumble dryer

	Average quantity	Base Case	Range
	(in g)	(% mass)	(% mass)
Bulk Plastics	4625	13%	[11-29%]
TecPlastics	3000	9%	[0-6%]
Ferro	22516	66%	[57-80%]
Non-ferro	842	2%	[1-5%]
Coating	0	0%	[0%]
Electronics	1556	5%	[0-7%]
Misc.	1778	5%	[0-15%]
Total	33862	100%	100%

Regarding the Figures presented in the previous tables, the three main categories of material composing an air vented tumble dryer are bulk plastics (13%), Technical plastics (9%) and ferrous metals (66%).

The calculation of the material distribution was performed on each product for which manufacturers provided data (see the range provided in Table 70): the split between the two main types of materials is confirmed.

Distribution

The weight of the Base Case air vented tumble dryer is 37,1 kg (including 2,9 kg of packaging) and it has a packaged volume of 0,38 m³.

Table 71: EcoReport inputs for the distribution phase

	Collected Value	Base Case value
Weight	From 1,27 to 4,6 kg	2,9 kg
Volume	From 0,34 to 0,41 m ³	0,38 m ³

Use

The only resource consumed during the use of a tumble dryer is electricity. On mode, left on mode and off mode consumptions are the averages of the values provided by manufacturers under standard conditions and corrected for real life conditions.

The calculation of the time passed in on-, left on- and off- mode is as follows:

- On-mode duration = annual number of cycles x cycle duration
- Left-on mode duration: 250h88
- Off-mode duration = 365 days x 24 hours – On-mode – Left-on mode

Concerning maintenance data, it was assumed that tumble dryers are the same type of appliances as washing machines and the same values as in lot 14 were used. Thus, the number of kilometres over the product life is 160 km.

⁸⁸ According to manufacturers data

Table 72: EcoReport energy inputs for the Standard Base Case (Air vented)

Pos nr	USE PHASE Description	unit	Subtotals
211	Product Life: in years	13 years	
	Electricity		
212	On-mode: Consumption per hour, cycle, setting, etc.	3,36 kWh	295,68
213	On-mode: No. Of hours, cycles, settings, etc. / year	88 #	
214	Standby-mode: Consumption per hour	0,0025 kWh	0,625
215	Standby-mode: No. Of hours / year	250 #	
216	Off-mode: Consumption per hour	0,00005 kWh	0,41715
217	Off-mode: No. Of hours / year	8343 #	
	TOTAL over Product Life	3,86 MWh (=000 kWh)	65
	Heat		
218	Avg. Heat Power Output	kW	
219	No. Of hours / year	0 hrs.	
220	Type and efficiency (Click & select)	92,0%	66-Electric resistance
	TOTAL over Product Life	0,00 GJ	
	Consumables (excl. spare parts)		material
221	Water	0 m ³ /year	83-Water per m3
222	Auxilliary material 1 (Click & select)	0 kg/ year	85-None
223	Auxilliary material 2 (Click & select)	0 kg/ year	85-None
224	Auxilliary material 3 (Click & select)	0 kg/ year	85-None
	Maintenance, Repairs, Service		
225	No. of km over Product-Life	160 km / Product Life	86
226	Spare parts (fixed, 1% of product materials & manuf.)	343 g	

Table 73: EcoReport energy inputs for the Real Life Base Case (Air vented)

Pos nr	USE PHASE Description	unit	Subtotals
211	Product Life: in years	13 years	
	Electricity		
212	On-mode: Consumption per hour, cycle, setting, etc.	2,01 kWh	311,55
213	On-mode: No. Of hours, cycles, settings, etc. / year	155 #	
214	Standby-mode: Consumption per hour	0,0025 kWh	0,625
215	Standby-mode: No. Of hours / year	250 #	
216	Off-mode: Consumption per hour	0,00005 kWh	0,41655
217	Off-mode: No. Of hours / year	8331 #	
	TOTAL over Product Life	4,06 MWh (=000 kWh)	65
	Heat		
218	Avg. Heat Power Output	kW	
219	No. Of hours / year	0 hrs.	
220	Type and efficiency (Click & select)	92,0%	66-Electric resistance
	TOTAL over Product Life	0,00 GJ	
	Consumables (excl. spare parts)		material
221	Water	0 m ³ /year	83-Water per m3
222	Auxilliary material 1 (Click & select)	0 kg/ year	85-None
223	Auxilliary material 2 (Click & select)	0 kg/ year	85-None
224	Auxilliary material 3 (Click & select)	0 kg/ year	85-None
	Maintenance, Repairs, Service		
225	No. of km over Product-Life	160 km / Product Life	86
226	Spare parts (fixed, 1% of product materials & manuf.)	343 g	

V.2.4 BOM and Inventory Data Collection for air condenser tumble dryers

BOM

The BOM is given for the Base Case air condenser tumble dryer. The data provided by the manufacturers can only be classified by material type and not by subassembly. The resulting BOM is presented in the following table.

Table 74: EcoReport material input table for the Base Case air condenser tumble dryer

Nr		Product name	Date	Author
		BASE CASE AIR CONDENSED TUMBLE DRYER		CODDE

Pos nr	MATERIALS Extraction & Production Description of component	Weight in g	Category Click & select	Material or Process select Category first !
1	Polystyrene	377,8	1-BlkPlastics	5-PS
2	Polypropylene	7714,5	1-BlkPlastics	4-PP
3	ABS	2117,0	1-BlkPlastics	10-ABS
4	PA	197,6	2-TecPlastics	11-PA 6
5	POM	85,7	2-TecPlastics	
6	PMMA	28,3	2-TecPlastics	13-PMMA
7	PC	23,3	2-TecPlastics	12-PC
8	PVC	115,3	1-BlkPlastics	8-PVC
9	Other	2475,0	1-BlkPlastics	
10	EPDM - Rubber	330,3	2-TecPlastics	15-Rigid PUR
11	Silicone	13,3	2-TecPlastics	15-Rigid PUR
12	Steel	13208,2	3-Ferro	22-St tube/profile
13	Stainless steel	2295,0	3-Ferro	25-Stainless 18/8 coil
14	Galvanized steel	4381,7	3-Ferro	21-St sheet galv.
15	Paint steel	3588,3	3-Ferro	22-St tube/profile
16	Aluminium	653,5	4-Non-ferro	26-Al sheet/extrusion
17	Copper	710,3	4-Non-ferro	29-Cu wire
18	Electronic components	1987,7	6-Electronics	
19	Others	1856,3	7-Misc.	
20				

Table 75: Overview of the Bill of Materials (BOM) for the Base Case air condenser tumble dryer

Life Cycle phases -->		PRODUCTION		
Resources Use and Emissions		Material	Manuf.	Total
	Materials			
	unit			
1	Bulk Plastics	g		12800
2	TecPlastics	g		679
3	Ferro	g		23473
4	Non-ferro	g		1364
5	Coating	g		0
6	Electronics	g		1988
7	Misc.	g		1856
	Total weight	g		42159

Table 76: Material distribution for the Base Case air condenser tumble dryer

	Materials (in g)	Base Case (% mass)	Range (% mass)
Bulk Plastics	12 800	30%	[16-38%]
TecPlastics	679	2%	[0-3%]
Ferro	23 473	56%	[46-73%]
Non-ferro	1 364	3%	[1-7%]
Coating	0	0%	[0%]
Electronics	1 988	5%	[0-7%]
Misc.	1 856	4%	[0-13%]
Total	42 159	100%	100%

Regarding the Figures presented in the previous tables, the two main categories of materials composing a condenser tumble dryer are bulk plastics (30%) and ferrous metals (56%).

The calculation of the material distribution was performed on each product for which manufacturers provided data (see the range provided in Table 76 the split between the two main types of materials is confirmed).

Moreover, it must be highlighted that the part of plastics is more important than in air vented tumble dryers.

Distribution

The weight of the Base Case Condenser tumble dryer is 45 kg (including 2,9 kg of packaging) and it has a packaged volume of 0,38 m³.

Table 77: EcoReport inputs for the distribution phase

	Collected Value	Base Case value
Weight	From 1,27 to 4,6 kg	2.9 kg
Volume	From 0,35 to 0,41 m ³	0,38 m ³

Use

The only resource consumed during the use of a tumble dryer is electricity. On mode, left on mode and off mode consumptions are the averages of the values provided by manufacturers under standard conditions and corrected for real life conditions.

Concerning mode duration and maintenance data, the same hypotheses as in part 3.3 are considered.

Table 78: EcoReport energy inputs for the Standard Base Case (Condenser)

Pos nr	USE PHASE Description	unit	Subtotals
211	Product Life, in years	13 years	
	Electricity		
212	On-mode: Consumption per hour, cycle, setting, etc.	3,6 kWh	316,8
213	On-mode: No. Of hours, cycles, settings, etc. / year	88 #	
214	Standby-mode: Consumption per hour	0,0025 kWh	0,625
215	Standby-mode: No. Of hours / year	250 #	
216	Off-mode: Consumption per hour	0,00005 kWh	0,41785
217	Off-mode: No. Of hours / year	8357 #	
	TOTAL over Product Life	4,13 MWh (=000 kWh)	65
	Heat		
218	Avg. Heat Power Output	0 kW	
219	No. Of hours / year	0 hrs.	
220	Type and efficiency (Click & select)		85-not applicable
	TOTAL over Product Life	0,00 GJ	
	Consumables (excl. spare parts)		material
221	Water	0 m ³ /year	83-Water per m3
222	Auxilliary material 1 (Click & select)	0 kg/ year	85-None
223	Auxilliary material 2 (Click & select)	0 kg/ year	85-None
224	Auxilliary material 3 (Click & select)	0 kg/ year	85-None
	Maintenance, Repairs, Service		
225	No. of km over Product-Life	160 km / Product Life	86
226	Spare parts (fixed, 1% of product materials & manuf.)	422 g	

Table 79: EcoReport energy inputs for the Real Life Base Case (Condenser)

Pos nr	USE PHASE Description	unit	Subtotals
211	Product Life, in years	13 years	
	Electricity		
212	On-mode: Consumption per hour, cycle, setting, etc.	2,17 kWh	33,25
213	On-mode: No. Of hours, cycles, settings, etc. / year	153 #	
214	Standby-mode: Consumption per hour	0,0025 kWh	0,625
215	Standby-mode: No. Of hours / year	250 #	
216	Off-mode: Consumption per hour	0,00005 kWh	0,41775
217	Off-mode: No. Of hours / year	8355 #	
	TOTAL over Product Life	4,35 MWh (=000 kWh)	65
	Heat		
218	Avg. Heat Power Output	0 kW	
219	No. Of hours / year	0 hrs.	
220	Type and efficiency (Click & select)		85-not applicable
	TOTAL over Product Life	0,00 GJ	
	Consumables (excl. spare parts)		material
221	Water	0 m ³ /year	83-Water per m3
222	Auxilliary material 1 (Click & select)	0 kg/ year	85-None
223	Auxilliary material 2 (Click & select)	0 kg/ year	85-None
224	Auxilliary material 3 (Click & select)	0 kg/ year	85-None
	Maintenance, Repairs, Service		
225	No. of km over Product-Life	0 km / Product Life	86
226	Spare parts (fixed, 1% of product materials & manuf.)	422 g	

V.3 Base Case Environmental Impact Assessment (Subtask 5.3)

The assessment of the tumble dryers' environmental impacts is made according to a methodology developed by VHK for the European Commission.

The impact indicators presently used are indicators selected by the Commission.

Before beginning the life cycle impact analysis, a short reminder of these indicators is presented below.

Concerning general indicators, 7 indicators are considered:

- Total Gross Energy requirement, in MJ primary
- Electricity, in MJ primary
- Feedstock energy, in MJ primary
- Process water, in litre
- Cooling water, in litre
- Hazardous Solid Waste, in g
- Non-Hazardous Waste, in g

Concerning emissions to air, 7 indicators are considered:

- GWP, Global Warming Potential, in CO₂ equivalent
- ODP, Ozone Depletion Potential, in CFC-11 equivalent
- AP, Acidification Potential in SO₂ equivalent
- POP, Persistent Organic Pollutants, in I-Teq
- VOC, Volatile Organic Compounds, in mg
- Heavy Metals, in Pb-equivalent
- PAHs, Polycyclic Aromatic Hydrocarbons

Concerning emissions to water, 2 indicators are considered:

- EUP, Eutrophication Potential, in PO₄ or P₂O₅ equivalent
- Heavy metal in Pb-equivalent

V.3.1 Environmental impact assessment of the Base Case air vented tumble dryer using the EuP-EcoReport

Table 80 shows the results of the environmental impact assessment for the Base Case air vented tumble dryer under real life conditions.

For both Base Cases (STBC and RLBC), an average use phase duration of 13 years is assumed.

Table 80: EcoReport environmental assessment results under real life conditions (RLBC Air vented)

Life Cycle phases --> Resources Use and Emissions		PRODUCTION			DISTRIBUITION	USE	END-OF-LIFE*		TOTAL	
		Material	Manuf.	Total			Disposal	Recycl.		Total
Materials		unit								
1 Bulk Plastics	g			4625			139	4486	4625	0
2 TecPlastics	g			3000			90	2910	3000	0
3 Ferro	g			22516			1126	21390	22516	0
4 Non-ferro	g			842			42	800	842	0
5 Coating	g			0			0	0	0	0
6 Electronics	g			1556			1556	0	1556	0
7 Misc.	g			1778			89	1689	1778	0
Total weight	g			34317			3042	31275	34317	0
Other Resources & Waste		see note!								
8 Total Energy (GER)	MJ	1191	436	1626	486	43070	181	388	-207	44975
9 of which, electricity (in primary MJ)	MJ	156	250	414	1	42673	0	31	-30	43058
10 Water (process)	ltr	265	4	269	0	2847	0	20	-20	3096
11 Water (cooling)	ltr	559	110	677	0	113790	0	169	-169	114299
12 Waste, non-haz./landfill	g	35544	1609	37153	261	49844	2127	119	2009	89266
13 Waste, hazardous/ incinerated	g	38	0	38	5	984	229	19	211	1238
Emissions (Air)										
14 Greenhouse Gases in GWP100	kg CO2 eq.	72	24	96	30	1893	10	9	4	2024
15 Ozone Depletion, emissions	mg R-11 eq.	negligible								
16 Acidification, emissions	g SO2 eq.	505	105	610	91	11023	34	25	10	11734
17 Volatile Organic Compounds (VOC)	g	3	0	3	7	22	2	0	1	33
18 Persistent Organic Pollutants (POP)	ng i-Teq	314	18	332	1	283	15	0	15	632
19 Heavy Metals	mg Ni eq.	512	43	556	13	821	49	0	49	1439
PAHs	mg Ni eq.	79	0	79	17	168	0	2	-2	262
20 Particulate Matter (PM, dust)	g	64	16	80	1094	1647	396	3	393	3215
Emissions (Water)										
21 Heavy Metals	mg Hg/20	367	0	367	0	279	11	0	11	657
22 Eutrophication	g PO4	10	0	10	0	1	1	1	0	12
23 Persistent Organic Pollutants (POP)	ng i-Teq	negligible								

Energy consumption distribution over the whole life cycle

First, a focus is made on the energy consumption and particularly on the influence of the drying conditions (Standard Base Case (STBC) against Real Life Based Case (RLBC)).

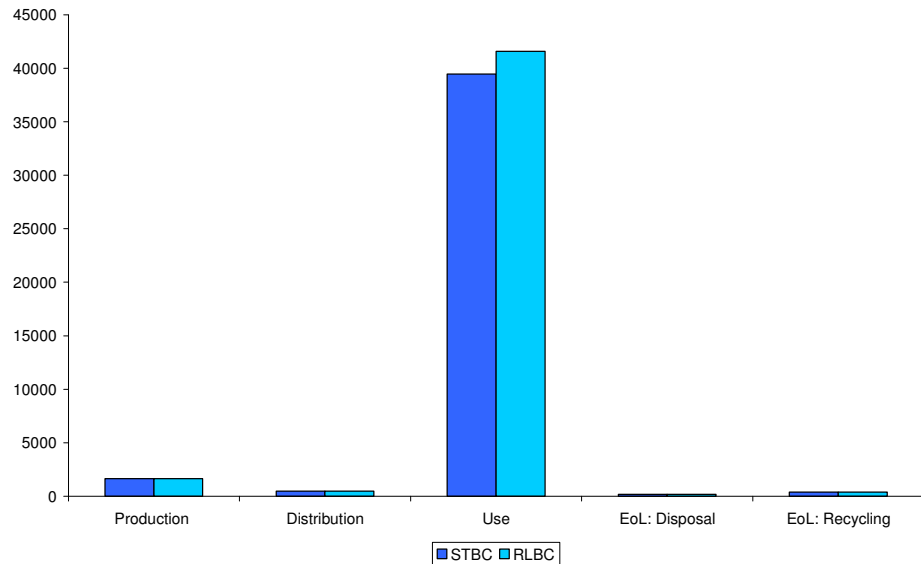

Figure 130: Energy consumption over all life cycle phases (GER in MJ) (STBS and RLBC Air vented)

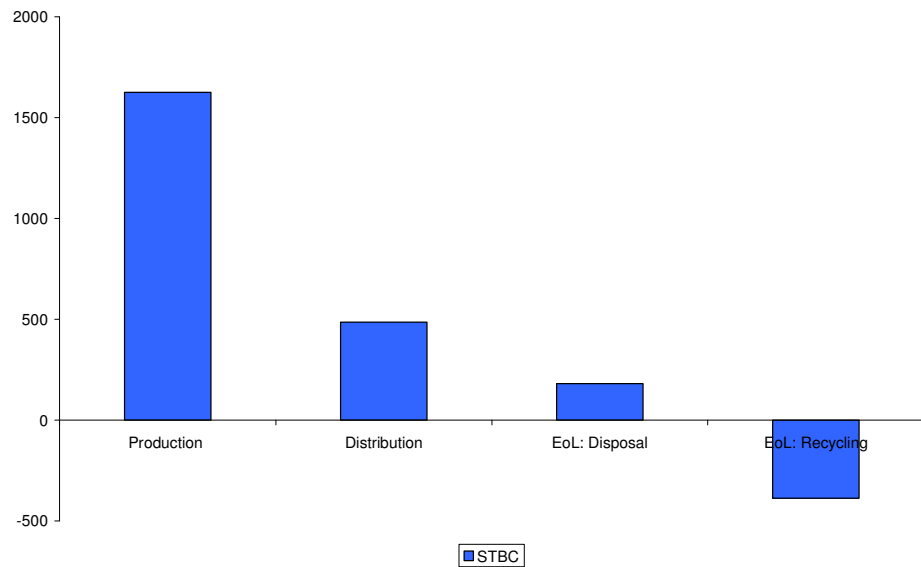

Figure 131: Energy consumption over the life cycle phases (excluding the use phase) (STBC Air vented)

On Figure 130 and Figure 131, the total energy consumption (GER) is taken as the reference: it is shown that the use phase is the main contributor to the overall impact. Indeed, this phase is responsible for 96% of the total energy consumption. The distribution phase (1% of the overall impact) and the End of life phase (0,4%) have a very low contribution.

On 134, the influence of the Base Case choice is highlighted: in real life conditions, energy consumption is more important. A difference of 5% in energy consumption is observed. Indeed, no matter of the loading, the appliance has always to be heated and a constant heat quantity is to attribute per drying cycle.

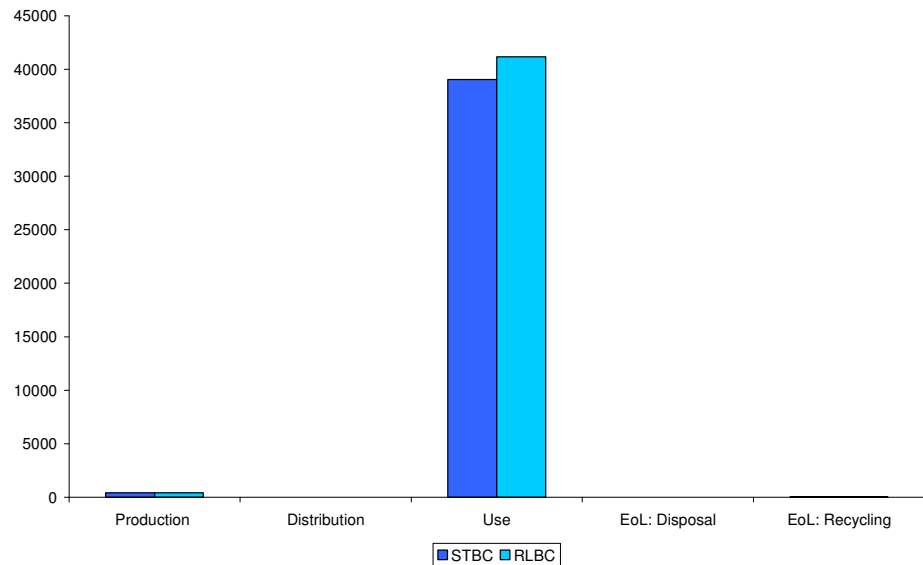

Figure 132: Electricity consumption over all life cycle phases (STBC and RLBC Air vented)

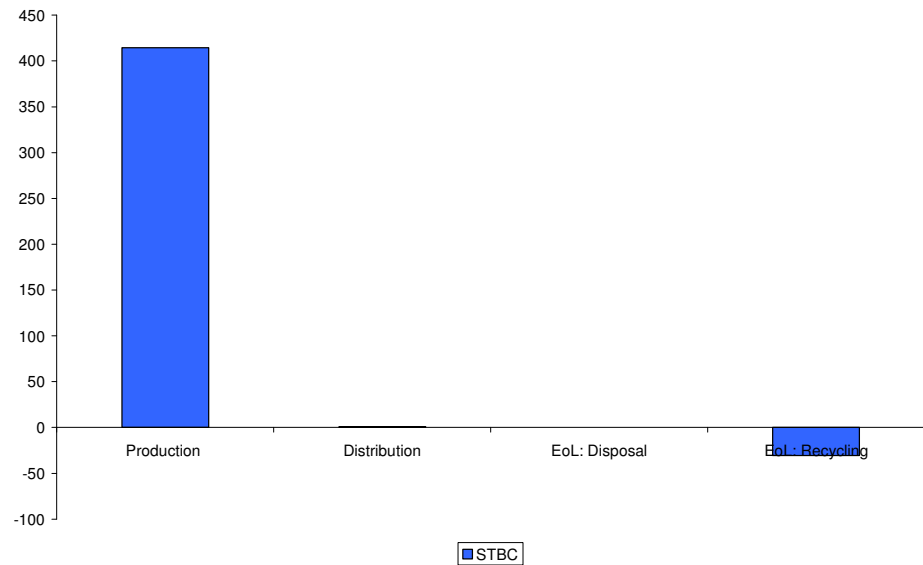

Figure 133: Electricity consumption over the life cycle phases (excluding the use phase) (STBC Air vented)

Influence of the different life cycle phases on the air and water impact indicators

Concerning atmospheric pollution and water consumption, the most impacting phase is the use phase (its relative impact, compared to other phases, is between 45% and 95%). Indeed, the type of energy source (especially for electricity) has a great impact on the pollution type and quantity. For information, it is generally considered that in Europe, around 20% of the energy is generated by coal, 20% by gas, 30% by nuclear, and 15% is hydroelectricity. On the contrary, the production phase has a more important relative impact on heavy metal emissions in water and on water eutrophication.

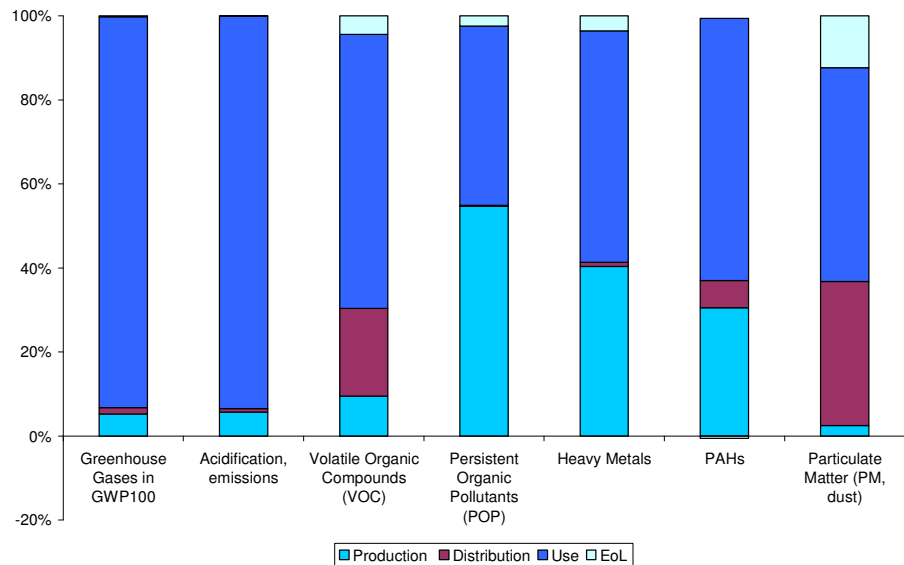

Figure 134: Relative impact of the life cycle phases on air pollution (RLBC Air vented)

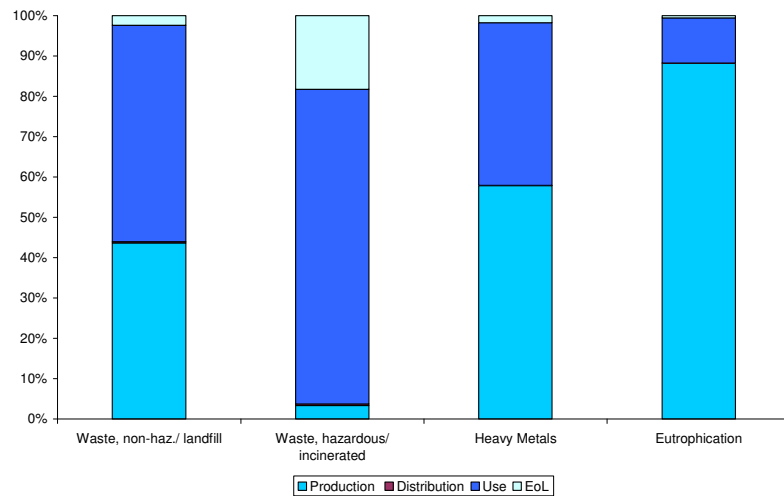

Figure 135: Relative impact of the life cycle phases on waste production and water pollution (RLBC Air vented)

Influence of the manufacturing phase on the environmental impact assessment

Considering that the production has a significant influence on the environment, the main contributors to the most significant impacts were looked into:

Steel

Steel accounts for around 70% of the product composition and up to 50% of the impact on air and water.

The following distribution between the different types of steels was considered for the Base Case air vented dryer defined:

	Weight	Percentage
Ferrous metals: Total	22,5	100%
Steel	12,2	54%
Galvanized sheet steel	2,856	13%
Painted sheet steel	3,76	17%
Stainless steel	3,776	17%

In order to give an idea of the influence of the type of steel on the environmental impact, Figure 136 shows the relative impacts of the different steels (the reference chosen being stainless steel)

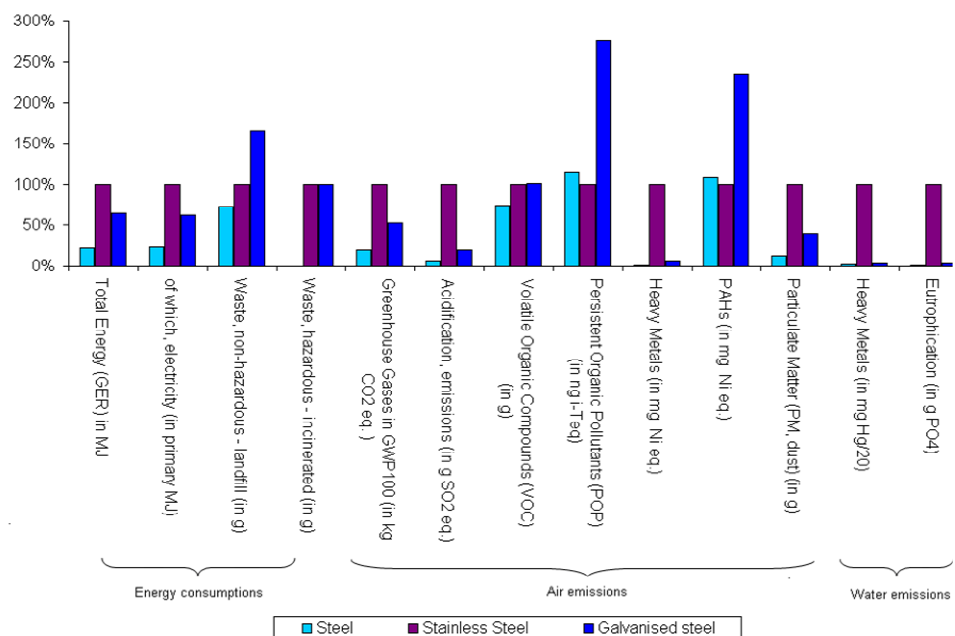

Figure 136: Relative impact of the different types of steel

Polypropylene (PP) and ABS

PP and ABS account for 16% of the product composition. They are responsible for around 40% of the energy consumption during the production phase and for up to 10% of the impact relating to 7 impact indicators out of 10.

Copper

Copper represents only 2% of the product composition but is responsible for 8% of the global energy consumption during the manufacturing phase, for up to 5% of the global warming potential, for up to 10% of the heavy metal emissions in water, as well as of the PAC emissions and finally for up to 30% of the air acidification potential and waste production.

It can be noticed that aluminium manufacturing is responsible for the discharge of PAH (Polycyclic Aromatic Hydrocarbons), a detrimental substance for human health.

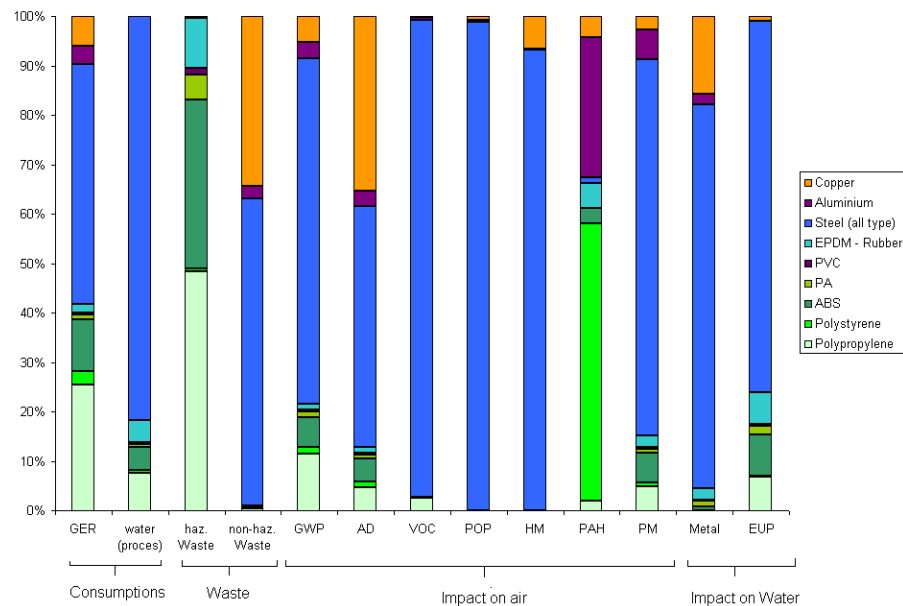

Figure 137: Contribution of the main materials to air and water pollution during the production phase

Sensitivity analysis for compact air vented tumble dryers

A specific analysis was made on compact air vented dryers. Due to the fact that this analysis is only a sensitivity analysis, the assessment is relative to one representative compact air vented dryer. Moreover, since no information relating to consumer behaviour is available, the analysis considers only standard conditions.

In order to evaluate the impacts of the compact air vented tumble dryer, the following parameters and data have been taken into account in the calculation:

- Product life cycle: 13 years
- Energy efficiency = D Class (C not available)
- Consumption per cycle: 1.8 kWh/cycle under standard conditions
- Load capacity: 3 kg
- Cycles per year: 175 under standard conditions
- Under real life conditions: no data available

The material distribution is presented in Table 81

Table 81: EcoReport environmental assessment results under real life conditions (RLBC Compact Air vented)

Nr	Life cycle Impact per product:				Date	Author					
0	Compact air vented tumble dryer (Front, 3kg) Standard				0	vhk					
Life Cycle phases -->											
Resources Use and Emissions	PRODUCTION			DISTRIBUTION	USE	END-OF-LIFE*		TOTAL			
	Material	Manuf.	Total			Disposal	Recycl.		Total		
Materials											
	unit										
1	Bulk Plastics	g		1520			106	1414	1520	0	
2	TecPlastics	g		417			29	388	417	0	
3	Ferro	g		19540			977	18563	19540	0	
4	Non-ferro	g		1375			69	1306	1375	0	
5	Coating	g		6			0	6	6	0	
6	Electronics	g		0			0	0	0	0	
7	Misc.	g		233			12	221	233	0	
	Total weight	g		23091			193	21898	23091	0	
<i>see note!</i>											
Other Resources & Waste											
						debit	credit				
8	Total Energy (GER)	MJ	1040	443	1484	431	43540	100	98	2	45457
9	of which, electricity (in primary MJ)	MJ	79	255	334	1	43143	0	7	-7	43471
10	Water (process)	ltr	37	3	40	0	2876	0	5	-5	2912
11	Water (cooling)	ltr	287	103	395	0	115044	0	40	-40	115399
12	Waste, non-haz / landfill	g	51422	2106	53528	235	50554	1421	28	1393	105709
13	Waste, hazardous/ incinerated	g	19	0	19	5	994	136	4	131	1149
Emissions (Air)											
14	Greenhouse Gases in GWP100	kg CO2 eq.	73	25	98	27	1913	7	2	5	2043
15	Ozone Depletion, emissions	mg R-11 eq.					negligible				
16	Acidification, emissions	g SO2 eq.	452	110	561	81	11144	17	6	10	11797
17	Volatile Organic Compounds (VOC)	g	3	0	3	6	23	1	0	1	32
18	Persistent Organic Pollutants (POP)	ng I-Teq	518	54	572	1	288	10	0	10	871
19	Heavy Metals	mg Ni eq.	234	127	361	12	827	28	0	28	1228
	PAHs	mg Ni eq.	86	0	86	15	169	0	0	0	270
20	Particulate Matter (PM, dust)	g	71	17	88	958	1649	169	1	168	2863
Emissions (Water)											
21	Heavy Metals	mg Hg/20	175	0	175	0	280	7	0	7	463
22	Eutrophication	g PO4	4	0	4	0	1	0	0	0	6
23	Persistent Organic Pollutants (POP)	ng I-Teq					negligible				

Thanks to the results of the environmental assessment presented in Table 81, the distribution of the impacts over the whole life cycle of the product can be analysed (see 142).

As for the standard air vented tumble dryers Base Case, the two most impacting phases are:

- The use phase, which is preponderant concerning energy consumption, greenhouse gas emissions, air acidification and VOC emissions.
- The production phase, which is responsible for the majority of the impact on water quality, of the POP emissions and of the heavy metal air emissions.

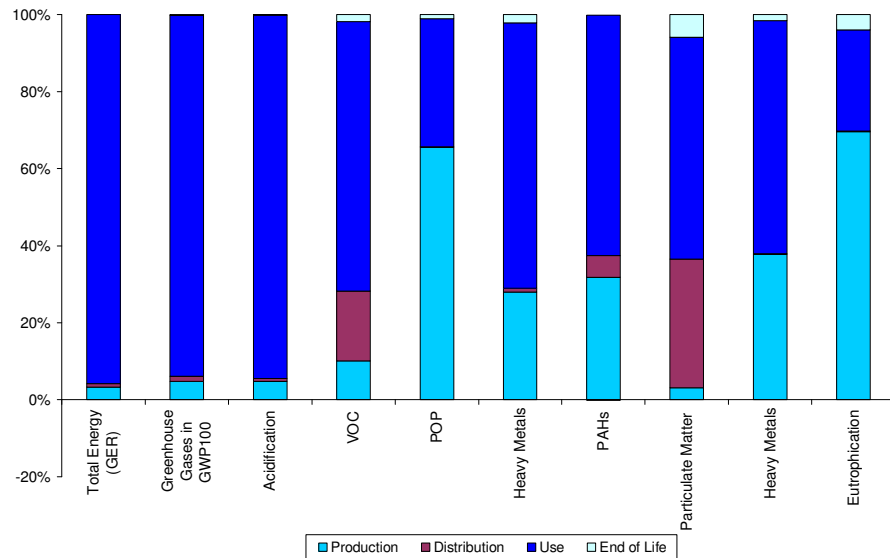

Figure 138: Relative contribution of the life cycle phases on the environmental impacts under standard conditions (Compact air vented)

Finally, the impacts of the Base Case air vented tumble dryer were compared with those of the compact air vented tumble dryer (see 143).

The comparison shows that the compact dryer has a lower impact relating to 5 indicators and a higher impact relating to 5 indicators. First, this can be explained by a more important electricity consumption. Indeed, only data for a D class compact tumble dryer are available. Secondly, a compact dryer has a lower weight, which explains the lower impact on indicators where the production has a higher influence. Finally, the composition of the dryer is different: there is more aluminium, consequently more impact on the PAH emissions. However, it is recommended to be cautious with those data because; this comparison is made between average values for the Base case air vented dryer and absolute data for the compact dryer.

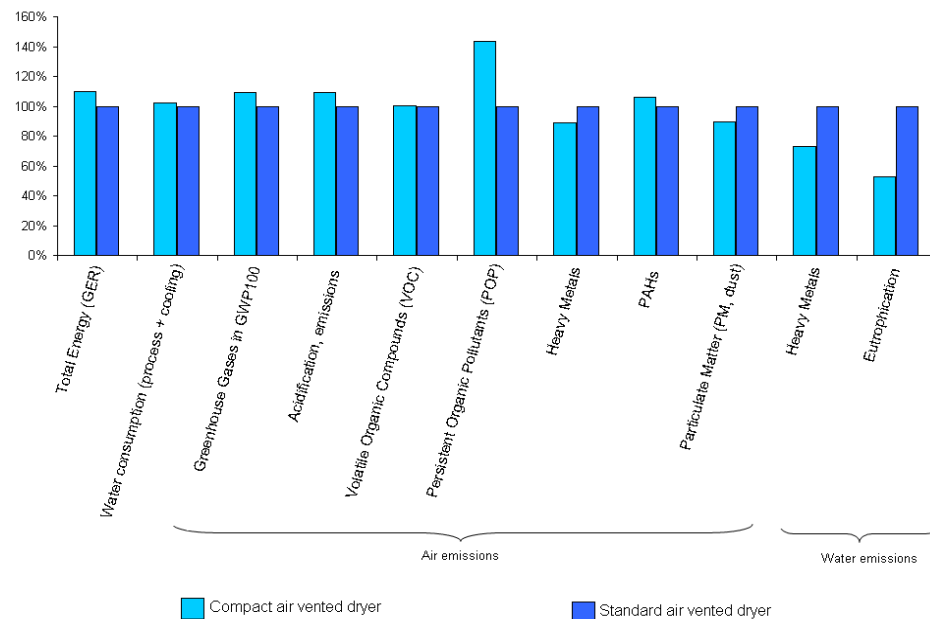

Figure 139: Comparison between the Base Case air vented dryer and the compact air vented tumble dryer

V.3.2 Environmental impact assessment of the Base Case air condenser tumble dryer using the EuP EcoReport

Table 82 shows the results of the environmental impact assessment for the Base Case air condenser tumble dryer used under real life conditions.

As previously, an average use phase duration of 13 years is assumed for both Base Cases (STBC and RLBC),

Table 82: EcoReport environmental assessment results under real life conditions (RLBC Air condenser)

Life Cycle phases -->	Resources Use and Emissions	PRODUCTION			DISTRIBUITION	USE	END-OF-LIFE*		TOTAL		
		Material	Manuf.	Total			Disposal	Recycl.		Total	
Materials		unit									
1	Bulk Plastics	g			12800		384	12416	12800	0	
2	TecPlastics	g			679		20	658	679	0	
3	Ferro	g			23473		1174	22300	23473	0	
4	Non-ferro	g			1364		68	1296	1364	0	
5	Coating	g			0		0	0	0	0	
6	Electronics	g			1988		1988	0	1988	0	
7	Misc.	g			1856		93	1763	1856	0	
	Total weight	g			42159		3727	38433	42159	0	
Other Resources & Waste		see note!									
8	Total Energy (GER)	MJ	1652	683	2336	567	45654	256	685	-429	48128
9	of which, electricity (in primary MJ)	MJ	192	407	599	1	45637	0	54	-54	46183
10	Water (process)	ltr	258	6	264	0	3045	0	36	-36	3273
11	Water (cooling)	ltr	901	188	1089	0	121693	0	298	-298	122485
12	Waste, non-haz / landfill	g	40680	2403	43083	300	53337	2627	210	2417	99137
13	Waste, hazardous/ incinerated	g	67	0	67	6	1052	405	33	372	1498
Emissions (Air)											
14	Greenhouse Gases in GWP100	kg CO2 eq	88	38	126	35	1993	19	16	3	2156
15	Ozone Depletion, emissions	mg R-11 eq.	negligible								
16	Acidification, emissions	g SO2 eq.	582	165	747	106	11757	51	43	8	12618
17	Volatile Organic Compounds (VOC)	g	3	0	3	8	17	2	0	2	31
18	Persistent Organic Pollutants (POP)	ng i-Teq	339	20	359	2	303	18	0	18	681
19	Heavy Metals	mg Ni eq.	441	46	487	15	788	68	0	68	1358
	PAHs	mg Ni eq.	127	0	127	19	91	0	3	-3	235
20	Particulate Matter (PM, dust)	g	77	25	102	1299	252	618	6	613	2266
Emissions (Water)											
21	Heavy Metals	mg Hg/20	359	0	359	0	298	14	0	14	672
22	Eutrophication	g PO4	11	0	11	0	2	1	1	0	12
23	Persistent Organic Pollutants (POP)	ng i-Teq	negligible								

Distribution of the energy consumption over the life cycle of the product

By considering 144 and 145, it appears that the use phase is the most energy-consuming phase, as previously shown for air vented tumble dryers. The production, distribution and end of life phases have less influence.

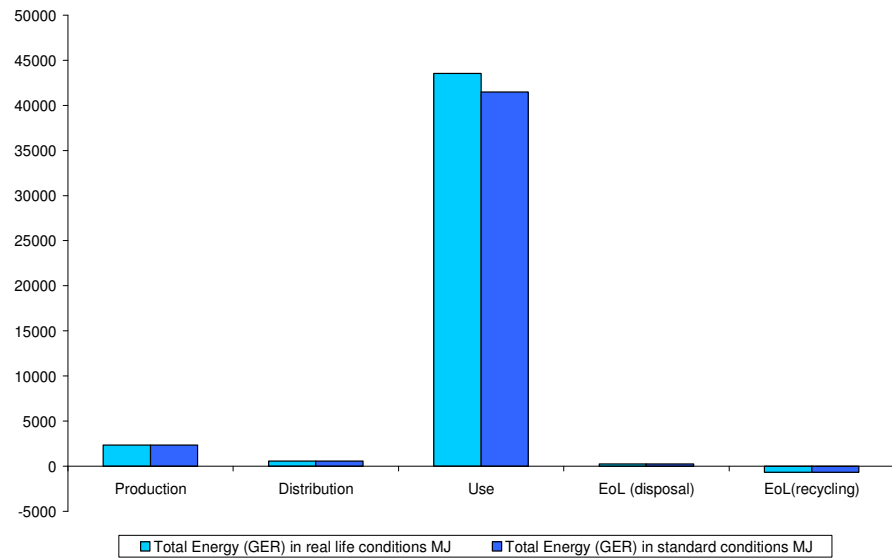

Figure 140: Energy consumption over all life cycle phases (STBC and RLBC Condenser)

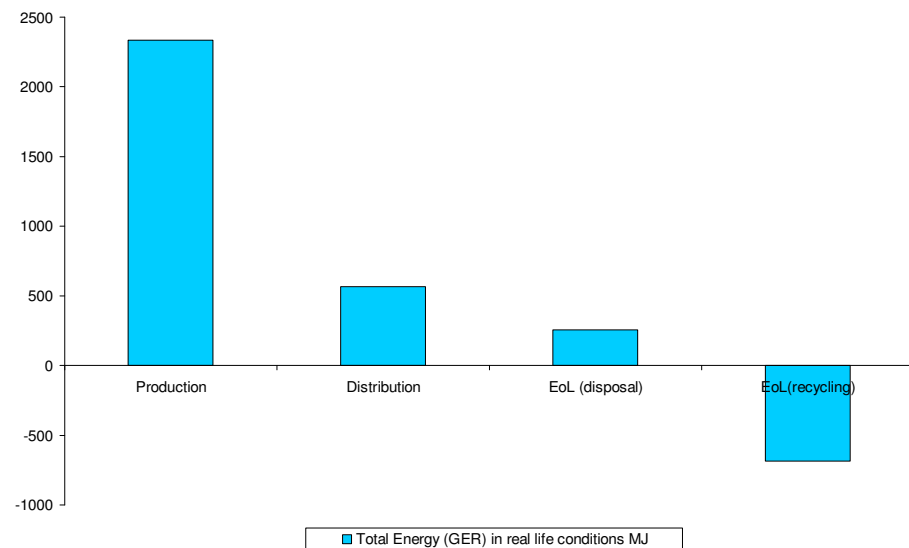

Figure 141: Energy consumption over the different life cycle phases (excluding the use phase) (RLBC Condenser)

Concerning the use phase, most of the energy consumed is electricity. On the contrary, during the production phase, the energy to process material mostly comes from gas and coal.

It can be noted that the energy used in real life conditions (RLBC) is more important than in standard conditions (STBC). A difference of 4% in use phase consumption is observed. This is due to the loading and annual number of cycles. Indeed, there is a fixed energy consumption for heating up the appliance itself (thus not depending on the load).

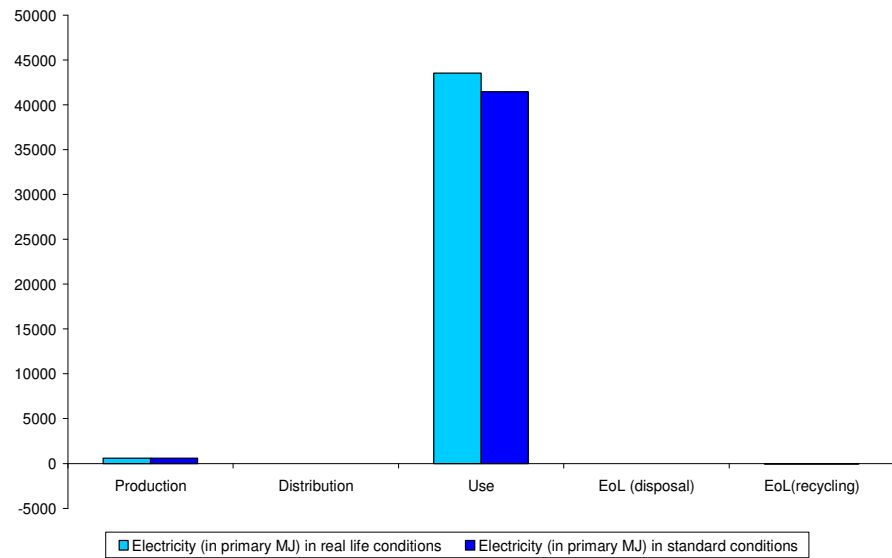

Figure 142: Electricity consumption over all life cycle phases (STBC and RLBC Condenser)

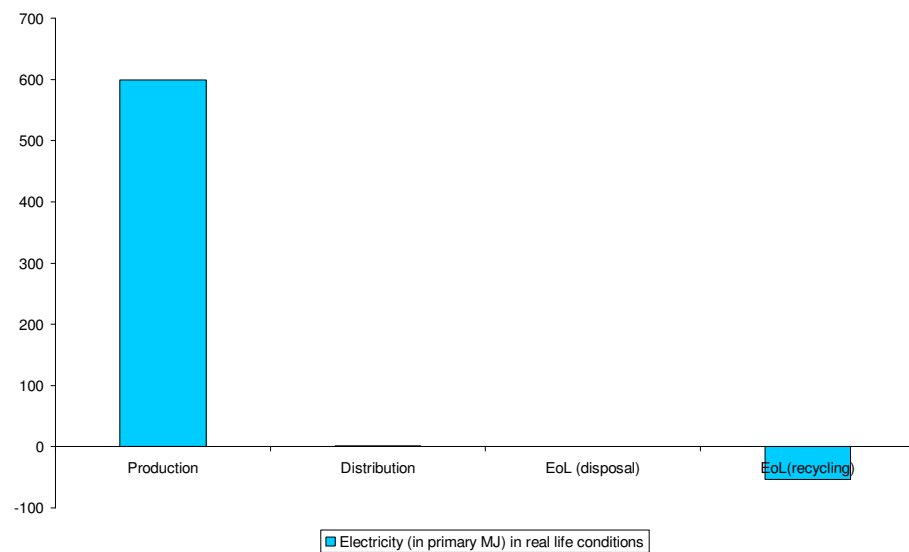

Figure 143: Electricity consumption over the different life cycle phases (excluding the use phase) (RLBC Condenser)

Influence of the different life cycle phases on the air and water impact indicators

Relating to air pollution, the use phase is the most impacting phase on 4 impact indicators out of 7, whereas the production phase is the most impacting phase on 2 indicators. Concerning the use phase, energy generation is responsible for the impact on air pollution.

It should be stressed that the distribution phase has a significant impact on particulate emissions and Volatile Organic Compound emissions.

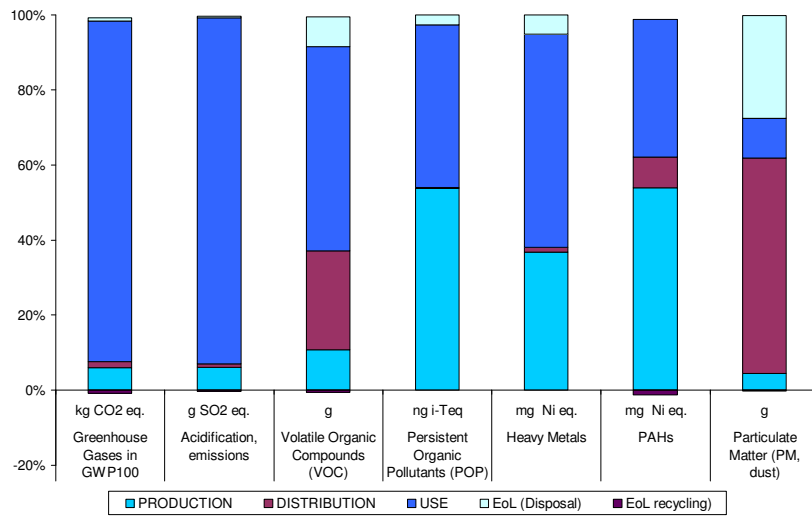

Figure 144: Relative contribution of the life cycle phases on the environmental impacts under standard conditions (RLBC Condenser)

Concerning the two water impact indicators, the manufacturing phase is responsible for the majority of the impact. Moreover, the production phase is responsible for non hazardous waste production.

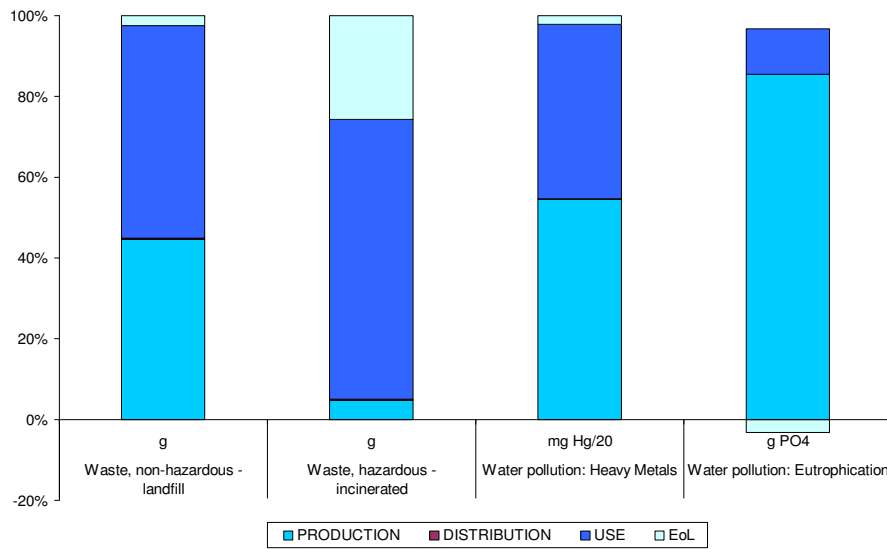

Figure 145: Relative impact of the life cycle phases on water pollution and on waste production (RLBC Condenser)

Influence of the manufacturing phase on the environmental assessment

Considering that the production has a significant influence on environment, the main contributors to the most significant environmental impacts were looked into.

Steel

Steel accounts for 55% of the product mass and is the most impacting material concerning 9 indicators out of 11.

The following distribution between the different types of steel was considered:

	Weight	Percentage
Ferrous metals: Total weight	20	100%
<i>Steel</i>	13	63%
<i>Galvanized sheet steel</i>	3	12%
<i>Painted sheet steel</i>	4	18%
<i>Stainless steel</i>	1	7%

In order to give an idea of the influence of the steel type on environmental impact, Figure 136 shows the relative impact of the different steels (the reference chosen being stainless steel)

Polypropylene (PP) and ABS

PP and ABS constitute 19% of the product composition and are responsible for the majority of rest of the impact. Moreover, it should be noticed that polymer production is responsible for the overall hazardous waste production.

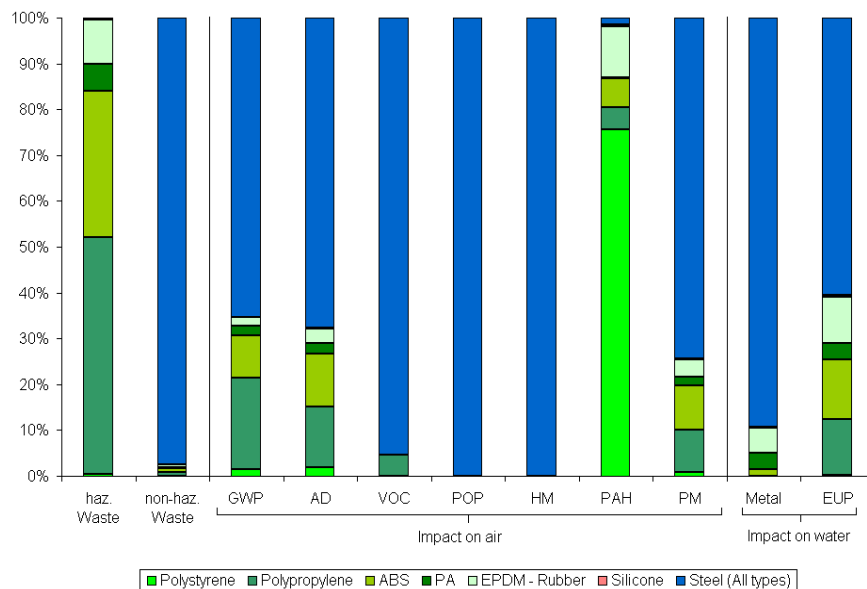

Figure 146: Contribution of the main materials to air and water pollution during the production phase

Sensitivity analysis for top condenser tumble dryers

A specific analysis is made on top loading condenser tumble dryers, relative to one representative top air condenser dryer. Since no information relating to consumer behaviour with this type of dryers is available, the analysis is made only under standard conditions.

In order to evaluate the environmental impacts of the top air condenser tumble dryer, the following parameters and data have been taken into account:

- Product life cycle: 13 years
- Energy efficiency: C Class
- Load capacity: 5 kg
- Consumption per cycle: 3.49 kWh/cycle
- Cycles per year under standard conditions: 10589

Table 83: EcoReport environmental assessment results under standard conditions (Top air condenser)

Nr	Life cycle impact per product:				Date	Author				
0	Products					0 v/hk				
Life Cycle phases -->	PRODUCTION			DISTRI- BUTION	USE	END-OF-LIFE*		TOTAL		
Resources Use and Emissions	Material	Manuf.	Total			Disposal	Recycl.	Total		
Materials										
	unit									
1 Bulk Plastics	g		9020			631	8389	9020	0	
2 TecPlastics	g		1270			89	1181	1270	0	
3 Ferro	g		23340			1167	22173	23340	0	
4 Non-ferro	g		2400			120	2280	2400	0	
5 Coating	g		0			0	0	0	0	
6 Electronics	g		990			990	0	990	0	
7 Misc.	g		0			0	0	0	0	
Total weight	g		37020			2997	34023	37020	0	
<i>see note!</i>										
Other Resources & Waste										
8 Total Energy (GER)	MJ	1680	571	2232	486	50185	237	521	-284	52619
9 of which, electricity (in primary MJ)	MJ	167	339	506	1	50168	0	39	-39	50636
10 Water (process)	ltr	68	5	73	0	3345	0	26	-26	3392
11 Water (cooling)	ltr	737	156	892	0	133777	0	215	-215	134454
12 Waste, non-haz./landfill	g	50039	2087	52126	261	58682	2300	151	2149	113218
13 Waste, hazardous/ incinerated	g	59	0	59	5	1156	721	24	697	1917
Emissions (Air)										
14 Greenhouse Gases in GWP100	kg CO2 eq.	90	32	122	30	2190	17	13	4	2347
15 Ozone Depletion, emissions	mg R-11 eq.	negligible								
16 Acidification, emissions	g SO2 eq.	587	138	726	91	12924	45	33	12	13753
17 Volatile Organic Compounds (VOC)	g	3	0	3	7	19	2	0	2	31
18 Persistent Organic Pollutants (POP)	ng I-Teq	387	22	409	1	333	16	0	16	759
19 Heavy Metals	mg Ni eq.	125	53	178	13	862	64	0	64	1117
PAHs	mg Ni eq.	240	0	240	17	101	0	2	-2	356
20 Particulate Matter (PM, dust)	g	77	21	98	1094	277	516	4	512	1981
Emissions (Water)										
21 Heavy Metals	mg Hg/20	250	0	250	0	326	15	0	15	591
22 Eutrophication	g PO4	5	0	5	0	2	1	1	0	7
23 Persistent Organic Pollutants (POP)	ng I-Teq	negligible								

⁸⁹ 155 x 3.4 kg / 5kg = 105 cycles/year

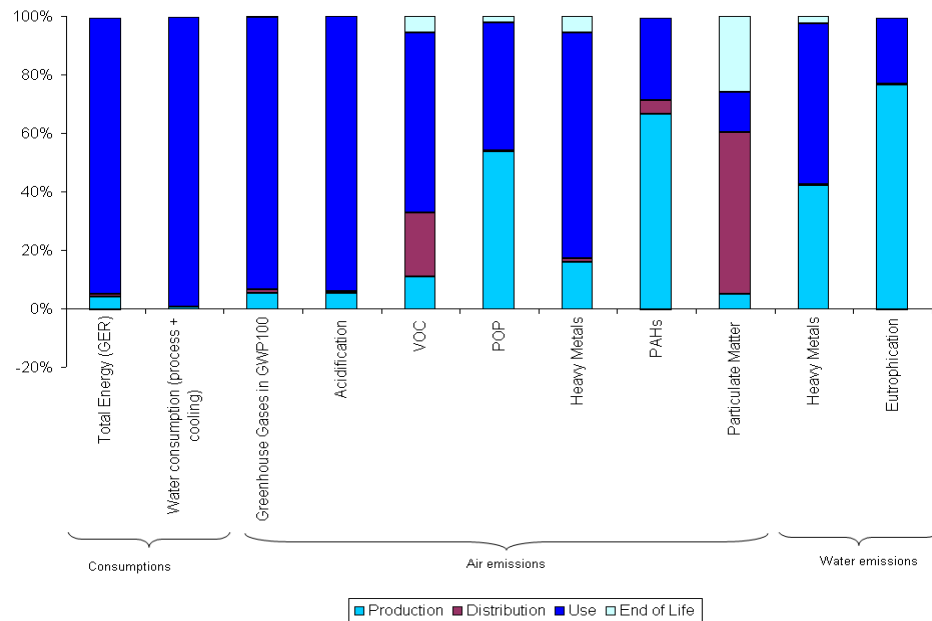

Figure 147: Relative contribution of the life cycle phases on the environmental impacts under standard conditions (STBC Top air condenser)

The impact distribution on the overall life cycle is presented on Figure 137. As described previously in other cases, the most impacting life cycle phases are:

- The use phase, which is the most impacting phase concerning 7 impact indicators out of 11. The impact on water and on air is more important than in the other cases.
- The production phase, which has a significant impact on water pollution and on PAH and POP emissions. Please note that PAH emissions are mainly due to the use of aluminium.

Finally, a comparison is made between the LCA of a front air condenser tumble dryer and that of a top condenser tumble dryer. It appears that the top condenser dryer is more impacting than the front loading model concerning 7 impacts out of 11. But, it is recommended to be cautious with those data since this comparison is made between average values for the Base Case (which is a front dryer) and absolute values for the top dryer.

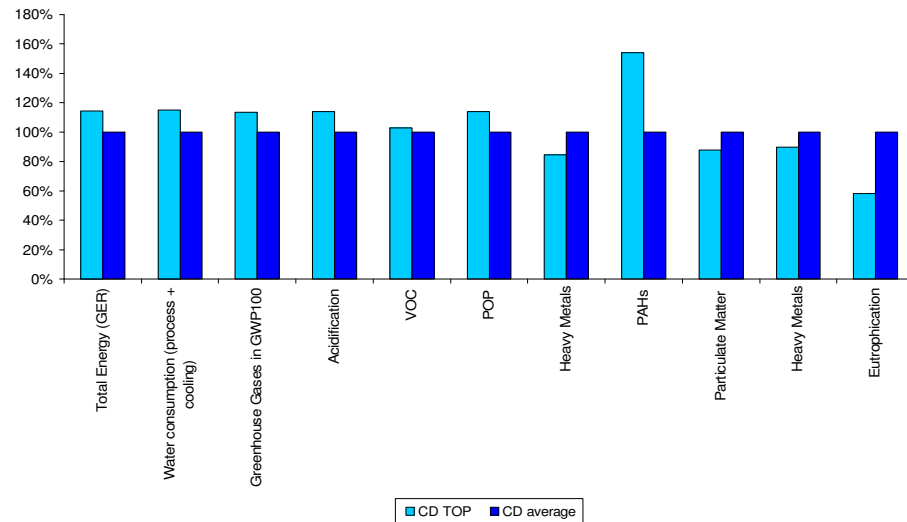

Figure 148: Comparison between the Base Case condenser dryer and the top condenser dryer

V.3.3 Preliminary conclusions

The environmental impact assessment of each Base Case using the EuP EcoReport leads to the following conclusions:

- Relating to energy, the most impacting phase is the use phase. Moreover, the impact of the base case choice is highlighted. Indeed, in real life conditions, the energy consumption is always higher.
- Relating to the impacts on air and water, the impact is shared between the production and the use phase.
- Steel is the main contributor to air and water pollution during the manufacturing phase. This impact can be mainly allocated to the housing. Indeed, it is the biggest part made of steel.
- The use of aluminium in some models (especially in compact and front dryers) is responsible for PAH emissions (substances detrimental for human health).

These conclusions allow validating the choice of average products as Base Cases for each type of product. Indeed, the most impacting phase is the use phase and the BOM has an influence only on the production phase. Moreover, the main contributors to the production phase are steel, PP and ABS, and these two materials are present in high quantity in all the models studied.

In the light of the present conclusions, the analysis of the improvement potential in task 6 and 7 will mainly focus on technologies that reduce the power consumption and improve energy efficiency.

To conclude, we compare Class C air vented dryer and Class C air condenser dryer in absolute values. Under standard conditions, the air vented condenser dryer has a lower impact on the environment, mainly due to its lower energy consumption. But considering the fact that the drying performance of an air vented condenser dryer are largely depending on the atmospheric conditions a sensitivity analysis has to be performed relating to the dryer location and the ambient conditions.

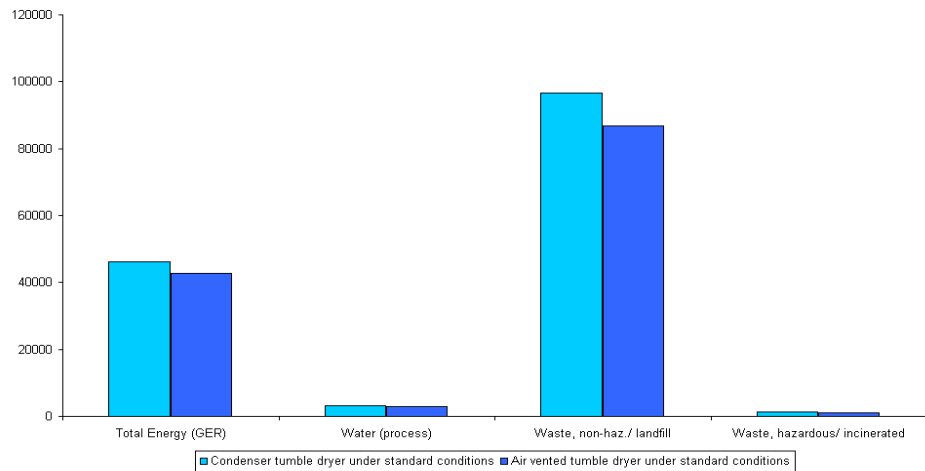

Figure 149: Comparison between the Base Case condenser dryer and the Base case Air Vented Dryer (Consumption & Wastes)

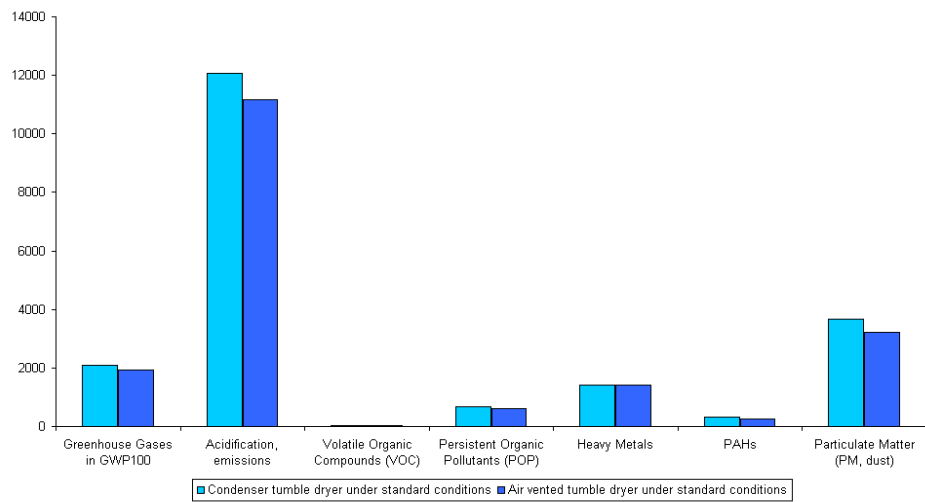

Figure 150: Comparison between the Base Case condenser dryer and the Base case Air Vented Dryer (Emission to air)

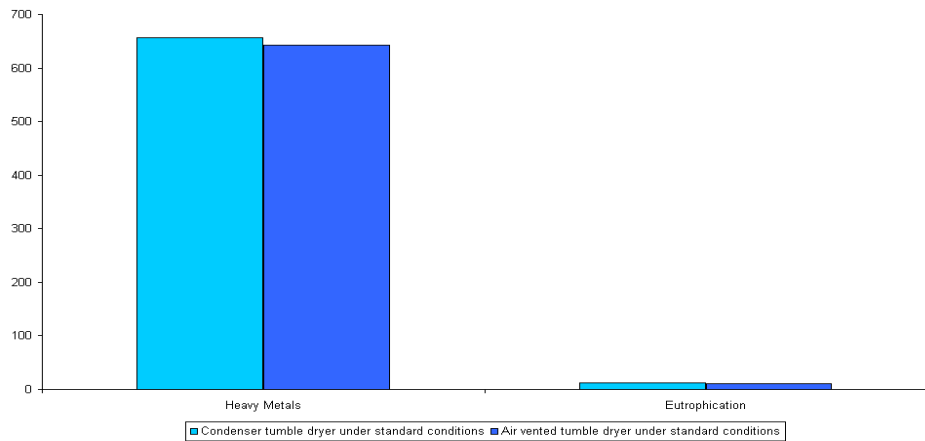

Figure 151: Comparison between the Base Case condenser dryer and the Base case Air Vented Dryer (Emission to water)

V.4 Base Case Life Cycle Costs (Subtask 5.4)

The Life Cycle Costs (LCC) for the chosen Base Cases are estimated through economic assumptions, including the street prices for several models of tumble dryers. The LCC of the Base Case, under standard and real life conditions, is the starting point for the optimisation of the technology options (BAT/BNAT) in Task 6. As in task 4, sensitivity analyses will be carried out on the following types of tumble dryers: compact air vented tumble dryers and top condenser tumble dryers.

V.4.1 LCC for the Base Case air vented tumble dryer

Key technical and financial assumptions

The following parameters and data have been taken into account in the calculation:

- Product life cycle: 13 years
- Energy efficiency: C Class
- Load capacity: 6 kg
- Cycles per year:
 - Under standard conditions: 88
 - Under real life conditions: 155
- Prices:
 - Average laundry dryer sales 380 Euros⁹⁰
 - Electricity: 0.17 Euros / kWh⁹¹
 - Maintenance & repairs 5.5 Euros / year
 - Disposal & recycling 41 Euros

Note:

- Regarding the disposal and recycling price, the same assumption as in the Lot 14 study (for washing machines) was made: without reliable data available at the EU Member States level on end of life costs of used appliances, the considered data come from task 2 (economical analysis) where recycling and systems costs from 1999-2001 were given for six European countries that had experience in recycling of electrical and electronic equipment before the WEEE directive came into force. The costs range from 1,90 euros per kg for Belgium to 0,92 euros per kg for Sweden, with a European average of 1,21 Euros per kg.
- According to these data, an air vented tumble dryer having an average weight of 34 kg (packaging excluded), the recycling cost of the used dryer is around 41 euros.
- Annual sales (2005):
 - The data from task 2 are the number of tumble dryers sold in Europe (Western and Eastern) in 2005: a total of 3 706 752 units.

⁹⁰ Average data coming from manufacturers' data. This data confirms the results of the consumer survey where around 40% of the price of laundry dryers are between 200 and 399 Euros.

⁹¹ This data is the same as in Lot 14. It is the average forecast price for 2015 in real terms. The current price of electricity is 0.14 euros/kWh as shown in Task 2.

Table 84: Sales of C Class tumble dryers, 6kg, by type of technology and type of loading, in Western and Eastern Europe (2005)

C class tumble dryers	
3 325 417	
C Class, 6 kg (51,8%)	
1 722 566	
Air vented tumble dryer C class, 6 kg (45 %)	Condenser tumble dryer C class, 6 kg (55%)
775 155	947 411

These figures result from Table 20 and the following assumptions:

- Market ratio of the 6 kg load capacity tumble dryers: 51,8% (Table 18)
- Market ratio of air vented / condenser tumble dryers: 45% / 55% (Table 14).

For air vented dryers fulfilling the specifications for the Base Case (air vented tumble dryers, class C, 6kg capacity), the annual sales in 2005 represent **775 155 units**.

Total EU stock

- The total EU Stock (EU 15, 2005)⁹² for tumble dryers is 53,65 million units.
- The total EU stock was calculated with data from 1990

Table 85: EU Stock (EU 15, 2005), of C class, 6 kg load capacity, tumble dryers⁹³

Air vented tumble dryer C class, 6 kg	Condenser tumble dryer C class, 6 kg
27.479 mln units	26.435 mln units

* See the calculation methods in Annexe

The following inputs for the EcoReport were entered for the Base Case:

⁹² The stock model was calculated considering a constant perimeter with 15 EU countries. Nevertheless, the stock for new coming countries, especially in Eastern Europe, can be considered as relatively low.

⁹³ The same ratios considered for 2005 sales are used for the stock evaluations.

Table 86: EcoReport inputs for the calculation of the LCC of the Base Case air vented tumble dryer (2005)

INPUTS FOR EU-Totals & economic Life Cycle Costs			unit
nr	Description		
A	Product Life	13	years
B	Annual sales	0,775	mln. Units/year
C	EU Stock	27,479	mln. Units
D	Product price	380	Euro/unit
E	Installation/acquisition costs (if any)		Euro/ unit
F	Fuel rate (gas, oil, wood)		Euro/GJ
G	Electricity rate	0,17	Euro/kWh
H	Water rate		Euro/m3
I	Aux. 1: None		Euro/kg
J	Aux. 2 :None		Euro/kg
K	Aux. 3: None		Euro/kg
L	Repair & maintenance costs	71,5	Euro/ unit
M	Discount rate (interest minus inflation)	5,0%	%
N	Present Worth Factor (PWF) (calculated automatically)	9,39	(years)
O	Overall Improvement Ratio STOCK vs. NEW, Use Phase	1,00	

Using these Figure s for the Base Case air vented tumble dryer under both standard and real life conditions, the LCC are calculated in the following paragraph.

Analysis of the results for the Base Case air vented tumble dryer

The following table displays the results of the EcoReport for the life cycle costs (LCC) of the Base Case air vented tumble dryer.

Table 87 shows the results under standard conditions with the Base Case air vented dryer.

Table 87: EcoReport results for the LCC of the air vented tumble dryer Base Case under standard conditions (STBC Air vented)

Air Vented Tumble Dryer (Front, 6kg) Standard Item	LCC new product	total annual consumer expenditure in EU25
D Product price	380 €	295 mln.€
E Installation/ acquisition costs (if any)	0 €	0 mln.€
F Fuel (gas, oil, wood)	0 €	0 mln.€
F Electricity	474 €	1386 mln.€
G Water	0 €	0 mln.€
H Aux. 1: None	0 €	0 mln.€
I Aux. 2 :None	0 €	0 mln.€
J Aux. 3: None	0 €	0 mln.€
K Repair & maintenance costs	52 €	151 mln.€
Total	906 €	1832 mln.€

The electricity costs represent a major share of the LCC (52.3%) followed by the product purchase costs (41.9%).

Table 88 shows the results under real life conditions with the Base Case air vented dryer.

Table 88: EcoReport results for the LCC for the Base Case air vented tumble dryer under real life conditions (RLBC Air vented)

Air Vented Tumble Dryer (Front, 6kg) Real Life Item	LCC new product	total annual consumer expenditure in EU25
D Product price	380 €	295 mln.€
E Installation/ acquisition costs (if any)	0 €	0 mln.€
F Fuel (gas, oil, wood)	0 €	0 mln.€
F Electricity	499 €	1460 mln.€
G Water	0 €	0 mln.€
H Aux. 1: None	0 €	0 mln.€
I Aux. 2 :None	0 €	0 mln.€
J Aux. 3: None	0 €	0 mln.€
K Repair & maintenance costs	52 €	151 mln.€
Total	931 €	1906 mln.€

Under real life conditions (less loading), there is a slight increase of the electricity consumption. Regarding the LCC costs, the electricity costs represent a major share of the LCC (53.5%) followed by the product purchase costs (40.8%).

Sensitivity analysis for compact air vented tumble dryers

The following parameters and data have been taken into account:

- Product life cycle: 13 years
- Energy efficiency = D Class (C not available)
- Load capacity: 3 kg
- Cycles per year:
 - Under standard conditions: 175
 - Prices:
 - Average laundry dryer sales 244 Euros⁹⁴
 - Electricity: 0.17 Euros / kWh⁹⁵
 - Maintenance & repairs 5.5 Euros / year
 - Disposal & recycling 28 Euros⁹⁶

⁹⁴ Average data coming from manufacturers' data.

⁹⁵ This data is the same as in Lot 14. It is the average forecast price for 2015 in real terms. The current price of electricity is 0.14 euros/kWh as shown in Task 2.

⁹⁶ A compact air vented tumble dryer having an average weight of 23kg (see task 4), it comes that the recycling cost of the used dryer is around 28 Euros.

Table 89: EcoReport results LCC for the compact air vented tumble dryer, D Class, Front, under standard conditions

Compact air vented tumble dryer (Front, 3kg) Standard <i>Item</i>	LCC new product
D Product price	244 €
E Installation/ acquisition costs (if any)	0 €
F Fuel (gas, oil, wood)	0 €
F Electricity	505 €
G Water	0 €
H Aux. 1: None	0 €
I Aux. 2 :None	0 €
J Aux. 3: None	0 €
K Repair & maintenance costs	52 €
Total	800 €

The electricity cost represents a major share of the LCC (63%) followed by the product purchase costs (30,5%).

V.4.2 LCC for the Base Case condenser tumble dryer

Key technical and financial assumptions

The following parameters and data have been taken into account in the calculation:

- Product life cycle: 13 years
- Energy efficiency: C Class
- Load capacity: 6 kg
- Cycles per year:
 - Under standard conditions: 88
 - Under real life conditions: 155
- Prices:
 - Average laundry dryer sales 547 Euros⁹⁷
 - Electricity: 0.17 Euros / kWh⁹⁸
 - Maintenance & repairs 5.5 Euros / year
 - Disposal & recycling 51 Euros⁹⁹
- Annual sales (2005):
 - Data from task 2 are the sales of tumble dryers in Europe (Western and Eastern) in 2005, a total of 3 706 752 units, including 862 144 units of condenser tumble dryers, C class, 6 kg, front loading
 - EU Stock (EU 15, 2005), a total of 53,65 millions units, including 12,48 millions units of condenser tumble dryers, C class, 6 kg, front loading

⁹⁷ Average data coming from manufacturers' data.

⁹⁸ This data is the same as in Lot 14. It is the average forecast price for 2015 in real terms. The current price of electricity is 0.14 euros/kWh as shown in Task 2.

⁹⁹ A condenser tumble dryer having an average weight of 42 kg, it comes that the recycling cost of the used dryer is around 51 Euros.

The following inputs of the EcoReport were entered for the Base Case:

Table 90: EcoReport inputs for the calculation of the LCC of the Base Case condenser tumble dryer (2005)

nr	INPUTS FOR EU-Totals & economic Life Cycle Costs Description		unit
A	Product Life	13	years
B	Annual sales	0,947	mln. Units/year
C	EU Stock	26,435	mln. Units
D	Product price	547	Euro/unit
E	Installation/acquisition costs (if any)		Euro/ unit
F	Fuel rate (gas, oil, wood)		Euro/GJ
G	Electricity rate	0,17	Euro/kWh
H	Water rate		Euro/m3
I	Aux. 1: None		Euro/kg
J	Aux. 2 :None		Euro/kg
K	Aux. 3: None		Euro/kg
L	Repair & maintenance costs	71,5	Euro/ unit
M	Discount rate (interest minus inflation)	5,0%	%
N	Present Worth Factor (PWF) (calculated automatically)	9,39	(years)
O	Overall Improvement Ratio STOCK vs. NEW, Use Phase	1,00	

Analysis of the results for the Base Case condenser tumble dryer

Table 91: EcoReport results for the LCC of the Base Case condenser tumble dryer under standard conditions

Condenser tumble dryer (Front, 6 kg) Standard Item	LCC new product	total annual consumer expenditure in EU25
D Product price	547 €	518 mln.€
E Installation/ acquisition costs (if any)	0 €	0 mln.€
F Fuel (gas, oil, wood)	0 €	0 mln.€
F Electricity	508 €	1428 mln.€
G Water	0 €	0 mln.€
H Aux. 1: None	0 €	0 mln.€
I Aux. 2 :None	0 €	0 mln.€
J Aux. 3: None	0 €	0 mln.€
K Repair & maintenance costs	52 €	145 mln.€
Total	1106 €	2092 mln.€

The product purchase cost represents a major share of the LCC (49.5%) followed by the electricity costs (46%).

Table 92: EcoReport results LCC for the condenser tumble dryer, C Class, 6 kg, under real life conditions

Real Life <i>Item</i>	LCC new product	total annual consumer expenditure in EU25
D Product price	547 €	518 mln.€
E Installation/ acquisition costs (if any)	0 €	0 mln.€
F Fuel (gas, oil, wood)	0 €	0 mln.€
F Electricity	534 €	1502 mln.€
G Water	0 €	0 mln.€
H Aux. 1: None	0 €	0 mln.€
I Aux. 2 :None	0 €	0 mln.€
J Aux. 3: None	0 €	0 mln.€
K Repair & maintenance costs	52 €	145 mln.€
Total	1132 €	2166 mln.€

Under real life, the product purchase cost still represents the major share of the LCC (48.3%) followed by the electricity costs (47.1%).

Sensitivity analysis for top condenser tumble dryers

The following parameters and data have been taken into account in the calculation for this specific type of condenser tumble dryer.

- Product life cycle: 13 years
- Energy efficiency: C Class
- Load capacity: 5 kg
- Cycles per year:
- Under standard conditions: 105
- Prices:
 - Average laundry dryer sales 555 Euros¹⁰⁰
 - Electricity: 0.17 Euros / kWh¹⁰¹
 - Maintenance & repairs 5.5 Euros / year
 - Disposal & recycling 45 Euros¹⁰²

¹⁰⁰ Average data coming from manufacturers' data.

¹⁰¹ This data is the same as in Lot 14. It is the average forecast price for 2015 in real terms. The current price of electricity is 0.14 euros/kWh as shown in Task 2.

¹⁰² A top condenser tumble dryer having an average weight of 37 kg (see task 4), it comes that the recycling cost of the used dryer is around 45 Euros.

Table 93: EcoReport results for the LCC for a condenser tumble dryer, C Class, Top, 5 kg, under standard conditions

Products <i>Item</i>	LCC new product
D Product price	555 €
E Installation/ acquisition costs (if any)	0 €
F Fuel (gas, oil, wood)	0 €
F Electricity	587 €
G Water	0 €
H Aux. 1: None	0 €
I Aux. 2: None	0 €
J Aux. 3: None	0 €
K Repair & maintenance costs	52 €
Total	1194 €

The electricity cost represents a major share of the LCC (49%) followed by the product purchase costs (46%).

V.4.3 Preliminary conclusions

Regarding the LCC results for the two Base Cases and the sensitivity analyses (compact, top), it can be concluded that the electricity cost generally represents the highest investment. Indeed, the purchase cost is the highest only for air condenser tumble dryers, and represents an average of 50% of the LCC under standard and real life conditions.

Concerning air vented compact tumble dryers, the average ratio concerning electricity cost is 63%, it is higher than for other types of dryers but considering that only data for D class compact dryers are available, this is coherent.

V.5 EU Totals (Subtask 5.5)

V.5.1 EU total environmental assessment of air vented tumble dryers

Table 94 shows the environmental impact of all air vented dryers sold in 2005.

Table 95 shows the environmental impacts of the EU 25 total stock of dryers in 2005 (i.e. all products sold plus installed base). They are calculated on the basis of the standard base case.

The air vented dryer stock is responsible for the emission of 4 mtCO₂ eq. and for the consumption of 8.2 TWh of electricity.

Table 94: EcoReport output for air vented tumble dryers sold in the EU 25 in 2005

Life Cycle phases -->	Resources Use and Emissions	PRODUCTION			DISTRIBU- TION	USE	END-OF-LIFE*		TOTAL	
		Material	Manuf.	Total			Disposal	Recycl.		Total
Materials		unit								
1	Bulk Plastics	kt			4		0	3	4	0
2	TecPlastics	kt			2		0	2	2	0
3	Ferro	kt			17		1	17	17	0
4	Non-ferro	kt			1		0	1	1	0
5	Coating	kt			0		0	0	0	0
6	Electronics	kt			1		1	0	1	0
7	Misc.	kt			1		0	1	1	0
	Total weight	kt			27			24	27	0
Other Resources & Waste		<i>see note!</i>								
8	Total Energy (GER)	PJ	1	0	1	0	32	0	0	33
9	of which, electricity (in primary PJ)	PJ	0	0	0	0	31	0	0	32
10	Water (process)	mln. m3	0	0	0	0	2	0	0	2
11	Water (cooling)	mln. m3	0	0	1	0	84	0	0	84
12	Waste, non-haz./landfill	kt	28	1	29	0	37	2	0	67
13	Waste, hazardous/ incinerated	kt	0	0	0	0	1	0	0	1
Emissions (Air)										
14	Greenhouse Gases in GWP100	mt CO2 eq.	0	0	0	0	1	0	0	1
15	Ozone Depletion, emissions	t R11 eq.	negligible							
16	Acidification, emissions	kt SO2 eq.	0	0	0	0	8	0	0	9
17	Volatile Organic Compounds (VOC)	kt	0	0	0	0	0	0	0	0
18	Persistent Organic Pollutants (POP)	g i-Teq	0	0	0	0	0	0	0	0
19	Heavy Metals	ton Ni eq.	0	0	0	0	1	0	0	1
	PAHs	ton Ni eq.	0	0	0	0	0	0	0	0
20	Particulate Matter (PM, dust)	kt	0	0	0	1	1	0	0	2
Emissions (Water)										
21	Heavy Metals	ton Hg/20	0	0	0	0	0	0	0	0
22	Eutrophication	kt PO4	0	0	0	0	0	0	0	0
23	Persistent Organic Pollutants (POP)	g i-Teq	negligible							

Table 95: EcoReport output for the EU25 total stock of air vented tumble dryers in 2005

Life Cycle phases -->	PRODUCTION			DISTRIBUITION	USE	END-OF-LIFE*			TOTAL	
	Resources Use and Emissions	Material	Manuf.			Total	Disposal	Recycl.		Total
Materials		unit								
1 Bulk Plastics	kt			4			0	3	4	0
2 TecPlastics	kt			2			0	2	2	0
3 Ferro	kt			17			1	17	17	0
4 Non-ferro	kt			1			0	1	1	0
5 Coating	kt			0			0	0	0	0
6 Electronics	kt			1			1	0	1	0
7 Misc.	kt			1			0	1	1	0
Total weight	kt			27			2	24	27	0
Other Resources & Waste		<i>see note!</i>								
8 Total Energy (GER)	PJ			1	0	86	0	0	0	88
9 of which, electricity (in primary PJ)	PJ			0	0	86	0	0	0	86
10 Water (process)	mln. m3			0	0	6	0	0	0	6
11 Water (cooling)	mln. m3			0	0	228	0	0	0	229
12 Waste, non-haz./ landfill	kt	28	1	29	0	100	2	0	2	131
13 Waste, hazardous/ incinerated	kt			0	0	2	0	0	0	2
Emissions (Air)										
14 Greenhouse Gases in GWP100	mt CO2 eq.			0	0	4	0	0	0	4
15 Ozone Depletion, emissions	t R-11 eq.					negligible				
16 Acidification, emissions	kt SO2 eq.			0	0	22	0	0	0	23
17 Volatile Organic Compounds (VOC)	kt			0	0	0	0	0	0	0
18 Persistent Organic Pollutants (POP)	gi-Teq			0	0	1	0	0	0	1
19 Heavy Metals	ton Ni eq.			0	0	2	0	0	0	2
PAHs	ton Ni eq.			0	0	0	0	0	0	0
20 Particulate Matter (PM, dust)	kt			0	0	1	3	0	0	5
Emissions (Water)										
21 Heavy Metals	ton Hg/20			0	0	1	0	0	0	1
22 Eutrophication	kt PO4			0	0	0	0	0	0	0
23 Persistent Organic Pollutants (POP)	gi-Teq					negligible				

Table 96: Summary of the environmental impacts of the EU 25 total stock of air vented tumble dryers in 2005

Table . Summary Environmental Impacts EU-Stock 2005, Air Vented Tumble Dryer (Front, 6kg) Standard

main life cycle indicators	value unit
Total Energy (GER)	88 PJ
<i>of which, electricity</i>	8,2 TWh
Water (process)*	6 mln.m3
Waste, non-haz./ landfill*	131 kton
Waste, hazardous/ incinerated*	2 kton

Emissions (Air)

Greenhouse Gases in GWP100	4 mt CO2eq.
Acidifying agents (AP)	23 kt SO2eq.
Volatile Org. Compounds (VOC)	0 kt
Persistent Org. Pollutants (POP)	1 gi-Teq.
Heavy Metals (HM)	2 ton Ni eq.
PAHs	0 ton Ni eq.
Particulate Matter (PM, dust)	5 kt

Emissions (Water)

Heavy Metals (HM)	1 ton Hg/20
Eutrophication (EP)	0 kt PO4

* = caution: low accuracy for production phase

V.5.2 EU total environmental assessment of condenser tumble dryers

The EU 25 stock of air condenser dryers is responsible for the emission of 4mtCO₂ eq and for the consumption of 8.5 TWh of electricity in 2005. They are calculated on the basis of the standard base case.

When adding the electricity consumption for both air vented and condenser dryers sold in 2005 (1.7 mln units) the total electricity consumption amounts to 7.05 TWh.

To put this into perspective, it can be noted that in the EuP preparatory on washing machines, it was highlighted that washing machine sold in 2005 (11, 6 mln units) were responsible for the consumption of 38.2 TWh: this represents only 5.4 times more than that of dryers sales.

Table 97: EcoReport output for models sold in 2005 (for the standard base case)

Life Cycle phases -->	Resources Use and Emissions	PRODUCTION			DISTRIBUION	USE	END-OF-LIFE*			TOTAL	
		Material	Manuf.	Total			Disposal	Recycl.	Total		
Materials		unit									
1	Bulk Plastics	kt			12			0	12	12	0
2	Tec-Plastics	kt			1			0	1	1	0
3	Ferro	kt			22			1	21	22	0
4	Non-ferro	kt			1			0	1	1	0
5	Coating	kt			0			0	0	0	0
6	Electronics	kt			2			2	0	2	0
7	Misc.	kt			2			0	2	2	0
	Total weight	kt			40			4	36	40	0
Other Resources & Waste		see note!									
8	Total Energy (GER)	PJ	2	1	2	1	41	0	1	0	44
9	of which, electricity (in primary PJ)	PJ	0	0	1	0	41	0	0	0	42
10	Water (process)	mln. m3	0	0	0	0	3	0	0	0	3
11	Water (cooling)	mln. m3			1	0	110	0	0	0	110
12	Waste, non-haz./ landfill	kt	39	2	41	0	48	2	0	2	91
13	Waste, hazardous/ incinerated	kt	0	0	0	0	1	0	0	0	1
Emissions (Air)											
14	Greenhouse Gases in GWP100	mt CO2 eq.	0	0	0	0	2	0	0	0	2
15	Ozone Depletion, emissions	t R-11 eq.					negligible				
16	Acidification, emissions	kt SO2 eq.	1	0	1	0	11	0	0	0	11
17	Volatile Organic Compounds (VOC)	kt	0	0	0	0	0	0	0	0	0
18	Persistent Organic Pollutants (POP)	gi-Teq	0	0	0	0	0	0	0	0	1
19	Heavy Metals	ton Ni eq.	0	0	0	0	1	0	0	0	1
	PAHs	ton Ni eq.	0	0	0	0	0	0	0	0	0
20	Particulate Matter (PM, dust)	kt	0	0	0	1	2	1	0	1	3
Emissions (Water)											
21	Heavy Metals	ton Hg/20	0	0	0	0	0	0	0	0	1
22	Eutrophication	kt PO4	0	0	0	0	0	0	0	0	0
23	Persistent Organic Pollutants (POP)	gi-Teq					negligible				

Table 98: EcoReport output for the EU stock of condenser dryers (2005) (for the standard base case)

Life Cycle phases -->	PRODUCTION			DISTRIBU- TION	USE	END-OF-LIFE*			TOTAL	
	Resources Use and Emissions	Material	Manuf.			Total	Disposal	Recycl.		Total
Materials										
		unit								
1 Bulk Plastics	kt			12			0	12	12	0
2 TecPlastics	kt			1			0	1	1	0
3 Ferro	kt			22			1	21	22	0
4 Non-ferro	kt			1			0	1	1	0
5 Coating	kt			0			0	0	0	0
6 Electronics	kt			2			2	0	2	0
7 Misc.	kt			2			0	2	2	0
Total weight	kt			40			4	36	40	0
Other Resources & Waste										
		see note!								
8 Total Energy (GER)	PJ	2	1	2	1	89	0	1	0	91
9 of which, electricity (in primary PJ)	PJ	0	0	1	0	88	0	0	0	89
10 Water (process)	mln.m3	0	0	0	0	6	0	0	0	6
11 Water (cooling)	mln.m3	1	0	1	0	235	0	0	0	236
12 Waste, non-haz./ landfill	kt	39	2	41	0	103	2	0	2	147
13 Waste, hazardous/ incinerated	kt	0	0	0	0	2	0	0	0	2
Emissions (Air)										
14 Greenhouse Gases in GWP100	mt CO2 eq.	0	0	0	0	4	0	0	0	4
15 Ozone Depletion, emissions	tR-11 eq.					negligible				
16 Acidification, emissions	kt SO2 eq.	1	0	1	0	23	0	0	0	24
17 Volatile Organic Compounds (VOC)	kt	0	0	0	0	0	0	0	0	0
18 Persistent Organic Pollutants (POP)	gi-Teq	0	0	0	0	1	0	0	0	1
19 Heavy Metals	ton Ni eq.	0	0	0	0	2	0	0	0	2
20 PAHs	ton Ni eq.	0	0	0	0	0	0	0	0	0
20 Particulate Matter (PM, dust)	kt	0	0	0	1	3	1	0	1	5
Emissions (Water)										
21 Heavy Metals	ton Hg/20	0	0	0	0	1	0	0	0	1
22 Eutrophication	kt PO4	0	0	0	0	0	0	0	0	0
23 Persistent Organic Pollutants (POP)	gi-Teq					negligible				

Table 99: EcoReport output for the EU stock of condenser tumble dryers (2005)

Table . Summary Environmental Impacts EU-Stock 2005, Condenser tumble dryer (Front, 6 kg) Standard

main life cycle indicators	value unit
Total Energy (GER)	91 PJ
<i>of which, electricity</i>	8,5 TWh
Water (process)*	6 mln.m3
Waste, non-haz./ landfill*	147 kton
Waste, hazardous/ incinerated*	2 kton
Emissions (Air)	
Greenhouse Gases in GWP100	4 mt CO2eq.
Acidifying agents (AP)	24 kt SO2eq.
Volatile Org. Compounds (VOC)	0 kt
Persistent Org. Pollutants (POP)	1 gi-Teq.
Heavy Metals (HM)	2 ton Ni eq.
PAHs	0 ton Ni eq.
Particulate Matter (PM, dust)	5 kt
Emissions (Water)	
Heavy Metals (HM)	1 ton Hg/20
Eutrophication (EP)	0 kt PO4

*= caution: low accuracy for production phase

Annexes to Task 5

N References

- VHK Van Holsteijn en Kemma BV (2005), MEEuP methodology report, Final Report

O Summary of comments from stakeholders

Submission	Comment	Response
31/10/2008 Jürg Nipkow Arena Energy	The HP dryer is not included in base cases. This may be accepted from the point of view of its actual spreading in the field. We suggest that it should at least be mentioned in preliminary conclusions (5.3). The relations of purchase and energy costs of heat pump dryers differs from those of vented and condenser dryers.	Indeed, from the point of view of their market share, heat pump dryers do not appear as Base Cases. Moreover, it was agreed during the stakeholder meeting that they would be considered as BAT in this study. The assessment of their life cycle environmental impact and costs will be performed in task 7. (This is also true for gas dryers).
31/10/2008 Natuur en Milieu	Chapter 2, p.14 As stated earlier in the report the cleanliness of the filter is of utmost importance. This means in practice that a (partially) clogged filter will have a negative influence. This is not taken into account yet in the RLBC.	No data about filter cleanliness/Figure s relating to energy losses due to clogging are available. Moreover, there is no way of knowing if (partial) clogging actually characterizes real life use. Thus, we have not taken this aspect into account in our Real life base case. However, in order to be as transparent as possible concerning our approach, a comment was added in the definition of the real life base case.
31/10/2008 Natuur en Milieu	Chapter 2, p.43 The conclusion that in real life conditions the energy consumption will be higher will not surprise anybody. More important how much higher.	The value in percentage was added. 5% of additional consumption for an air vented dryer under real life conditions; 4% of additional consumption for a condenser dryer under real life conditions
31/10/2008 Natuur en Milieu	Chapter 3 Do laundry dryers contain flame-retardant and if so which. (this is also important for sorting/recycling)	We don't have information on flame-retardant in laundry dryers. But the ecoreport tool does not have such a level of accuracy. As for manufacturing/ sorting/recycling, facilities should be equipped to fulfil the legal requirements of the RoHS and WEEE directives.
31/10/2008 Natuur en Milieu	Chapter 5, p.42 The assumption that disposal and recycling will cost 41 euro's is questionable as it seems to be based on average Figure s for electronic equipment. Especially basic air vented and air condensor tumble dryers will costs less as the BOM shows that the materials are mainly metals (large parts) and plastic. For heat pump condenser dryers this may be different due to the presence of refrigerant.	Ok. However, these are the most reliable data which are available. Should we find more detailed data, they will be taken into account.
31/10/2008 Natuur en Milieu	Chapter 5, p.45 As prices of electricity within the EU are varying significantly (table 26, task 2: 7- 21 euro's/100kwh) average LCC calculations are for these much electricity consuming equipment of very limited value. It is better to present ranges than use average Figure s.	The same value as for washing machines was used, in order to obtain results coherent with those of lot 14. Moreover, a sensitivity analysis on electricity prices will be performed in task 8. This is why presenting ranges is not the approach adopted in this study.

Submission	Comment	Response
<p>31/10/2008 Danish Energy Agency</p>	<p>Page 12 The annual energy consumption of the standard base case should be calculated as the energy consumption per drying cycle multiplied by the average annual number of drying cycles (155 cycles). The intention of the real life base case is to illustrate the difference between energy consumption and other environmental impacts in standard condition compared to real life. However this comparison is totally mixed up because of the chosen definition of the functional unit and the resulting reduction of the annual number of drying cycles in the standard base case. We recommend the functional unit to be defined as: Drying the laundry of one cycle.</p>	<p>From the life cycle analysis perspective, it is the environmental performance of products providing the same service which should be compared. Now, roughly, it was agreed for this study that the service provided by laundry dryers is to dry a certain amount of laundry. In order to have comparable situations in both base cases, it is thus necessary to consider the same quantity of linen dried. In this study, the chosen functional unit is the annual amount of linen dried by a European household, expressed simply as "drying the linen of one family during one year". Based on our consumer survey and exchanges with experts, an average European household uses the dryer for about 155 cycles a year, loaded with 3.4 kg per cycle, thus corresponding to drying $155 * 3.4 = 527$ kg of linen every year. Under standard conditions, the loading is per cycle is 6 kg. In order to dry the same quantity of linen, $527/6 = 88$ cycles should be considered.</p>
<p>31/10/2008 Danish Energy Agency</p>	<p>Page 19 and 20 (table 9 and 10) The yearly energy consumption of the standard base case is lower than in the real life base case. This should however not be the case. Page 23 (table 15 and 16) The same comments as above (to page 19 and 20) Page 41 It is concluded that the energy consumption in real life condition is always higher than in the standard base case. If you look at one drying cycle there is no doubt that the energy consumption in the standard condition is higher than in the real life condition. Things get mixed up because of the method used.</p>	<p>As previously said, in order to compare the different scenarii, it is necessary to consider the same quantity of linen to be dried. In real life conditions, tumble dryers are usually less loaded than in standard conditions. Since using a dryer only partially loaded leads to a higher unitary energy consumption (i.e. per kg of load), it is coherent that the total annual real energy consumption, to dry the same amount of linen, is higher in real life conditions than in standard conditions. The unitary energy consumption was added in the definition of the base cases. As explained in the report, the energy consumption is not linearly dependent of the load. In any case, there is a certain fixed amount of energy needed to heat up the appliance's structure and its components.</p>
<p>31/10/2008 Danish Energy Agency</p>	<p>Page 53 and 55 Are the values in table 33 and table 36 corresponding to the standard base case situation or a real life base case situation (number of cycles and load)?</p>	<p>The values are given for the standard base case. The precision was added in the titles of the tables.</p>

VI Task 6: Technical analysis of Best Available Technology (BAT)

VI.1 State of the art already on the market (product level)

A main objective of the EuP preparatory study is to identify how to improve the product in terms of environmental impact without entailing excessive costs (to the consumer, to the industry, etc.). The base case defined in task 5 will serve as the reference for the improvement. Now, the purpose of task 6 consists in identifying a list of design options that could contribute to achieving a better environmental performance and providing an estimate their costs to the different stakeholders in the short, medium and long term from literature and/or expert sources. The evaluation of the environmental impacts and life cycle costs (LCC) of these options and their combinations will be performed in task 7, and a sensitivity analysis on major parameters will be carried out in task 8.

The purpose of task 6 is to identify design options and provide first elements on their costs

Their associated environmental impacts and life cycle costs will be studied in next tasks

According to the MEEUP methodology report (VHK, 2005), design options will be identified based on the study of Best Available Technologies (BAT) on the market now or within 2-3 years, on the assessment of state of the art in applied research (at product and component level, both within and outside the European Union) but also based on a design engineering approach. The technical analysis carried out in Task 4 will serve as an input for this purpose. Best Non Available Technologies (BNAT), which are still in development and not introduced on the market at this time and which represent longer term options, will be described and assessed based on a literature survey and exchanges with expert stakeholders.

The environmental benefits and costs of the options identified will be evaluated, individually and/or in combinations.

VI.1.1 Information collection

The information used in this report was gathered from a number of different sources.

Many important inputs were provided by industry professionals from major European and international manufacturers. These sources permit a detailed insight into the current state of the art in dryer technology. They also contributed to the assessment of not yet available technology due to their own research and development efforts.

Other sources were also included in the data acquisition process in order to complete the information collected with industrials.

The sources consulted include exchanges with industrials, governmental studies and research papers.

Governmental studies, available from national and EU bodies, were also consulted during the study. These studies characteristically take into account regional and geographical factors that influence the market and the user behaviour and hence provide valuable information aside from solely technical considerations.

For the technical aspects, research papers are an important source. They particularly allow to assess new technologies because the development of technology is their first and foremost aim, while commercial aspects play a secondary role.

It was an important task in the preparation of this document to check the different sources against each others and balance the different points of view to ensure the quality of the data base

VI.1.2 Best available technologies on the market (product level)

As detailed in the previous tasks of this study, there are two main types of laundry dryers: Vented dryers and condenser dryers. Vented dryers intake compartment air, possibly heat it, use it to dry the clothes inside the drum, and blow out the humid air

through an exhaust pipe (to the atmosphere instead of back into the room). Condenser dryers, with circulating airflow, process the amount of air available inside the drum only. They do not have an air exhaust pipe connection: the water which is removed from the clothes will either be collected in a reservoir or pumped into the drain as with washing machines.

In the following, the functional principle of the different dryer technologies will be explained. We will set aside aspects that do not directly influence the thermodynamic working principle of the dryer (e.g. the material of the casing, the type of electric motor which do not fundamentally differ for dryers on the market and will be discussed in more detail in section VI.2) and thus only discuss the different heating elements and humidity removing facilities in use.

Vented tumble dryers

In air vented tumble dryers, heat is generated using electric energy and resistors. Compartment air is heated by a heating element and forced through the laundry, dehumidifying it. The humid air is blown out to the atmosphere, so there is no necessity for a condensate reservoir or a drain. The best performing products for this technology only achieve a C energy class.

The energy efficiency of traditional air vented dryers could be improved by recovering some heat from the air that is blown out, especially at the end of the cycle, when relative humidity decreases at the drum outlet. Setting up such a system would require the use of a “high heat exchanger”, because the outlet temperature of a vented dryer is very low over the main drying phase, depending on the drying efficiency of the product itself. Either a air-air heat exchanger or a mixing valve which would by-pass and recycle part of the blown out flow may be used. It would almost amount to having the design of a condenser dryer in an air vented dryer. As the exhaust air would be saturated (close to 100% relative humidity), this has to be considered regarding the exhaust pipe installation. Moreover, too much cooling down of the exhaust air would cause the water to condense inside the dryer, which is unacceptable. If there was condensation of the exhaust air, the water (condensate) would need to be handled (by a pump, a container, etc.). In terms of costs, this solution would bring the costs of this kind of products very close to those of a condenser dryer.

A literature source suggests that this may allow to bring the appliance down to energy class B103, but this is likely to be true only if combined with other options and for special design solutions. According to industrial sources, this solution is too expensive and does not allow enough savings to justify it.

Another option to improve the energy efficiency of vented dryers would be to combine them with heat pump technology. This would allow to bring the appliances to energy class A. However, as with exhaust air recovery, the “open system” means that issues like condensation in the exhaust air need to be considered. Solutions include replacing the electrical heat exchanger by the condenser of the heat pump system and placing the evaporator of the heat pump in the exhaust air system of the dryer. However, this would entail a significant increase if the price.

Exhaust air recovery

Combination with heat pump technology

¹⁰³ Palandre (2005)

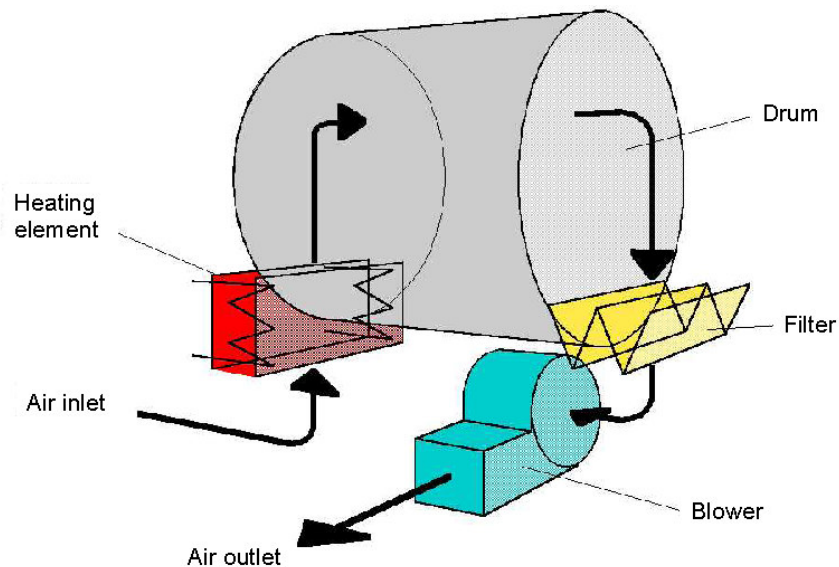

Figure 152: Air vented tumble dryer¹⁰⁴

In gas dryers, the heating element is a gas burner.

Low heat long duration
dryer option
(situation-specific)

As an option, some vented dryers may function as low heat long duration dryers, meaning that in this mode, their internal heat source is used only to maintain a minimum temperature inside the dryer. They rely on room temperature compartment air to remove the humidity from the laundry and could thus be considered external heat source dryers (see BNAT, below). In other words, the difference between drying in a low heat long duration dryer and on a clothes line is the mechanical rotation of the drum, which accelerates the drying process.

This option allows to reduce the electric energy consumption at the power cord but, depending on the situation, the total energy demand of the system may not be reduced, as the energy demand for space heating may also increase. Indeed, in heated rooms, the ambient air that is taken in to dry the laundry is replaced by outside air, which needs to be heated at room temperature, thus increasing the energy demand for space heating.

However, due to the little or lacking preheating of the process air, the drying process takes very long (three to four times longer than other dryer types, around 8 hours for a 6 kg load).

Furthermore, the large amount of intake air brings with it dust and lint, greying the laundry and since the laundry is tumbled inside the drum during the whole process, low heat long duration dryers cause more mechanical stress to the load.

Therefore, low heat long duration dryers should be considered as a possible option for southern areas/hot summer seasons, where no space heating is needed and for certain types of applications. It is a niche market, appropriate for only certain climates, people and situations.

Compact dryers

Compact dryers are prevalently air vented tumble dryers with resistive heat generation, although condenser types do exist. From a technical point of view, they share the problems of their full-size counterparts.

¹⁰⁴ Palandre (2005)

Compact dryers are less efficient than full-size dryers but occupy a different market segment.

Furthermore, they are less energy efficient than full-size dryers.

Compact dryers are generally much smaller and cheaper than full-sized appliances, making them interesting for a completely different segment of the market.

While gas-fired and heat pump versions of compact dryers are technically feasible (with limitations: current heat pump technology is very space consuming and will hardly fit inside a smaller casing), they would not be economic because of the combined and thus even smaller market share of compact dryers themselves and of gas / heat pump dryers.

Gas tumble dryers

Gas tumble dryers work similar to electric air vented tumble dryers, but the heat source is a gas flame. With the exception of heat generation, gas tumble dryers do consume electrical energy to rotate the drum, supply the control circuitry, etc. It goes without saying that a gas port is needed to operate a gas tumble dryer.

Gas tumble dryers are regarded as a proven and established type of technology, too.

In comparison to electrical dryers, gas tumble dryers have a slightly higher final energy consumption, but use primary energy for heat generation, thus avoiding conversion losses (during the electricity production process) and transmission losses (from plants to consumer) associated to electricity. It strongly depends on the country and thus on the generation of electricity and the source of gas whether generating heat by burning gas or by using electricity is more environmentally and/or economically beneficial. The modulating gas dryers technology may also help achieve reduced drying time (see BNAT).

Gas tumble dryers have a rather small market share in Europe, contrary to the US for example, where they are widespread. Possible reasons are the lack of infrastructure, the requirement that the installation be carried out by a professional, and safety concerns on the part of the customer.

From a manufacturer's point of view, gas tumble dryers are very differently to manufacture in comparison to electric operated dryers.

Condenser tumble dryers

In condenser dryers, the air is heated electrically as in an electric air vented dryer. Yet, instead of blowing out the humid air once it has passed through the laundry, the air moisture condensates in a heat exchanger. A heat exchanger is a device which brings into thermal contact two media of different temperatures without mixing them. Heat is transferred from the hotter to the cooler medium. In current condenser dryers, the hotter medium is humid air. Hot air can carry much more water than cool air. When the hot air is cooled, the moisture it carries condensates inside the heat exchanger, from where the water is removed by force of gravity and/or a pump into a reservoir or the drain. When the air has cooled down and dried, it is circulated through the electric heater again, and the cycle starts over.

Recently, some condenser tumble dryers have achieved a Class B Energy Label thanks to a combination of design features allowing to improve heat and mass transfers in the drum, limit heat losses and energy waste at the end of the cycle, as described in chapter VI.2.

Gas dryers do not allow energy savings but use primary energy (environmental advantages depending on country's electricity mix) and are a proven technology. Infrastructure and practical issues, combined with consumers concerns with safety may explain their small market share in Europe.

Class B air condenser dryers

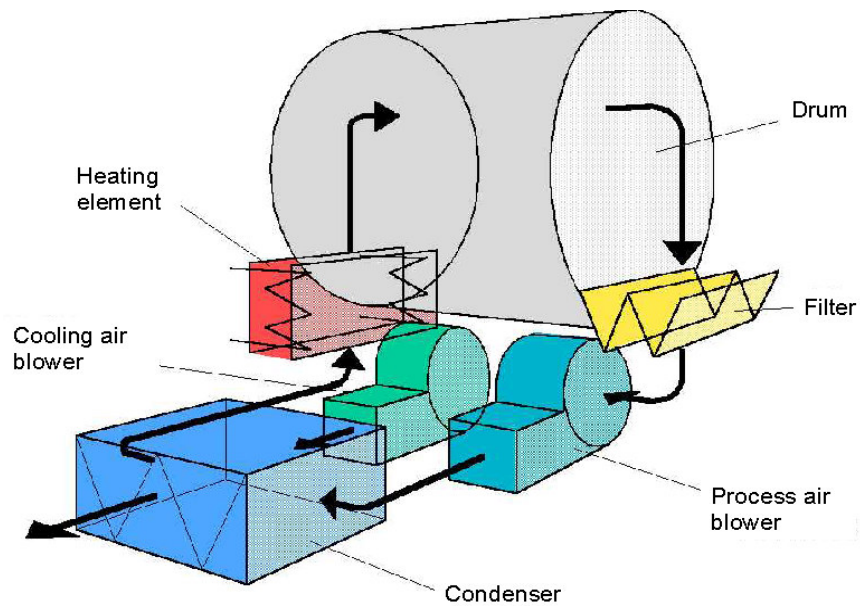

Figure 153: Condenser dryer¹⁰⁵

Heat pump tumble dryers

The operation principle of heat pump dryers is shown in Figure 154. The heating element and the humidity removing facility are the hot and cool sides of a heat pump, respectively (labelled "1", in the bottom part of the Figure). A heat pump generates heat on its primary side by compressing the working fluid (left, labelled "2"). The thermal energy is transferred to the air blowing through the laundry (middle, label "3"). That way, the working fluid cools down. On the second side of the heat pump, the cool working fluid is expanded (bottom right, label "4"). Due to the decreasing pressure, the working fluid gets colder. So does the secondary side of the heat pump, on which the water contained in the humid air condensates. The water is collected or drained. Once cooled and dry, the air is recirculated through the primary side of the heat pump.

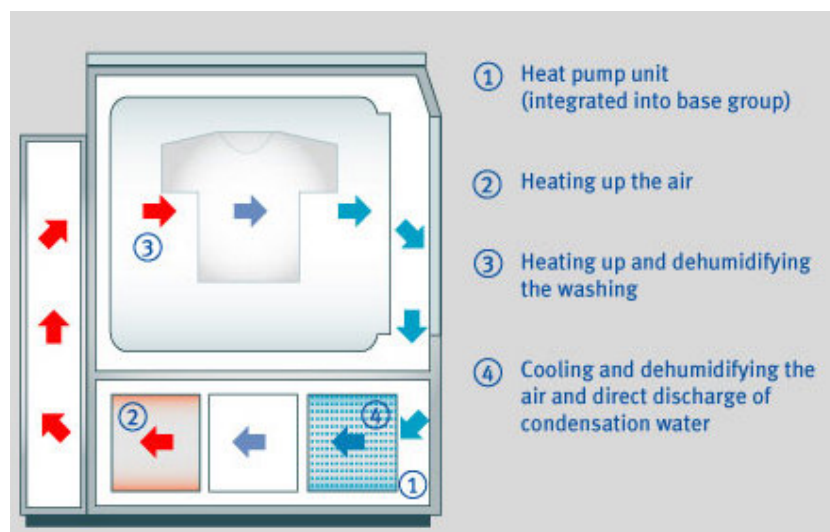

Figure 154: Heat pump tumble dryer principle¹⁰⁶

¹⁰⁵ Palandre (2005)
¹⁰⁶ Schultess website

Heat pump dryers allow up to a 40 % reduction of the energy consumption but may have longer drying times

Heat pump dryers allow up to a 40 % reduction of the energy consumption compared to traditional dryers (at 60% initial humidity level, for 6 kg loads). However, the current models may have longer drying times. According to industrial sources, the drying times vary from 100 to 140 min on the market for 6 kg loads.

Moreover, the use of a refrigerant (for the heat pump) imposes a closed loop which does not allow the condenser to be removable for cleaning. Due to the natural requirements of the heat pump regarding its surface area (shall be as large as possible), and owing to their relatively recent introduction on the market, there are thus considerations that the performance of heat pump dryers may not be guaranteed for the whole lifetime as lint accumulates on the surface and impacts the operating efficiency. Solutions that are being developed to work around this problem are detailed in section VI.2. The use of a refrigerant also implies careful management of safety and environmental issues, notably during the manufacturing process and at the end of life. The work in progress concerning refrigerant fluids is discussed in more details in section VI.2.

Lint accumulation may cause efficiency and lifetime reduction

The use of a refrigerant entails requirements on safety and environmental management

External heat source dryers

As their name indicates, these dryers do not generate the heat inside using a resistive heating element or a gas burner, but use external sources such as a house heating system or a district heating system. External heat source dryers can either be vented or condenser dryers. The heat energy is transferred from the external heat source to the process air using a heat exchanger. In a vented version, the warm air is blown out once humid. In a condenser version, there is a second heat exchanger (between the process and the ambient air) allowing for the condensation of the humidity as in a standard condenser dryer.

External heat source dryers should use of primary energy to optimize the ecobalance (depending on several parameters)

In order to reduce the environmental life cycle impacts, external heat source dryers should use primary energy for heating (e.g. gas, oil, thermal heating plants, etc.). The benefits come from using primary energy as opposed to electricity from the network, thus avoiding the low efficiency of electricity production (conversion losses) and the transmission losses on the network. However, the advantages depend on the country electricity production mix and network structures, on the energy source used (for example if renewable sources are used, like solar heating systems) and on the efficiency of the system used. Moreover, it should be stressed that the thermal energy consumption needed for the drying process does not differ.

In order to implement this solution, the electrical heater should be replaced by a heat exchanger wired to the external heating system. The dryer should also be placed close to the external heating source to minimize the losses.

It should be noted that without integrated heat pumps, the external heat source must provide a rather high temperature (100 °C, more than the usual central heating installation or solar thermal collectors provide). Otherwise, the dryer can only operate as air-vented dryer but not as condenser dryer which needs a higher temperature difference between the ambient (cooling) and the process medium (warm, inside the drum). Heat from the district heating network could be a viable solution because it is high tempered, but it comes at high pressure (12 bar) too, which needs to be reduced.

This solution is suited for areas in which room heating is needed over a long period during the year, like middle and Northern Europe.

District heat may fulfil condenser dryers' high temperature requirements

Table 100: Overview of best available dryer technologies

Vented dryers	Condenser dryers
Gas tumble dryers	Air condenser dryers class B
	Heat pump dryers
External heat source dryers	

Table 101: Overview of environmental, economical and practical advantages and drawbacks regarding BAT

Type	Technology	Advantages	Drawbacks
Vented	Gas	* Uses primary energy (environmental advantages of using primary energy depend on several parameters)	
		* Shorter drying times	* Gas port required
		* Proven and established technology	* Must be installed by a professional * Safety concerns on the part of consumers
Condenser	Class B air condenser dryers	* Proven and established technology	* Little room for improvement in energy consumption
Both	Heat pump	* Energy consumption reduction	* Higher component count
			* Higher costs
			* Health and environment issues due to use of refrigerant
			* Possible life expectancy reduction due to lint issues (closed refrigerant loop not allowing removable condenser)
			* Not implemented so far for vented dryers
	External heat source	* May use primary energy (environmental advantages of using primary energy depend on several parameters)	* Only high-temperature heat sources directly exploitable for condenser dryers (or costly heat pumps needed) * Requires system approach for correct implementation (more complex)

VI.1.3 Best Available Technologies outside the EU (product level)

Apart from adaptations necessary to make the appliances work with different (not 230 V) utility grids, the global state of the art is more or less equal.

Larger differences between the European Union and the United States exist in gas dryer technology. This is due to very different legal requirements regarding the exhaust / maximum emission values.

As a side note, there are different buying incentives regarding more efficient technologies in countries where the electricity grid does not offer higher-power connections for households as a standard. Technologies that consume less power are more likely to work with existing lower-power connections.

VI.2 State of the art (component level)

VI.2.1 Best available Technologies (component level)

In this section, the state of the art on component level concerning the BAT will be discussed.

Both vented and condenser dryers share a common set of components, for which optimization will be looked into. Technology-specific components will also be discussed.

Casing and door

The casing is the outer hull of the dryer. The door separates the dryer's interior from the outside, thus keeping the laundry, the moisture, and the heat inside the dryer. Depending on the type of dryer, there are different connectors for electrical energy, gas, fresh/waste water, supply/exhaust air etc.

For the casing, lacquer finished sheet metal is used. Sheet metal is rigid and acoustically insulating. It adds to the consumer's perception of quality and sturdy design. Production and lacquer finishing are estimated to be ecologically sound due to high quantities and optimized processes.

Work is also in progress on how to optimize the thermal insulation (improved geometry, new materials), however, according to industrial sources, the potential for improvement is limited.

Motor

All types of dryers have one electric motor driving the drum (forcing it to rotate). Depending on the type of dryer, mechanical energy is also needed for intaking and exhausting air and pumping water. Said energy is either provided by the same motor that turns the drum, or by additional motors/pumps.

In virtually all available dryers, single-phase capacitor-run induction motors are used. Inverter-fed three-phase permanent magnet synchronous motors are contemplated, but they are an economical question at current market prices. Such motor options include in particular brushless DC motor¹⁰⁷, brushless DC direct drive¹⁰⁸ motors and three phase motors, and their associated controls.

By optimizing the motor control strategy (adaptive acceleration, speed, positional control, and agitation patterns), the new technology offers possible improvements regarding the energy consumption, the uniformity of drying and the gentler treatment of the laundry. However, as additional circuitry is needed, this would increase costs.

The waste heat dissipated by the motor can be recovered and used as a heat source; the usefulness of this measure however depends on the efficiency of the motor and is lower for lower motor dissipation losses.

¹⁰⁷ Brushless DC motor (BLDC) are synchronous electric motors powered by direct-current electricity (DC) and which have an electronically controlled commutation system, instead of a mechanical commutation system based on brushes. Among other advantages, this reduces heat losses and the time needed to make the motor cool down.

¹⁰⁸ Direct drive means that the motor is mounted directly on the axis of the drum, without the traditional drive belt, which ensures low energy losses and better control.

Insulation of the casing and doors

Different type of motor, incl. brushless DC, brushless DC direct drive and three-phase motors

Optimized motor control strategy

Heat recovery motor

Two motors decoupling mechanical and thermal energy provision

Many dryers use a single motor for the agitation of the drum and the blower(s). The rotation of the drum is not always necessary, but the mechanical coupling of the two functions implicate that the drum always rotates when the blowers are on, the latter of which is necessary during longer periods of time than the former. It has been suggested that decoupling the two by using two motors may help achieve energy savings.

Drum

The drum is a hollow cylindrical vessel inside of which the laundry is situated during the drying process. The drum is perforated at the back in order to allow for airflow through the laundry.

Design optimization for the drum

The airflow through the drum (and thus through the load) is determined by the speed (number of rounds per minute, in rpm), the size, volume, shape of the drum and also the boring (number / shape of holes), so there are many parameters to consider. Current considerations used to optimize them are summarized as follows:

- The volume of the drum should be as large as the other components allow. Heat-exchange dryer cases are, for example, rather fully utilized,
- The distance the warm air covers on its way through the laundry should be maximized to ensure optimal humidity transfer, so the drum's air inlet should be positioned diagonally opposite to the air exhaust. This is especially efficient for partial loads, because there is less chance that the flow "misses" the load compared to an axial air flow,
- The air exhaust in turn should be located at the bottom of the drum which is advantageous especially for partial-load scenarios.

Improved insulation of the drum

A further challenge is to ensure optimal thermal contact between the heating element and the drum, and to insulate the drum to make sure as little heat as possible is lost to the surroundings while keeping the thermal capacity¹⁰⁹ at a manageable level. A small thermal capacity is especially important for the first heating phase and the final cooling-down phase in the drying cycle.

Optimization of number /mass of structure elements

A possible way to limit the energy consumption and time needed for drying is to reduce the number and/or mass of components to be heated. At the same time, the mechanical strength of the assembly must be guaranteed.

Resistive heating element

Resistive heating elements are heated by current flowing through them. The heating element can be "open coil" (with a large surface for optimal heat transfer to the intake air) or insulated. For details, please refer to Task 4.

The heating elements are the main consumers of energy in air vented tumble dryers and condenser dryers. The outer insulation serves to both keep the surface temperature within legal requirements¹¹⁰ and to minimize the waste heat. Yet, the amount of insulation cannot be increased at will because it influences the thermal capacity of the heating element assembly and thus the time needed to reach the maximum temperature and to cool down.

¹⁰⁹ The thermal capacity is a material-dependent parameter that is defined as the ratio of the heat energy input to the change in temperature the heat input causes in an object. An object with a large thermal capacity heats up and cools down more slowly to a given temperature, or – put the other way around – will get less hot (or cold) at a specific heat energy input than an object with a low thermal capacity.

¹¹⁰ The different legal thresholds depend on the metal used for the insulation of the dryer.

Little improvement foreseen from insulation and higher heating power for the heating element

The electric load rating of resistive heating elements is 2 to 3 kW, corresponding to the circuit breakers typically installed in households (10 or 16 A at 230 V). A higher heating power would reduce the drying time, but also make necessary a different electrical connection, and would result in higher laundry temperatures. To keep the temperature at levels tolerable for the laundry, a higher airflow would be necessary but this would result in noise levels that would not be acceptable to domestic consumers.

Modulating gas burners

Burner

The flame in gas tumble dryers is controlled to be either fully on or off. A half-rate state or modulating the flame to any arbitrary size would need different burners and a more complex control circuitry (see BNAT).

It must be noted that while all types of gas (natural gas, biogas, digester gas) could be used in the burner, today's burners cannot automatically adapt themselves to the fuel, and the manufacturer would need to be contacted to readjust the burner on site.

The burner generates about 350-400 m³ of hot air per drying cycle. To comply with European emission standards, burners operate in air excess. Modern burners use catalytic elements to limit the emission of NO_x.

Little improvement foreseen from higher heating power for gas burners

Burners are rated to up to 4.7 kW heating power, thus theoretically outperforming electric heating elements, which are usually rated 2 to 3 kW¹¹¹. Even higher values are technically feasible but would result in higher airflow and higher top temperatures, requiring more switching operations (which affects component life expectancy) and producing more noise.

Theoretically, energy consumption could be traded for drying time as in electrical low heat long duration dryers. There are however issues regarding the stability of flame, and the increased control complexity may not make sense economically.

Air inlets, outlets, and tubing

For condenser dryers, it is essential that the intake for cool air is insulated optimally from the heat present in the dryer to ensure a sufficient temperature gradient for the condensation to be performed efficiently.

Mix airflow system (air vented dryers)

One way to increase the efficiency in air-vented tumble dryers is to include a mix airflow system that (partially) circulates the process air, like two valves short-circuiting (partially) the exhaust (warm, partly humid air) and the intake (usually compartment air).

- at partial loads,
- towards the beginning of the drying process to minimize the energy consumption for the first heating of the heating element, and/or
- towards the end of the drying process when the laundry (and thus the exhaust air) is already rather dry.

Thus, the amount of air to be heated can be reduced.

Tubing

An effect that has to be taken into account is the pressure drop along tubing. The tubing should have a sufficient diameter in order to avoid pressure drops because these make the associated blowers work harder and consume more energy. The constraint in this respect is of course the amount of space available inside the dryer's casing.

Position of outlets

One interesting design option that offers additional flexibility in the installation process (but no energetic advantage) is the existence of differently positioned outlets.

¹¹¹ Pescatore & Carbone (2005)

Position of the reservoir

Condensate reservoir

In order to make it easier for the user to empty the condensate reservoir, it may be positioned in the top part of the dryer instead of the bottom (which is the natural choice because the condensate flows downwards following gravity). Therefore, a pump is needed to get the condensate from the low point where it emerges to the condensate reservoir located higher. While comfortable and additionally providing the service for external draining, the pump causes more energy consumption in the use phase. Furthermore, it is an additional part and increases the price and energy demand for production of the dryer.

Refrigerants

This issue is especially important for heat pump dryers. Refrigerants are not developed by the manufacturers themselves and therefore the innovative input comes from specialized industry branches. It is however clear that when the currently used coolant, R134a, is phased out, different refrigerants will come into usage.

Choice of refrigerants

The choice of the best adapted refrigerant to this application will take into account the following criteria¹¹²: the coefficient of performance¹¹³, the volumetric heating capacity¹¹⁴ (in kJ/m^3), the operating pressures¹¹⁵ and the direct environmental impact of the refrigerant (quantified by the global warming potential (GWP), in $\text{kg CO}_2 \text{ eq.}$).

For example, six refrigerants have been tested¹¹⁶ for heat pump applications and the following conclusions were drawn: They all have close theoretical performances (COP:5.5- 6).

- R-134a, R-152a, and R-407C, which belong to the hydrofluorocarbon (HFC) refrigerant group which is targeted by the Kyoto protocol because of high GWP.
- R-600a (isobutane), which is a hydrocarbon, hence is flammable, and is also explosive. It may be possible to use but safety requirements need to be fulfilled. This refrigerant is widely used in domestic refrigeration in Europe but not in dryers applications at the moment.
- R-744 (CO_2), which is known for its interesting properties in heat pump application – e.g. in high energy efficiency water heaters using heat pump systems developed by Japanese manufacturers but finding components adapted to this high pressure cycle for a reasonable price is still difficult today.
- R-718 (water), as in the BNAT mechanical steam compression which has advantages in terms of environmental impacts but requires a specific development of the compressor, especially concerning its cooling.

Heat exchanger

The thermal contact surface of the heat exchanger should be optimized, in order to guarantee the best transport of thermal energy from the hot to the cool side to allow vapour to condensate while not inducing excessive heat transfers (which would lower the temperature). In other words, it should be designed so that, at the condensation rate

¹¹² Palandre (2005)

¹¹³ This is the ratio between the heating capacity output at the superheater-condenser and the mechanical work of compression

¹¹⁴ This gives the energy delivered at the condenser by the displaced volume of the compressor (the greater this ratio is, the smaller the size of the compressor, for a given heat transferred capacity)

¹¹⁵ Depending on the levels of operating pressures (low < 1 MPa, medium <3 MPa, or high, up to 15 MPa), technological choices will differ and will have an impact on the mass, the availability and the cost of the circuit components

¹¹⁶ Palandre (2005)

Small plates and fins

needed, it ensures the least possible temperature losses. Moreover, it should fit inside the casing. As a compromise, the heat exchanger may have small-scale plates and fins to optimize the surface.

Air filters

Since the hot process medium is humid air coming from the drum filled with laundry, there are issues that lint covers the surface and makes the heat exchange less efficient. To avoid this effect, user-accessible air filters are in place, which have to be cleaned time and again to ensure optimal operation.

Heat pump

In general, the same aspects described for heat exchangers are true for the heat pump, too, except the linting issue is of more importance since the condensers cannot be removed. The air filters need to be even more effective, as manual cleaning cannot be performed. There are issues regarding the life expectancy of heat pumps for laundry dryers as they are just being introduced newly to the market by most manufacturers. It should be noted that an option found in the literature: pyrolysis cleaning, was not considered possible by industrials for heat pump dryers, as this would require too high temperatures (>300°C), which is not tolerable with the current technology and not pursued for the future.

Moreover, due to the losses that occur in the refrigerating system, the heat pump as a whole heats up during the drying cycle, so the warm side gets hotter, and the cool side gets less cold. Excess heat must be dissipated to the environment in order to stay within the operational range.

Control features

The foremost function of control features is to correctly detect the end of the drying cycle in order not to overdry the laundry and thus waste energy. Only simple and cheaper dryers still rely mechanical and electro-mechanical control today. The use of electronic systems in laundry dryers generally increases the energy efficiency in comparison to mechanical / electro-mechanical control because it allows more parameters to be taken into account and thus works better and more accurately. Greatest savings can be achieved in partial load scenarios. Electronic systems are however more expensive than simpler units.

Time v. automatic (humidity) control

Simple dryers only use only time control to determine when to turn off the dryer. More sophisticated dryers may have a number of sensors for different parameters and automatically evaluate how to optimize the end of the drying process to the humidity left in the clothes based on parameters measurements. The dryer selected for the base case includes automatic humidity control.

For example, resistance¹¹⁷ sensors integrated in the drum are used to obtain an estimate for the amount of laundry inside the drum and its moisture content. In Figure 156, the working principle of laundry resistance measurement is depicted. It is shown that there are flaps inside the drum that bear the sensors. The sensors are contacted from the outside by sliding contacts. Figure 155 shows the correlation between the resistance of the load and the moisture content. Temperature sensors located at the drum inlet and outlet may also provide the control system with data. For additional information, please see Task 4.

¹¹⁷ or conductance, one is the reciprocal of the other. The resistivity is the resistance per length unit.

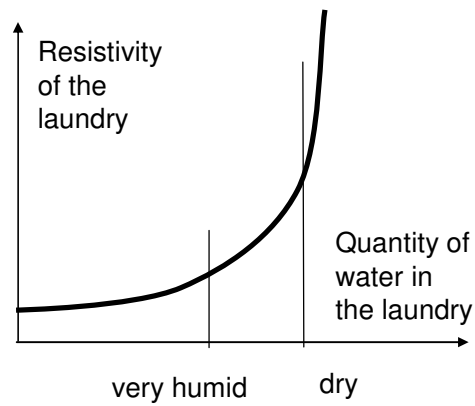

Figure 155: Laundry resistance vs humidity

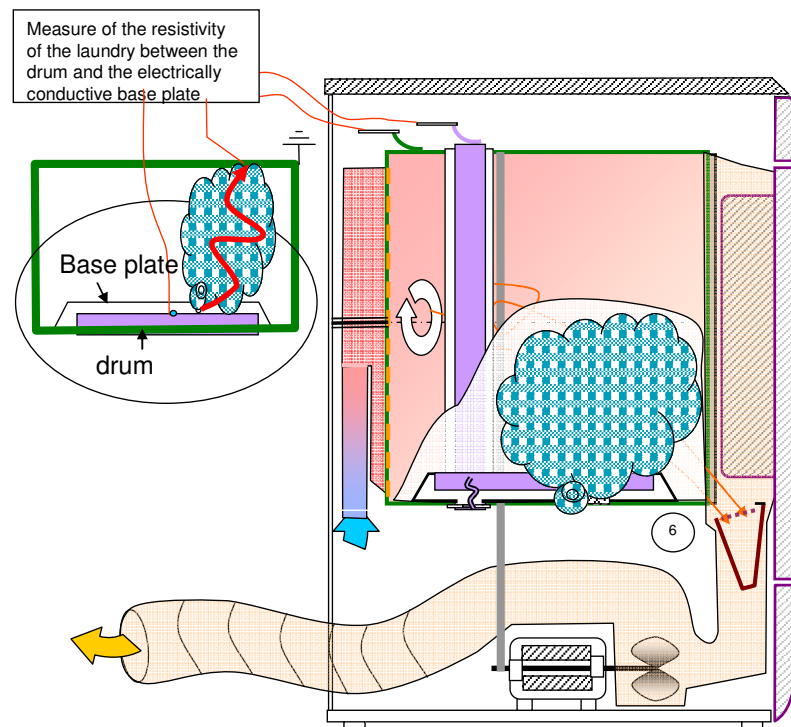

Figure 156: Working principle of laundry resistance measurement

Weight sensors
Intelligent load control
systems

Weight sensors to directly measure the weight of the laundry are currently not built into the dryers, but could further optimize the efficiency at partial load by influencing consumer behaviour. Furthermore, intelligent load control systems could adapt the drying process to the load inside the dryer, thus optimizing the performance (this has advantages only at partial loads).

Water inlets, outlets, and tubing

Concerning water inlets and tubing, and radiators, no industry expert has disclosed any relevant information concerning these items.

Combined drying programme programme

Programmes available

As showed in previous tasks, drying at partial loads reduces energy efficiency. Combined drying programmes, which allow users to dry different types of laundry at the same time, may thus help reduce partial load drying and thus contribute to energy savings. However, this has obvious limitations since depending on the type of laundry, differentiated care may be required.

User interface

The controls available to the user range from simple rotary knobs for programme selection and a visual indicator signalling the end of the drying cycle to LCD-equipped menu-driven interfaces.

End of programme signal

Visual/acoustic signals to inform the customer of the end of the programme allow to limit the time appliances are left in standby mode.

Weight sensors

If weight sensors were built into dryers, a signal informing consumers that their dryer is only partially loaded may influence their behaviour, helping them to optimize the loads they dry and thus improve energy efficiency.

Load control signal

Signal for cleaning condenser (condenser dryers)

For condenser dryers, a signal to inform the user that the condenser needs cleaning may be an option, as it would contribute to achieving optimum energy efficiency and lifetime for those dryers.

LCD control display

It should be noted that LCD displays allow sophisticated information and controls for the consumers but also induce environmental impacts during the life cycle of the product, especially because of their production phase and end of life management requirements.

User impact on initial moisture content (selected spin drying speed in washing machines)

User behaviour

First of all it must be noted that mechanical dehumidification of clothe is very efficient (high rpm spin in washing machine). Users who employ a laundry dryer should be educated to always employ an appropriate spinning speed available on their washing machine, depending on the climate zone they live in. A rule of thumb¹¹⁸ (only considering technical factors) may be to consider that consumers always use the highest spinning speed, but a more complex numerical model may be used, such as the one presented in the EuP study Lot 14, including the available appliances and typical usage scenarios in regard to the climate zone.

User demand on final moisture content

The user expectancy plays an important role regarding the residual moisture content of the load. Even if the residual moisture is well within standard values, the user will probably think the load is still too wet, owing to the fact that on the user's relatively cool hands, moisture from the warm, damp air inside the drum will condensate. If the user cannot be persuaded by means of education that the load is dry enough and be kept from overdrying and wasting energy, a method must be developed to make sure the air inside the dryer is cool enough to avoid condensation of moisture on the user's hands. It could be an option (for users whose time and space permit it) to use a drying programme with higher final moisture and then put the laundry on the clothesline to save some energy. Then again, for many users this is not feasible due to time and space constraints.

¹¹⁸ Palandre (2005)

VI.3 Potential application for the base cases - List of design options

VI.3.1 Proposed design options

Since the production of current-day dryers is optimized under the criterion of “economy of scales” (dryers being mass produced), the implementation of design options would entail additional production costs, which may then be (either partially or totally) passed on to consumers.

It is an incentive for manufacturers to pick (and possibly combine, see section VI.3.2) those options that allow for an improved classification of the product according to the energy labelling standards as shown in Figure 157, since that is what consumers directly see at the point of sale and thus contributes to justifying higher purchase prices.

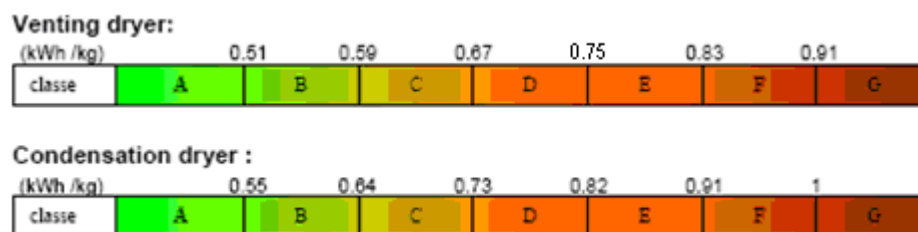

Figure 157: Energy labelling of laundry dryers¹¹⁹

In the following table, the minimum energy savings necessary to improve from one energy band to the next (“bottom to bottom”, i.e. the next band is barely achieved starting from the lowest possible level in the current band) in Wh/kg load are listed.

Table 102: Minimum improvement needed to achieve a better label (in Wh/kg load)

	F to E	E to D	D to C	C to B	B to A
Vented	80	80	80	80	80
Condenser	90	90	90	90	90

In Table 103, a number of design options, the expected potential energy savings (in Wh/kg load), and the estimated additional costs in the purchase price for the customers¹²⁰ (in euros) are listed. As a basis for the table, a study conducted by the German Energy Agency (Deutsche Energie-Agentur, DENA) was used. This table was compiled in 2005 and reviewed (the Figure s updated and filled in where possible) to today’s standards for this report with the help of industry experts. Furthermore, options not present in the original table but identified in the course of this Preparatory Study were added. The table must be viewed under the perspective of traditional air vented (electric) and condenser dryers being the base cases (energy savings and additional costs are calculated with the base cases as a reference). It should be noted that applicability to condenser dryers includes air condenser dryers and heat pump condenser dryers.

¹¹⁹ Palandre (2005)

¹²⁰ Assuming that all the increase in production costs are directly passed on to consumers.

Table 103: Design options

Design option	Details/Notes	Energy saving potential (in Wh/kg load)	Additional costs for consumers (in euros)	Applicability
Heat pump condenser dryers		270-350	300-360	Condenser dryers
Heat pump technology for vented dryers	Combination of air vented dryers with heat pump technology	150	250	Vented dryers
Gas dryers	Costs do not include installation at the site.	0	200-500	Vented dryers
Exhaust air heat recovery	Preheating incoming air with exhaust heat	50	50-150	Vented dryers
External heat dryers	Using house or district heating systems as a heating source. Costs do not include installation at the site.	NA	200-400	All technologies
Low heat long duration option	Only in specific situations	NA	0	Vented dryers
Improved insulation	Through improved geometry and materials for the casing, drum, tubing, etc. to reduce heat losses. Savings depend on the technology (air condenser>heat pump>air vented)	10-40	40-70	All technologies
Mix airflow system	Partial recirculation of process air cannot be combined with heat recovery systems	10-50 (50 for partial load)	10-60	Vented dryers (partial load)
Improved motor concept (incl. control)	e.g. Inverter-fed three-phase permanent magnet synchronous motors, permanent magnet DC motor, general optimization of motor control strategy. Less savings if combined with heat recovery motor.	25	25	Condenser dryers
		25	20	Vented dryers
Two motors	Amounts to decoupling of mechanical and thermal energy	NA	NA	All technologies
Heat recovery motor	Recovering motor heat losses for drying the laundry (integrated motor, humidity insulated). Only suitable for high-loss motors	10	20	Condenser dryers
		10	10	Vented dryers
Combined drying programs	To enable drying different clothe types together to optimizethe loading	20-50	10-20	All technologies (partial load)
Improved sensor and control systems	Load control (acoustic/visual signal)	20-100	10-50	All technologies (partial load)
	Intelligent load control	5-50 ¹²¹	50	All technologies (partial load)
	Humidity control (v.time control) allowing to avoid overdrying. The base cases selected already include humidity sensors.	20 ¹²²	30	Condenser dryers
		20	20-90	Vented dryers
Technology-specific improvements	Improved gas burner, heat exchanger, or heat pump designs	NA	NA	respective technology
Optimized process and system design	Achieved by the best performing appliances on the market, compared to average products	50	95	Condenser
		45	75	Vented Dryer

¹²¹ Based on the range of appliances on the market

¹²² Assuming that laundry in time controlled dryers has a 2-4% lower final moisture content compared to humidity control.

VI.3.2 Combinations of design options

Rationale for combination

As seen from the preceding table, the implementation of one single design option hardly suffices to gain an energy class.

In order to achieve even higher savings than with one option alone, the question is which options can be combined.

It must be noted that with current technological means, production lines and in today's marketplace, even single options may result in a considerable increase in end-user price, and the combination of two or more options is thus likely to be even more expensive.

Nevertheless, Table 104 gives an overview which design options can be combined. It should be stressed that some options are only applicable for partial load, therefore their combination is only possible in partial loading conditions (see real life basecase).

Table 104: Possible combinations of design options

Design option	Heat pump	Gas burner	Insulation	Mix airflow system	Exhaust air heat recovery	Motor concept (incl. control)	Heat recovery motor	Combined drying programs	Sensor and control systems	Technology-specific improvements
Heat pump										
Gas burner										
Insulation	x ¹²³	x								
Mix airflow system			x							
Exhaust air heat recovery		x	x							
Motor concept (incl. control)	x	x	x	x	x					
Heat recovery motor	x ¹²⁴	x	x	x	x	x ¹²⁵				
Combined drying programs	x	x	x	x	x	x	x			
Sensor and control systems	x ¹²⁶	x	x	x	x	x	x	x		

¹²³ Heat pump with lower efficiency gain (reduced effect)

¹²⁴ Heat pump with lower efficiency gain (reduced effect)

¹²⁵ Reduced effect

¹²⁶ Technically possible but industrial experts currently consider the combination of heat pump dryers and humidity control (and a fortiori more sophisticated controls) too expensive

VI.4 Best Non Available Technologies

In this section, the best non available technology on product level is discussed.

VI.4.1 Best Non Available Technologies (product level)

As indicated in section VI.1.3, the state of the art is similar all over the world.

Modulating gas dryers

Gas dryers may allow to deliver reduced drying times because they do not have the same upper power limit that is associated with the line cord power of an electric dryer. Through heat modulation in function of the moisture level of the load, energy savings (up to 25% for small and medium loads), reduced drying times (up to 35% for large loads with 10-15% energy savings) and reduced fabric temperatures may be achieved¹²⁷. *It should be noted that these savings have been achieved for American gas dryers with a heat input of 11.7kW (40,000Btu) (typical European gas dryer have a 3kW rating), with a capacity of 6.8 kg, but with a drum larger than that of European 7 kg dryers.*

However, implementing a time saving system into a gas dryer is not as simple as merely increasing the input rate and may entail higher production costs. Work has been undertaken¹²⁸ to match (or modulate) the heat input rate to the moisture level of the load.

Indeed, airflow considerations are critical to ensure proper burner performance and to prevent excessive inlet grill air temperatures. As explained in section 3, if the gas input and airflow rates are not properly balanced, excessive drum inlet temperatures will arise and result in the risk of clothing damage. This is especially true as the clothes begin to dry. The solution developed to ensure an even and appropriate airflow implies two inshot burners configured in such a way that they fire into an oval shaped combustion funnel before turning up the rear duct and then entering the drum. The airflow is induced by a variable speed located downstream of the dryer, which allows multiple airflow rates to match the modulating input rate.

Moreover, installation variations may be significant and must be compensated for. A system able to detect installation variations and adjust the flow accordingly, using a pressure switch in the exhaust flow stream from the dryer, was developed.

Finally it must be determined that the clothes are, in fact, wet. For that, a refined control strategy was implemented. Adding to usual conductivity strips (humidity sensors), a sensor measuring the temperature in the exhaust was set up. Indeed, with a known flow rate, the temperature in the exhaust gives an indication of the amount of moisture inside the drum. This signal is used to determine when to perform the first and second modulation steps. This temperature, combined with a signal from a humidity sensor in the exhaust, is then used to determine the end of the cycle.

There is currently no product using this technology on the market. No information was found as to whether industrials currently develop this option.

Modulating gas dryers may allow shorter drying times and energy savings

No simple changes possible thus possible high production costs

Ensure optimized airflow to control inlet temperature

Compensate installation variations

Implement a sophisticated control system

No such product on the market and no indication that industrials currently research this option in Europe

¹²⁷ Pescatore & Carbone (2005)

¹²⁸ Pescatore & Carbone (2005)

Microwave dryers

Just as in microwave ovens found in kitchens, microwave dryers employ electromagnetic waves to directly heat water. The water vapour is removed by a stream of air and blown out to the atmosphere.

Electromagnetic waves are emitted by magnetrons (below the drum in Figure 158) and directed at the laundry via antennas (also known as waveguides). The electromagnetic waves interact with the water molecules stored in the laundry, while passing mostly freely through the laundry, thus hardly heating it. The water vapour is removed by a stream of air and blown out to the atmosphere (bottom left part of the Figure).

This is a fundamentally different principle than in electrically / gas heated vented, condenser, or heat pump dryers, where hot air transports the thermal energy needed to evaporate the water.

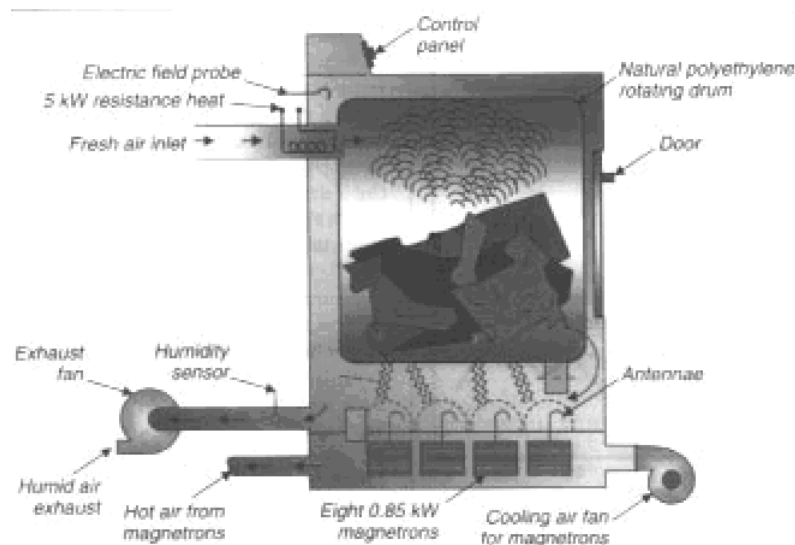

Figure 158: Microwave dryer principle¹²⁹

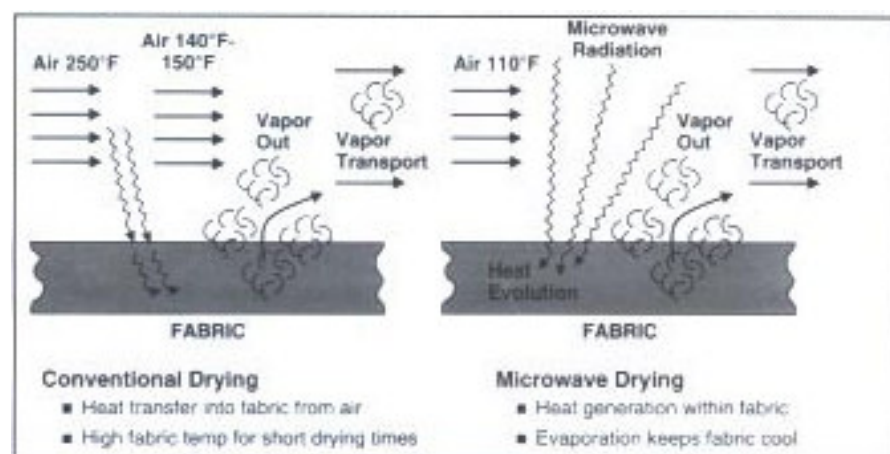

Figure 159: Transport of thermal energy in conventional and microwave dryers

¹²⁹ IAM

Microwave dryers may allow shorter drying times but no energy savings

The amount of energy needed to heat up water is physically determined and unchangeable, therefore microwave dryers theoretically offer no energetic advantage. With the low efficiency of current magnetrons (microwave generators) which tops at about 70 % or even if they reached 90 %, microwave dryers would consume about as much energy as conventionally (resistively) heated tumble dryers¹³⁰. The only advantage over conventional technologies is a possible reduction in drying time.

Stringent safety requirements must be fulfilled to avoid risks of fire and guarantee acceptable levels of radiation emission

In order to improve the energy efficiency, heat recuperation from the exhaust air is not an option as with air vented dryers due to the risk of humidity condensing in the hypothetical exhaust heat exchanger. Hot air from the magnetron(s) could be used however, for additional drying. In fact, the principle diagram even shows a resistive heating element at the air intake (top left part of Figure 158) to speed up the drying process. Reports indicate that a heating element is of importance especially in the last drying phase when there is hardly any water left in the laundry, because this is when the electromagnetic excitation of water molecules performs worst, and much radiation is absorbed by the clothes.

Another common problem associated with microwave technology is that the clothes are dried irregularly. Moreover, if they are not wet enough when put in the dryers, there may be risks of fire. Additionally, microwave dryers must be shielded to limit the emission of radiation. Sensors and complex controllers are usually required to avoid any damage to the load by sparks which are caused by metal objects (zippers, neglected coins and other pocket contents), thus entailing significantly higher production costs and causing significant inconvenience to users. Regarding these issues, there are also health and safety concerns from consumers.

A new microwave concept is claimed to prevent arcing and dry clothes evenly, without entailing excessively higher production costs

Now, a company has further developed microwave drying technology so that clothes are dried evenly and no arcing occurs along metal objects inside the drum. Furthermore, the company states its concept is largely based on existing dryer components (apart from the microwave source), making unnecessary the production of new and differently shaped components.

No such product on the market and no indication that industrials currently research this option in Europe

As previously mentioned, test data indicate that microwave dryers are about on par in terms of energy efficiency with conventional vented dryers (thus offering no benefit in terms of energy efficiency) and the stated problems have so far kept manufacturers from putting any domestic microwave dryers on the market. Our research did not indicate that industrials are currently working on this technology in Europe.



¹³⁰ Nehring (2008)

Figure 160: Prototype countertop microwave dryer¹³¹

Vacuum dryers

To lower the boiling point of the water stored in the laundry, the pressure inside the drum is lowered. Depending on the quality of the vacuum, the boiling point of the water can be lowered to room temperature or even lower, making it possible to evaporate the water without applying additional heat.

It is seen from Figure 161 that, at room temperature, the pressure required to evaporate all water is around 2 kPa, which is technically achievable, but results in a complex and costly design. Moreover, at low pressure the heat needed to evaporate the water is usually taken from the ambient room, thus increasing demand on space heating.

On the other hand, with higher temperatures, the required pressure is higher, but additional heating elements are needed.

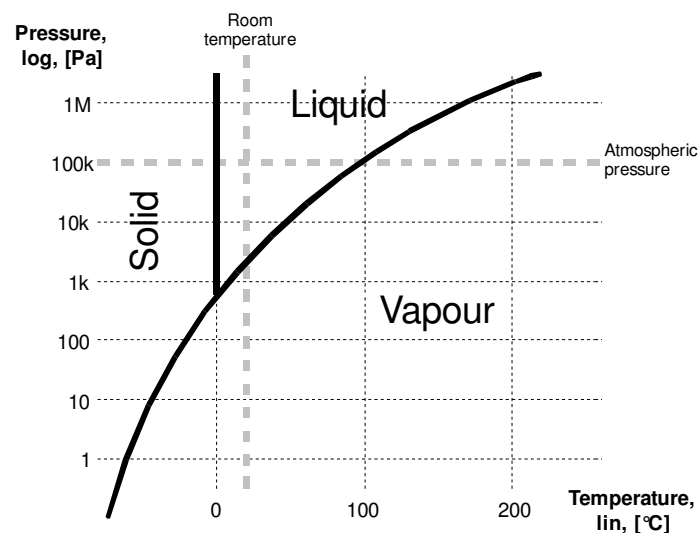

Figure 161: Phase diagram showing the aggregate states of water as a function of pressure and temperature¹³²

Vacuum dryers may claim around 30% energy savings but their complexity may entail prohibitive production costs

No such product on the market and no indication that industrials currently research this option in Europe

Thanks to the greatly reduced need of additional heat to dry the laundry, about 30 % energy savings may be expected¹³³, compared to traditional dryers. Moreover, this technology can theoretically be combined with others like heat pumps or mechanical steam compression to achieve even greater savings.

However, vacuum dryers have a radically different design compared to existing dryers. The biggest challenge is to make the drum airtight at the low pressure that is needed for room temperature drying, implying pressure vessels for the clothes and a combination of pumps and compressors. The complexity of the circuit may thus entail prohibitive production costs.

No such products are found on the market and there is no indication that industrials are working on this technology according to our research.

Mechanical steam compressor dryers

In mechanical steam compressor dryers (Figure 162), the air is purged from the system as steam is generated, which then acts as the process medium.

¹³¹ Gerling (1998)

¹³² Source: <http://www.lsbu.ac.uk/water/phase.html>, adapted

¹³³ Wilhelm (1995) claims a 40% reduction in comparison with traditional dryers at the time, which were about 10% worse than today.

There are four distinct phases in drying with mechanical steam compressor dryers. During the first phase, the structure and the laundry are heated to 100 °C (12-15 min). Then, the water in the linen starts to evaporate and the air inside the drum is progressively displaced by steam (c.a. 2 kg water vapour per kg of dry air). In the third phase, all air has been replaced by steam. Note that only a small part of the water stored in the laundry has evaporated yet. A part of the steam atmosphere is now compressed in the compressor (similarly to the process medium in a heat pump dryer). The heat thus generated is used to heat the rest of the atmosphere blown through the superheater. The heated air is blown into the drum again, where it is recharged with moisture. The compressed partial stream is expanded, and the humidity condensates. Then, the cycle starts over. In the fourth and last phase, the humidity is close to its target value. The compressor stops, and air is let in through the four-way valve to get rid of the last remains of steam, and to cool down the laundry to a reasonably safe temperature so the user can take it out.

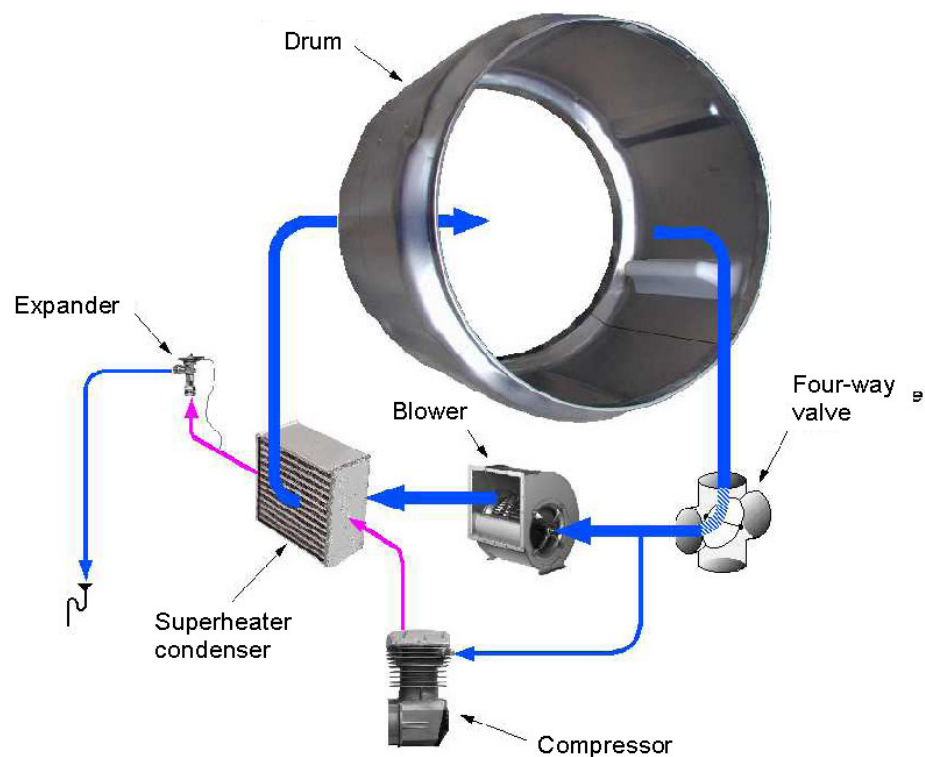

Figure 162: Mechanical steam compression drying principle¹³⁴

Mechanical steam dryers may allow energy savings and shorter drying times

Ecologically compatible refrigerant (water)
Condenser removable for cleaning

This technology claims energy savings similar to those achieved with heat pump condenser dryers, associated with halved drying times thanks to reduced sensible heat losses during the condensation process¹³⁵, improved heat and mass transfers and savings possible on ventilation due to the use of water vapour¹³⁶ from the clothe as the thermodynamic fluid. Adding to that, mechanical steam compressor dryers have the advantage of an ecologically compatible refrigerant (water steam) and allow for the condenser to be removed for cleaning, thus limiting linting and lifetime reduction issues.

¹³⁴ Palandre (2005)

¹³⁵ Indeed, the vapor is then in saturated state.

¹³⁶ There is no more air resistance so heat and mass transfers are improved, and the thermal capacity of steam is about twice that of air, thus allowing to increase the heating capacity at constant mass flow rate and enabling to save on ventilation means.

Special components need to be developed and allow for mass production at reasonable costs

Mechanically robust dryers structures required

Adapted components are under development but no industrials are currently associated to the process

Not adapted to all types of fabrics but versatile dryer solution under development

There are, however, some problems associated with mechanical steam compressor dryers. First, due to the usage of water steam as process medium, appropriate components (compressor, “superheater-condenser” heat exchanger) must be developed, which are more expensive than staple components, and mass production must be possible at reasonable costs. Moreover, mechanically robust structures for dryers are needed to avoid tightness issues which would reduce energy efficiency. So far, only top range dryers (thus more expensive) have the necessary properties. Furthermore, the use of water steam also indicates that drying is performed at high temperatures (90 °C and more), which is inadmissible for many kinds of laundry and garments (delicate clothes, imprinted logos). So far, tests¹³⁷ show that cotton and polyester cotton do not suffer any pigmentation denaturing but this is not true for more delicate fabrics. A versatile dryer, which could work either as a traditional condenser dryer or as a mechanical steam dryer is under study¹³⁸.

Currently, mechanical steam compressor dryers are on the verge of leaving the breadboard stage, as components are being developed¹³⁹ (in particular a new kind of compressor) that allow for the technology to fit into a standard-size casing with reasonable noise levels. However, no industrial is reported to currently work with the laboratory developing the components.

Table 105: Overview of environmental, economical and practical advantages and drawbacks regarding BNAT

Type	Technology	Advantages	Drawbacks
Vented dryers	Modulating gas dryers	* Energy savings	* Specific components to be developed and mass produced
		* Shorter drying time	
		* Reduced fabric temperatures	
Condenser dryers	Vacuum	* Energy savings	* Complex components, thus expensive
		* Reduced drying temperature	* May increase energy demand for space heating
	Mechanical steam compression	* Energy savings	* Specific components (especially compressor), thus expensive
		* Shorter drying time	* High drum temperatures (may harm delicate laundry)
	* Ecologically compatible refrigerant (water)	* Mechanically robust dryer structure required, thus expensive	
Both	Microwave	* Shorter drying time	* No energetic advantage
			* Health and safety issues requirements (shielding of electromagnetic waves, detection of metal components against risk of fire)

VI.4.2 Best Non Available Technologies outside the EU (component level)

As indicated in section VI.1.3, the state of the art is very similar all over the world.

VI.4.3 Best Non Available Technologies (component level)

The components used in dryers considered BNAT are still a subject to research and development efforts by the manufacturers. Therefore, one cannot identify a current “state of the art”.

¹³⁷ Ecole des Mines Centre for Energy studies (2008)

¹³⁸ Ecole des Mines Centre for Energy studies (2008)

¹³⁹ Ecole des Mines Centre for Energy studies (2008)

VI.5 Conclusion

This task aimed at identifying technical options available to improve the environmental performance of laundry dryers, and in particular their energy efficiency. Based on data from the literature and exchanges with experts, a first overview of their potential advantages in terms of economical and environmental benefits is provided. For design options and combinations identified and further selected, the improvement potential in terms of energy savings and life cycle costs will be estimated in task 7. A sensitivity analysis on major parameters, including electricity costs, will be performed in task 8.

The current situation regarding the best available technology in laundry drying is as follows: Vented tumble dryers (both electrically heated and gas burning) and condenser dryers with air as the cooling medium are established on the market. Within the price segment, most savings that currently make sense in an economical and energetic way have already been realized (though energy prices are rising and may turn the tables). Table 103 summarizes the different design options available for each of these types of dryers, specifying their estimated energy saving potential and additional costs to consumers, and Table 104 specifies which options can be combined in order to achieve an even better performance. Table 100 provides a qualitative overview of the environmental, economic and practical advantages and drawbacks of the BAT identified at product level.

As for BNAT, interviews conducted show that industry experts are generally sceptical when it comes to radically different technologies that are not on the market yet. Most of the concepts identified have been under study for ten to twenty years, and still have not reached the market yet. Little indication of current dynamic research work on these technologies in Europe was found, with one company working on microwave technology and a research facility on mechanical steam compression. It was not suggested by any interviewee that the technologies listed as best not available in this report are bound to take the market by storm in the next few years in the face of established, producible, and affordable alternatives.

Annexes to Task 6

P References

- Andrews G.T. (2007) *Even-heating microwave technology*, Appliance magazine - March 2007, Gama Microwave Technology Ltd
- Bush E. (2006) *Tests and promotion of energy-efficient heat pump dryers*, Swiss Agency for Efficient Energy Use (S.A.F.E.)
- DENA (2005) *Revision of the Energy Labelling System*, Final Report
- ENEA (2007) *Preparatory study for Eco design requirements of EuPs – Lot 14: Domestic dishwashers and washing machines*, draft final report prepared for the European Commission, DG-TREN, July 2007, available at: <http://www.ecowet-domestic.org/>
- Gerling, J. F. (2003) *Microwave Clothes Drying – On the Verge of Commercial Reality*
- Nehring (2008) *Technical analysis of laundry dryers with microwave*, BSH
- Palandre (2005) *Evaluation of high energy efficiency technical solutions for domestic dryers – Conception and modelling of a highly humid air mechanical compression dryer*, PhD. Thesis
- Pescatore, P. and Carbone, P. (2005), *High Efficiency, High Performance Clothes Dryer*, TIAX final report to Department of Energy
- Kesselring, J.P. and Smith, R. (1998) *The microwave*, IAM (International Appliance Manufacturing)
- VHK (1995a) *Driers: Long term efficiency targets, a technical and economic analysis*, Background report 8 for the Group for Efficient Appliances (GEA) working group –European Energy Network (EⁿR)
- VHK (1995b) *Washing machines, driers and dishwashers*, Final report for the Group for Efficient Appliances (GEA) working group –European Energy Network (EⁿR)
- VHK (2005) *Methodology Study Eco-Design of Energy-using Products (MEEUP)*, Van Holsteijn en Kemna, final report prepared for the European Commission, DG-TREN, Delft, 28 November 2005; available at: http://ec.europa.eu/enterprise/eco_design/relactiv.htm
- Wilhelm, L. (1995) *Process and device to dry laundry and the like*, US Patent 5430956

Q Summary of comments from stakeholders

Submitted by	Comment	Response
31/10/2008 S.A.F.E. (Swiss agency for efficient energy use)	In chapter 3.1 (BAT/component level) HP dryers are treated as if they were just one of many small efficiency improvements. On the other hand heat pump is the only technology with really huge saving potential up to and even over 50% (Topten-listings). We suggest heat pump technology to be treated as the first and most important saving technology element in the BAT part. In table 4 this is listed correctly. In chapter 6 Conclusions HP dryers are not even mentioned. This seems not to be adequate to the huge saving potential. Prices of HP dryers have diminished substantially in the last few years and will do so further, so this seeming obstacle to the spreading of this technology will diminish in the next years.	Task 6 aims at identifying all technical options available to improve the environmental performance - and in particular the energy efficiency - of laundry dryers. Based on data from the literature and exchanges with experts, a first overview of their potential advantages in terms of economical and environmental benefits is provided but it is not possible to draw strong conclusions or influence their presentation before a proper analysis of the life cycle environmental impacts and costs is carried out, which takes place in task 7. Only then can conclusions be drawn, based on objective quantitative data. This point has been added both in the introduction and conclusion of the task so that readers are not mislead.
31/10/2008 S.A.F.E. (Swiss agency for efficient energy use)	Swiss government ...is considering to set labeling class A as a minimum efficiency performance standard (MEPS) for laundry dryers from 2012 onwards (in consultation process). This means that only HP dryers would be on the Swiss market in a few years. The development of models and prices in the last years is very promising.	This will be taken account in task 8 when considering possible policy measures.
31/10/2008 GAMA Microwave Technology Ltd., UK	The company has further developed microwave drying technology so that no arcing occurs along metal objects inside the drum. Furthermore, the company states its concept is largely based on existing dryer components (apart from the microwave source), making unnecessary the production of new and differently shaped components.	The appropriate section has now been completed to mention this technology improvement.
31/10/2008 Natuur en Milieu	Chapter 2, p.11 In the last sentence was written: "However, this would entail a significant increase in the price". In this study the price increase itself is not so important but the comparison with the savings. Chapter 4, p.31 Next to energy saving potential and costs for consumers a column with savings for consumer should be added (with a range due to different prices of electricity). The present columns cannot be compared. Chapter 3, p.19, 20,.. It is difficult to judge what the potential is of different proposals s only	In this section, options are discussed mainly with regards to their technical description and impact on production costs which can be found in the literature. The life cycle cost analysis (properly taking savings into account) will be performed in task 7. The evaluation of the environmental impacts and life cycle costs (LCC) of these options and their combinations will be performed in task 7, and a sensitivity analysis on major parameters will be carried out in task 8.

Submitted by	Comment	Response
	qualitative remarks are made ("improvement is limited"). More quantitative information is necessary.	
	Chapter 6, p42 The conclusion that the savings that make sense from an economical and ecological point of view are made is premature. Energyprices are rising so economics are changing. Secondly a laundry dryer is one of the most energy consuming equipment in a household and if we take the climate problem serious improved laundry dryers are necessary and ambitious minimum requirements are needed.	Ok. The sentence has been changed to mention the rising energy prices. The second part of the comments, on policy measures needed, will be addressed in task 8.
31/10/2008 Natuur en Milieu	Chapter 2, p.12 The option of low heat-long duration is easily given up without proof of the possible disadvantages. Chapter 4, p.31 Why is not a figure used for "low heat long duration option" as this can give large savings with no costs. In the discussion about climate options costs per ton CO2 are used to compare the different options. We propose that these calculations are also made for the different options as not only costsavings for consumers are important. These figures can be important to define minimum requirements.	It is explained that this option is highly dependent on the specific cases (especially ambient conditions) where it is used, this is why it is not studied further in this study. Moreover, as stated above, sensitivity analyses on major parameters, including electricity prices and electricity mix, will be performed in task 8.
31/10/2008 Natuur en Milieu	Chapter 4,p.31 Why no figures about costs of improved gasburner, heat exchanger or heat pump deigns are added	Figures from the literature were added where available.
31/10/2008 Natuur en Milieu	Chapter 2, p.13 As the production of electricity has a maximum efficiency of 60% (not taking into account distribution losses) gas tumble dryers have always a lower energy consumption if gas is available. So the wording of the authors in the first sentence should be changed.	Ok. The wording has been changed: The <u>final</u> energy (available at the user's home to be converted into useful energy used by the appliance) needed by gas dryers to dry one kg of laundry is slightly higher than that of electric dryers, even though they have a lower <u>primary</u> energy consumption.
31/10/2008 Natuur en Milieu	Chapter 2, p.18 What does "very different judicial requirements" mean and how does this affect the emission values?	This means that there are different legal requirements on maximum emission values. The wording has been changed.

Submitted by	Comment	Response
31/10/2008 Natuur en Milieu	Chapter 3, p.21 Do the present heatexchangers contain flameretardants and if so which. If flameretardants are used are they removed during the recycling process?	We don't have information on flame-retardant in laundry dryers. But the ecoreport tool does not have such a level of accuracy. As for manufacturing/ sorting/recycling, facilities should be equipped to fulfil the legal requirements of the RoHS and WEEE directives. A comment on flame-retardant in laundry dryers has been added.
31/10/2008 Natuur en Milieu	Chapter 3, p.28 To prevent condensation of moisture on user's hands a longer cooling down time could be used.	Ok.
31/10/2008 Danish Energy Agency	Page 29: In the existing energy labelling scheme for tumble dryers the energy classification is, as it also appears from figure 6, dependent on the dryer technology (venting or condensing). However a revised energy labelling scheme and future minimum energy efficiency requirements should preferably be independent of the dryer technology.	This will be addressed in task 8.
16/12/2008 Jamie Hothersall (Crosslee)	About modulating gas dryers: the report refers to American gas dryers which are completely different appliances to the European gas dryer. The document refers to a heat input of 11.7kW (40,000Btu) which compares to our typical European gas dryer at 3kW rating. I am not at all surprised that such a large heat input burner would benefit from modulation – the more efficient route would be for the drying time to be extended and a lower heat input burner to be used (ie exactly what we do with the current gas dryer design in Europe). Clearly a rapid drying time is the essential feature in the US. Also, the dryer itself has a maximum capacity of 15lb (6.8kg) and yet it has a drum which is considerable larger than that of a European 7kg machine.	Added in the report

VII Task 7: Improvement potential

VII.1 Objectives

Task 7 consists in assessing the costs and environmental benefits of the improvement options identified in Task 6. The main goals of this task are the following:

- Quantify the influence of the improvement options on environmental impacts and benchmark these options,
- Establish their Life Cycle Costs (LCC) for the consumer,
- Identify the design options using the Best Available Technology (BAT) and with the least life cycle cost (LLCC), crossing LCC curve and environmental impact curves.

Key improvement options have been identified on the basis of current technology development and research as described in Task 6. These improvement options are detailed in the following sub-sections, listing their respective environmental improvement potential and associated costs when implemented in the base cases.

VII.2 Improvement options

Potential design options that could be applicable to the base cases have already been presented in Task 6. According to the analysis performed in Task 6, the table below lists the improvement options that will be studied in task 7 and specifies to which base case it is applicable (only one or both technology).

Table 106: List of the individual improvement options

Design option	Condenser dryers	Vented dryers
Heat pump	x	x
Optimized process and system design	x	x
Improved motor concept (incl. control)	x	x
Heat recovery motor	x	x
Improved insulation	x	x
Combined drying programs	x	x
Improved sensor and control systems - load control	x	x
Improved sensor and control systems - intelligent load control	x	x
Two motors	x	x
Improved sensor and control systems - Humidity control	x	x
External Heat dryers	x	x
Gas dryers		x
Exhaust air heat recovery		x
Low heat long duration option		x
Mix airflow system		x

Among these different options, the following ones will not be studied in this task for the reasons specified below:

- Two motors: no data available on energy savings and costs,
- Low heat long duration option: no data available on energy savings and costs (actually energy savings cannot be assessed because of different ambient conditions and unknown effect on textiles),
- External heat dryers: no data available on energy savings,
- Improved sensor and control systems – humidity control, the base cases studied already include a humidity control, therefore this option will not be studied again as a potential improvement.

For each of the improvement options selected, the modifications implied by their implementation in the base case are quantified by the change in energy consumption and bill of material (when relevant and available). The improvement potential of a particular improvement option or a combination of improvement options is then evaluated using the EcoReport tool. It is necessary to note that the saving potentials given in task 6 were calculated with the energy consumption of the Base Case used as the reference.

The data provided are prices for consumers. They come mainly from industrial sources and were cross-referenced with actual market prices. A cost-engineering analysis would

be a valuable addition to the study. However, this was not possible at this stage. The issue being not as much the technical requirements (see Task 4) as the open communication of actual costs for components, additional materials, changes required in the production lines, profit margins, etc. (especially for heat pump dryers). Moreover, for example it is not meaningful to compare the prices with other heat pump systems as the technical requirements are not the same, thus we opted not to convey such values. The range of prices was significant for some options mainly because of the differences between manufacturers, that is why we have decided to consider average values.

Moreover, in this task, it should be noted that only current cost evaluations are taken into account. In the future, costs might decrease when market penetration (=produced quantities) increases and learning effects apply.

Payback time assumptions

The cost effectiveness of an improvement option can first be expressed in terms payback time in years, defined as the following ratio:

$$\frac{\text{Cost increase with reference to the base case}}{\text{Annual energy consumption difference in kWh * energy tariff}}$$

The main assumptions used for the payback time calculations are summarised in the following table:

Table 107: Assumptions for payback time calculations

	Standard Base Case Air vented tumble dryers	Standard Base Case Air condenser tumble dryers
Energy consumption (kWh/cycle)	3.36	3.6
Product lifetime	13	
Annual cycle number (cycle/year)	88	
Loading (weight of laundry; kg)	6 kg	
Electricity tariff (Euros / kWh)	0.17	
Gas tariff (Euros / kWh)	0.047	

	Real life Base Case Air vented tumble dryers	Real life Base Case Air condenser tumble dryers
Energy consumption (kWh/cycle)	2.01	2.15
Product lifetime	13	
Annual cycle number (cycle/year)	155	
Loading (weight of laundry; kg)	3.4 kg	
Electricity tariff (Euros / kWh)	0.17	
Gas tariff (Euros / kWh)	0.047	

VII.2.1 Common improvement options for both base cases.

Four improvement options have been identified for both dryer technologies. The description of their improvement potential is observed in this paragraph but the comparative analysis for each technology is added in paragraph VII.2.3 and VII.2.2 where comparisons between all options applicable to each base case are carried out.

Table 108: Energy savings potentials for the options applicable to both base cases

Design option	Energy saving potential (condensed / vented)	Additional costs for consumers (in euros)	Payback time (in years) (condensed / vented)
Improved insulation	4% -3%	55	26.26 - 40.85
Combined drying programs*	5% - 5%	15	5.18 – 5.04
Improved sensor and control systems – load control*	8% - 9%	30	5.99 – 5.87
Improved sensor and control systems - intelligent load control*	4% - 5%	50	18.98 – 19.58

*These three options could lead to energy savings only in the case of a use with partial load (no savings would occur if the dryer was used to its full capacity). As a consequence for these alternatives, the improvement potential is evaluated with the real life base case as a reference.

Improved insulation

Environmental Impact

The optimization of process and design could lead to 10-50 Wh/kg load of energy savings, which leads to global savings of 1-8% on the overall product lifetime. The energy saving potential largely depends on the drying technology. Thus, in order to compare the different improvement options, a value of 24 Wh/kg load for energy savings is considered for the air condensed dryer, which represents about 4% of energy savings.

A value of 19 Wh/kg load for energy savings is considered for the air vented dryer, which means about 3% of energy savings.

For the environmental impact assessment, no modification of the BOM was considered. Indeed, since an arithmetic average was calculated for the base case, it would be significant to take into account material variations of less than 10% as would be the case for this option.

The Ecoreport results are presented in Annexe T. A maximum global improvement on the overall life cycle impacts of 4% is observed. Considering the BOM definition, this improvement is too small to be significant.

Please note that in the context of the combination of heat pump condenser dryer and improved insulation, the potential energy savings due to insulation have been considered reduced to 14 Wh/kg load.

Cost

The average costs associated with the implementation of an improved insulation is 55 Euros; the payback time is thus 26 years for the condenser and 41 years for the air vented dryer.

Technical aspects

A technical constraint can be that the space available inside the dryer is limited due to standardized case dimensions.

Combined drying programme

This improvement option could lead to savings only in a use scenario with partial load. Thus, the saving potential is evaluated with the real life base case as a reference.

Environmental Impact

The availability of combined drying programme (programme allowing the drying of different clothe types in one programme) could lead to 19-47.5 Wh/kg load of energy savings, it leads to a global saving of [3-7%] for the overall product lifetime. In order to compare the different improvement options, a value of 33 Wh/kg load for energy savings is considered, it means about 5% of energy saving for condenser dryer (CD) and about 5% for air vented dryers (AV).

The savings that can be realised thanks to the use of combined drying programme largely depend on the consumer behaviour. Indeed, the consumer is the only responsible for the programme choice.

For the environmental impact assessment, no modification of the BOM was considered since none is necessary; this option only requires a software modification.

The Ecoreport results are presented in Annexe T. A maximum global improvement of the overall lifetime impacts of 4% is observed. Considering the accuracy of the BOM definition, this improvement is too small to be considered significant.

Cost

The implementation of a combined drying programme adds 15 Euros to the standard base case cost with a payback time of 5 year.

Technical aspects

This option is a possible upgrade path even for existing dryers. It will allow a better uniformity of drying considering the load is gathering clothes of the same type.

Sensor improvement – Load control

Environmental Impact

This improvement option consists on the implementation of a light or a sound signal that would indicate to the consumer when the drying machine is over-loaded or under-loaded, on the contrary of next option (intelligent load control) which would automatically adapt the drying program to the load of the machine.

This improvement option could lead to savings only in a use scenario with partial load. So, the saving potential is evaluated with the real life base case as a reference.

The addition of a load control sensor could lead to 19-95 Wh/kg load of energy savings. In order to compare the different improvement options, a value of 57Wh/kg load for energy savings is considered, it means about 8(CD)-9(AV)% of energy saving for the both technologies².

For the environmental impact assessment, no modification of the BOM was considered. It was estimated that the impact on the material balance could be neglected.

The Ecoreport results are presented in Annexe T. Concerning waste and consumption indicator, a maximum global improvement of the overall lifetime impacts of 8% is observed. Concerning the air pollution, an improvement of about 8% relating to global warming is observed. It is interesting to confirm that energy consumption and global warming are directly linked together.

Cost

The product cost increase associated to the sensor improvement (Load control) is 30 Euros and corresponds to a payback time of 6 years.

Sensor improvement – Intelligent load control*Environmental Impact*

This improvement option could lead to savings only in a use scenario with partial load. The saving potential is thus evaluated with the real life base case as a reference.

Adding an intelligent load control sensor could lead to 4.75-47.5 Wh/kg load of energy savings. In order to compare the different improvement options, a value of 28.5 Wh/kg load for energy savings is considered, it means about 4(CD)-5(AV)% of energy savings for the both technologies².

For the environmental impact assessment, no modification of the BOM was considered. Indeed, accounting for the small quantity of electronic components added to control the loading would not be relevant since the base case BOM is an average BOM.

The Ecoreport results are presented in Annexe T. Concerning waste and consumption indicator, a maximum global improvement of the overall lifetime impacts of 4% is observed. Concerning the air pollution, an improvement of about 4% relating to global warming is observed.

Cost

The additional cost of a sensor improvement (intelligent control) is 50 Euros, with a payback time of 19 years.

VII.2.2 Improvement options for Air vented dryers**Table 109: Improvement options for air vented dryer (Loading considered=6kg)**

Option	Design option	TEC savings (%) ¹⁴⁰	Energy Consumption (in kWh/cycle)	Additional costs for consumers (in euros)	Payback time (in years)
1	Heat pump technology for vented dryers	24%	2.5	250	19.43
2	Gas dryers		Elec 0.37 Gas: 3.65 kWh	350	11.79
3	Exhaust air heat recovery	8%	3.08	100	23.87
4	Optimized process and system design	7 %	3.10	75	19.28
5	Improved motor concept (incl. control)	4%	3.22	20	9.55
6	Heat recovery motor	2%	3,30	10	11.14
7*	Improved insulation	3%	3,27	55	40.85

* Applicable for both technologies and detailed in paragraph 2.2

¹⁴⁰ compared to base case (3.36/kwh.cycle)

Table 110: Improvement options for air vented dryer (Loading considered = 3.4 kg)

Option	Design option	TEC savings (%) ¹⁴¹	Energy Consumption (in kWh/cycle)	Average additional costs for consumers (in euros)	Payback time (in years)
8	Mix airflow system	4%	1.93	35	17.13
9*	Combined drying programs	5 %	1.90	15	5.04
10*	Improved sensor and control systems - Load control (acoustic/visual signal)	9 %	1.82	30	5.87
11*	Improved sensor and control systems – Intelligent load control	5 %	1.91	50	19.58

Heat pump technology for vented dryers (Option 1)

Environmental Impact

The use of a heat pump condenser dryer allows reducing the energy consumption of 24% in average.

Considering the fact that the addition of a heat pump leads to change in the dryer design and to material addition or deletion, it would be relevant to consider a specific average BOM. Nevertheless no data were collected because, according to the manufacturers, there is no data available regarding the BOM on Heat Pump vented dryers because none of them has developed such appliance at this stage.

So, the Ecoreport results are not as accurate as for the other options. Therefore, the conclusion relating to Heat Pump air vented dryer are to be taken with caution considering the lack of updated data for the BOM.

Cost

The product cost increase associated to a heat pump is 250 Euros and corresponds to a payback time of 19 years.

Gas dryers (Option 2)

Environmental Impact

The use of a gas dryer allows reducing the energy consumption of 42% in average and the electricity consumption of 81% in average.

Considering the fact that the drying technology and the security requirements are different, some significant changes in the design are to be taken into account. Consequently, one specific average BOM was collected from the manufacturer. The change in composition are presented in the following table

¹⁴¹ compared to base case (2.01 /kwh.cycle)

Table 111: Ecoreport BOM in terms of relative increase or decrease of materials with reference to the condenser dryer base case

Life Cycle phases -->		PRODUCTION		
Resources Use and Emissions		Material	Manuf.	Total
Materials	unit			
Bulk Plastics	g			53%
TecPlastics	g			-53%
Ferro	g			23%
Non-ferro	g			49%
Coating	g			0%
Electronics	g			-10%
Misc.	g			-11%
Total weight	g			18%

Regarding the significant difference in BOMs and in energy consumption type, it is interesting to analyse the impact repartition between the different life cycle phases. It can be observed on Figure 163 that the production phase has a higher relative impact than for the base case especially regarding water pollution. Concerning air pollution, use phase is the most impacting phase in term of greenhouse effect, air acidification and VOC emissions; whereas production phase is the most impacting phase in term of PAH emissions, Heavy metal emissions and POP emissions. It can be mostly explained by an important increase of the ferrous and non ferrous metal content combined with the fact that the energy used is a primary energy.

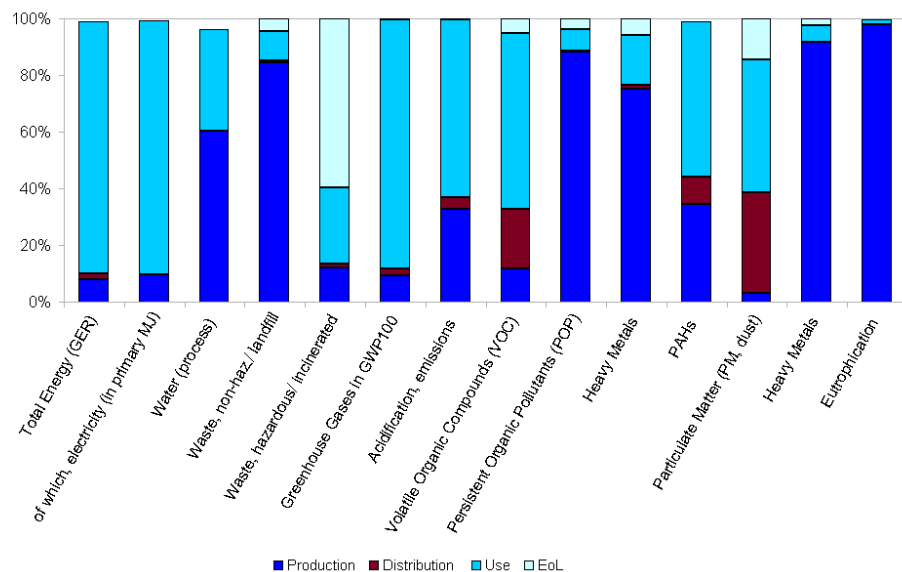

Figure 163: Impact repartition during the whole life cycle of gas dryer

The Ecoreport results are presented in terms of increase or decrease of the impacts with reference to the condenser dryer base case. It is to highlight that an impact decrease of up to 80% is observed for 2 indicators (Electricity and water consumptions). Globally, the gas dryer has a less important impact relating to 14 indicators and a worth impact relating to 1 indicators (water eutrophication) due to the use of an higher quantity of stainless steel.

Generally, it should be noted that environmental performance strongly depends on local energy production.

Table 112: Ecoreport results with reference to the air vented dryer base case.

Impact	Unit	Value
Other Resources & Waste		
Total Energy (GER)	MJ	56%
of which, electricity (in primary MJ)	MJ	13%
Water (process)	ltr	19%
Water (cooling)	ltr	12%
Waste, non-haz./ landfill	g	64%
Waste, hazardous/ incinerated	g	34%
Emissions (Air)		
Greenhouse Gases in GWP100	kg CO2 eq.	68%
Acidification, emissions	g SO2 eq.	22%
Volatile Organic Compounds (VOC)	g	99%
Persistent Organic Pollutants (POP)	ng i-Teq	73%
Heavy Metals	mg Ni eq.	70%
PAHs	mg Ni eq.	65%
Particulate Matter (PM, dust)	g	97%
Emissions (Water)		
Heavy Metals	mg Hg/20	90%
Eutrophication	g PO4	125%

Cost

The additional average cost of gas dryer is 350 Euros. The calculated payback time (considering electricity saving and additional gas expenses) is 12 years.

Exhaust air heat recovery (Option 3)*Environmental Impact*

The recuperation of the exhaust air allows preheating the incoming air with exhaust heat. This recovery could lead to 47.5 Wh/kg load of energy savings, it leads to a global saving of 8% for the overall product lifetime.

It is to notify that a heat exchanger and a pump have to be added, in order to reach this performance. Regarding the modification of the BOM for this option, we assume that some additional materials are necessary for this option but it would not significantly affect the global results of the BOM, according to manufacturers. Therefore, no modification of the BOM was considered for this option.

The Ecoreport results are presented in Annexe T. A global improvement of the overall lifetime impacts of 8% is observed.

Cost

The additional cost of exhaust air heat recovery system is 100 Euros, with a payback time of 24 years.

Optimized process and system design (Option 4)

Environmental Impact

The optimization of process and design could lead to 43 Wh/kg load of energy savings, it leads to a global saving of 7% for the overall product lifetime (Same value as already given for air condenser).

For the environmental impact assessment, no modification of the BOM was considered. Indeed, an arithmetic average was calculated for the base case, consequently the accuracy of the model is not sufficient to take into account material variation of less than 10%.

The Ecoreport results are presented in Annexe T. A global improvement of the overall lifetime impacts of 8% is observed.

Cost

The average cost associated to the implementation of an optimized process and system design is 75 Euros and the payback time is 19 year.

Improved motor concept (incl. control) (Option 5)

As for condenser dryer, improved motor concept entails a general optimisation of the motor concept including an optimisation of the control system.

Environmental impact

The improvement of the motor concept leads to 4% of energy savings along the product.

For the environmental impact assessment, considering the fact that the base case is defined as an arithmetic average, it was assumed that a change in the motor concept will only lead to an increase of 10% of the electronic compounds quantity. Therefore the BOM was not modified.

The Ecoreport results are presented in Annexe T. A global improvement of the overall lifetime impacts of [2-4]% is observed. Considering the accuracy of the BOM definition, this improvement is too small to be considered as significant.

Cost

The implementation of an improved motor concept adds 20 Euros to the standard base case cost with a payback time of 10 years.

Heat recovery motor (Option 6)

As relating to condenser dryer, the introduction of a heat recovery motor is only suitable for high-loss motors

Environmental Impact

The installation of a motor with heat recovery system leads to 9.5 Wh/kg load of energy savings, it leads to a global saving of 2% for the overall product lifetime.

For the environmental impact assessment, no modification of the BOM was considered (different routing of air tubes and fins on the motor neglected). Indeed, an arithmetic average was calculated for the base case, consequently the accuracy of the model is not sufficient to take into account material variation of less than 10%.

The Ecoreport results are presented in Annexe T. A global improvement of the overall lifetime impacts of [1-2]% is observed. Considering the accuracy of the BOM definition, this improvement is too small to be considered as doubtlessly significant.

Cost

The additional cost of heat recovery motor is 10 Euros, with a payback time of 11 years.

Mix airflow system (Option 8)

This option leads to energy saving only in the case of a use with partial load. As a consequence the potential energy savings and environmental impact improvements will be evaluated with the real life base case as a reference.

Environmental Impact

A partial recirculation of the exhaust air could lead to 24 Wh/kg load of energy savings. It conduces to a global saving of 5% for the overall product lifetime.

For the environmental impact assessment, no modification of the BOM was considered (the increase of air tubes amount was neglected).

The Ecoreport results are presented in Annexe T. Considering the fact that only the energy consumption changed, the most significant improvements are observed relating to energy and electricity consumption and relating to greenhouse gases emissions.

Cost

The additional cost of mix airflow system is 35 Euros, with a payback time of 17 years.

Technical aspects

The main technical constraint is that the space available inside dryers is limited due to standardized case dimensions. The problems of too high humidity in the exhaust duct with condensation are a also restricting problem.

Comparison of the improvement options for air vented dryers and conclusions

The change in 15 environmental impact indicators due to the implementation of each individual option can be expressed in terms of percentage with reference to the base case (100%). All the following Figure s will allow identifying the best option considering each of the impact indicators.

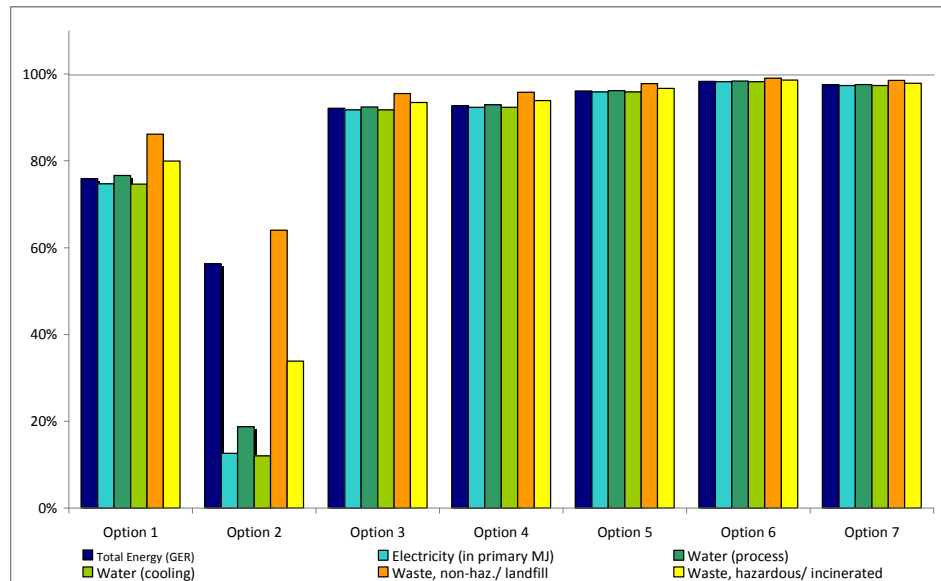

Figure 164: Comparison of the different options with the standard air vented dryer base case as reference (resources & wastes)

*Option 1 = Heat pump air vented dryer, Option 2 = Gas dryer, Option 3 = Exhaust air heat recovery, Option 4 = Optimized process and system design, Option 5 = Improved motor concept, Option 6 = Heat recovery motor, Option 7 = Improved insulation

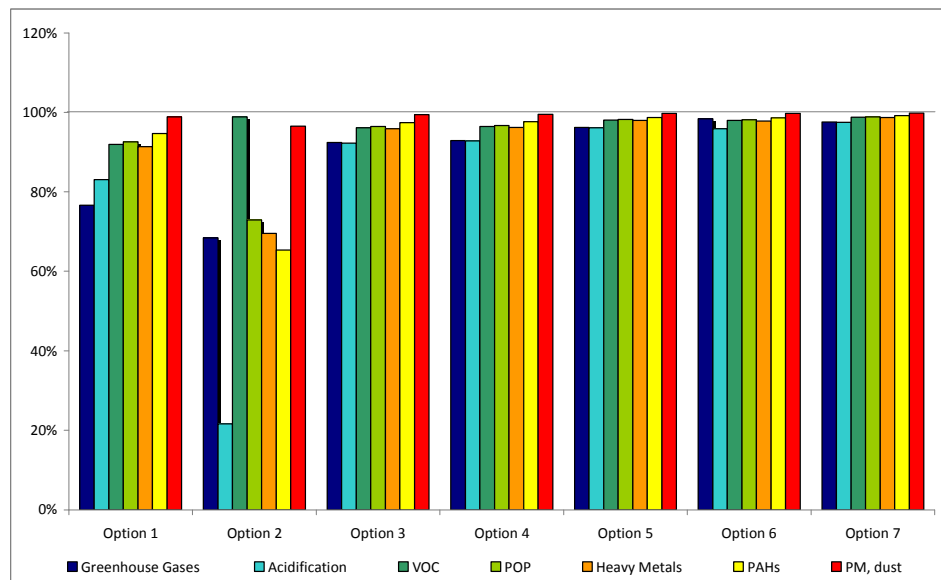

Figure 165: Comparison of the different options with the standard air vented dryer base case as reference (emissions to air)

*Option 1 = Heat pump air vented dryer, Option 2 = Gas dryer, Option 3 = Exhaust air heat recovery, Option 4 = Optimized process and system design, Option 5 = Improved motor concept, Option 6 = Heat recovery motor, Option 7 = Improved insulation

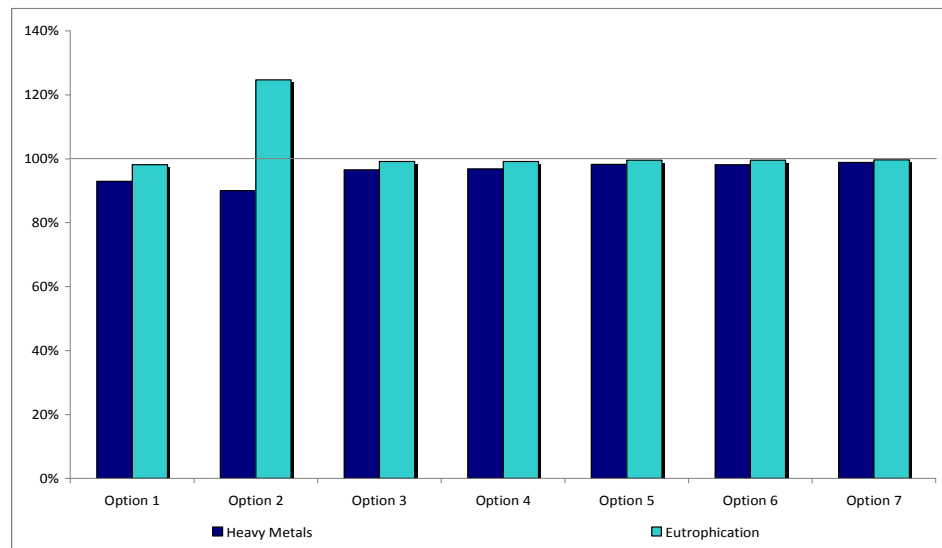

Figure 166: Comparison of the different options with the standard air vented dryer base case as reference (emissions to water)

*Option 1 = Heat pump air vented dryer, Option 2 = Gas dryer, Option 3 = Exhaust air heat recovery, Option 4 = Optimized process and system design, Option 5 = Improved motor concept, Option 6 = Heat recovery motor, Option 7 = Improved insulation

Table 113: Ranking of the 3 best performing improvement options of the base case air vented dryer for each impact indicator

Indicator	Best Option for this indicator*	2nd best Option for this indicator*	35d best Option for this indicator*
Total Energy (GER)	Option N°2	Option N°1	Option N°3
of which, electricity (in primary MJ)	Option N°2	Option N°1	Option N°3
Water (process)	Option N°2	Option N°1	Option N°3
Water (cooling)	Option N°2	Option N°1	Option N°3
Waste, non-haz./landfill	Option N°2	Option N°1	Option N°3
Waste, hazardous/incinerated	Option N°2	Option N°1	Option N°3
Greenhouse Gases in GWP100	Option N°2	Option N°1	Option N°3
Acidification emissions	Option N°2	Option N°1	Option N°3
Volatile Organic Compounds (VOC)	Option N°2	Option N°1	Option N°3
Persistent Organic Pollutants (POP)	Option N°2	Option N°1	Option N°3
Heavy Metals (air)	Option N°2	Option N°1	Option N°3
PAHs	Option N°2	Option N°1	Option N°3
Particulate Matter (PM, dust)	Option N°2	Option N°1	Option N°3
Heavy Metals (water)	Option N°2	Option N°1	Option N°3
Eutrophication	Option N°1	Option n°3	Option n°4

Comparison conclusions

This table does not include improvement options applicable to partial load. This ranking is only valid for improvement options applicable to full load base case.

This ranking is confirming paragraph 2.4.2 results. **The Option n°2(Gas dryer)** appears as the best option of the benchmark for most of the indicators (Energy and water consumption, air acidification...) with a clear impact reduction ; however it appears also as the worst option for the Eutrophication.

Option n°1 often appears in top 3, but you have to keep in mind that the BOM was not modified. So, the difference in product composition is not taken into account and a new calculation with complete data could probably lead to very different conclusions (for example, in term of PAHs emissions).

We can finally notice, that **Option n°3 (Exhaust air heat recovery)** appears in the top 3 for all the indicators. But, as for option n°1 you have to keep in mind that the BOM was not modified.

In order to complete this overview, the improvement option allowing the reduction of energy consumption in real life conditions (with partial load) will be presented on Figure 167, Figure 168 and Figure 169.

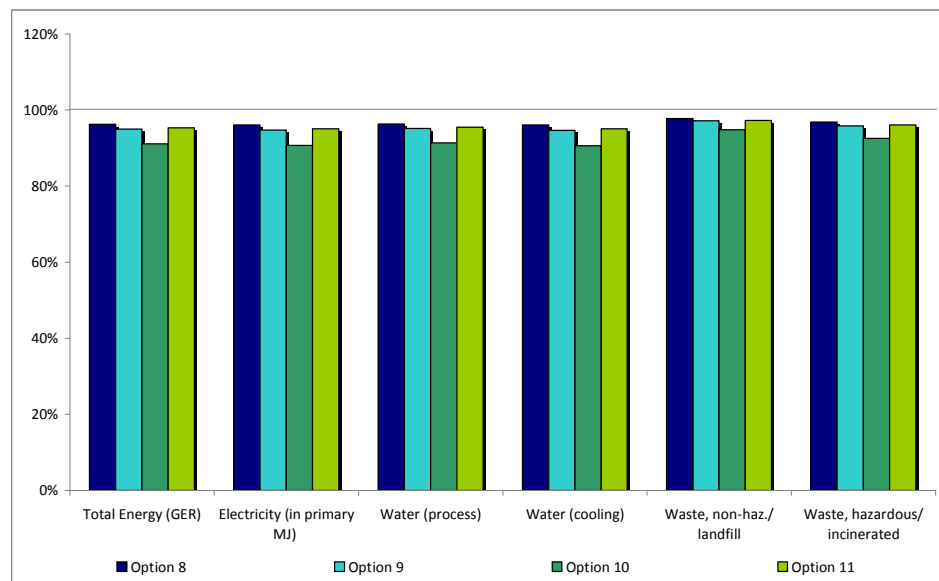

Figure 167: Comparison of the different options with the real life air vented dryer base case as reference (resources & wastes)

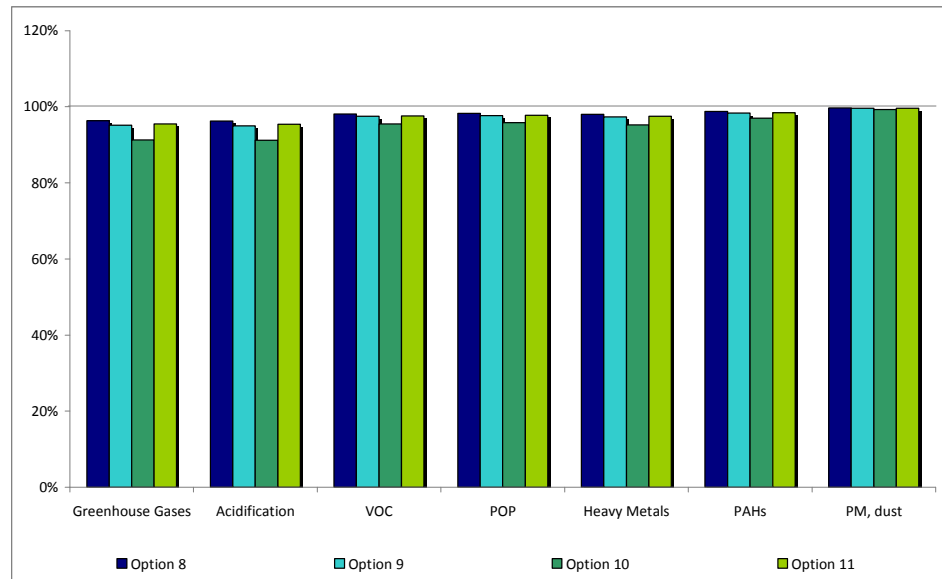

Figure 168: Comparison of the different options with the real life air vented dryer base case as reference (emission to air)

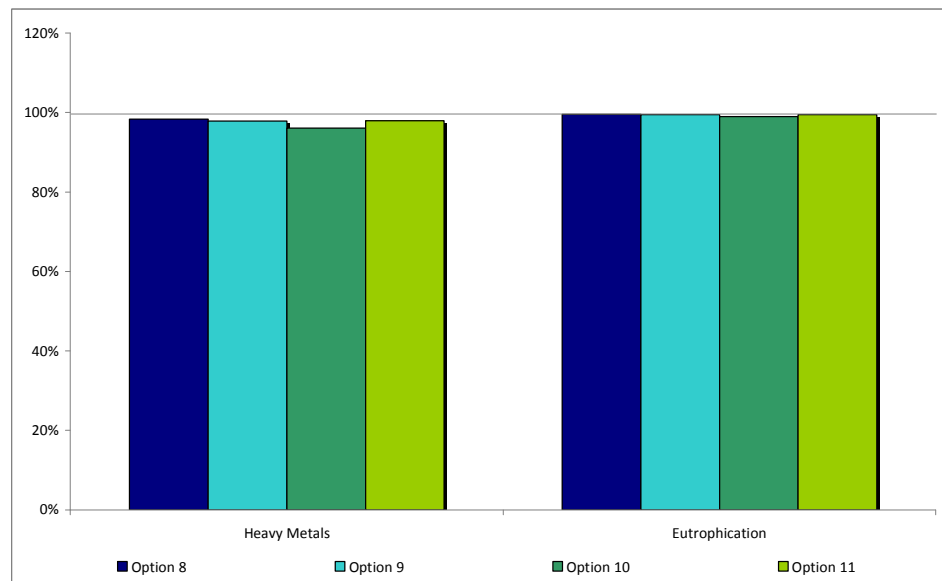

Figure 169: Comparison of the different options with the real life air vented dryer base case as reference (emission to air)

VII.2.3 Improvement options for Air condenser dryers

Four specific improvement options for condenser dryers were defined in task 6. All of these design options and their improvement potentials are presented in Annexe T. For each alternative, the environmental impact and LCC is re-evaluated.

Table 114: Improvement options for condenser dryers (Loading considered = 6kg)

N°	Design option	TEC savings (%) ¹⁴²	Energy Consumption (in kWh/cycle)	Additional costs for consumers (in euros)	Payback time (years)
1	Heat pump condenser dryers	39%	2	330	13.79
2	Optimized process and system design	7%	3.32	95	22.68
3	Improved motor concept (incl. control)	4%	3.46	25	11.94
4	Heat recovery motor	8%	3.54	20	22.28
5*	Improved insulation	7%	3.46	55	26.26

* Applicable for both technologies and detailed in paragraph 2.2

Table 115: Improvement options for condenser dryers only (Loading considered = 3.4 kg)

N°	Design option	TEC savings (%) ¹⁴³	Energy Consumption (in kWh/cycle)	Additional costs for consumers (in euros)	Payback time (years)
6*	Combined drying programs	5%	2.04	15	5.18
7*	Improved sensor and control systems - Load control (acoustic/visual signal)	8%	1.96	30	5.99
8*	Improved sensor and control systems – Intelligent load control	4%	2.05	50	18.98

Heat pump condenser dryers (Option 1)

Environmental Impact

The use of a heat pump condenser dryer allows reducing the energy consumption of 35% in average.

Considering the fact that the addition of a heat pump leads to change in the dryer design and to material addition or deletion, a specific average BOM was collected from the manufacturers (see Table 116)

¹⁴² compared to base case (3.6 kwh/cycle)
¹⁴³ compared to base case (2.15 kwh/cycle)

Table 116: Ecoreport BOM in terms of relative increase or decrease of materials with reference to the condenser dryer base case

Life Cycle phases -->		PRODUCTION		
Resources Use and Emissions		Material	Manuf.	Total
Materials	unit			
Bulk Plastics	g			11%
TecPlastics	g			47%
Ferro	g			38%
Non-ferro	g			130%
Coating	g			0%
Electronics	g			-46%
Misc.	g			95%
Total weight	g			31%

Regarding the significant difference in BOMs and in energy consumption, it is interesting to analyse the impact repartition between the different life cycle phases. It can be observed on

that the production phase has a higher relative impact than for the base case especially regarding air and water pollution. It can be mostly explained by an important increase of the ferrous and non ferrous metal content combined with the high electricity consumption reduction.

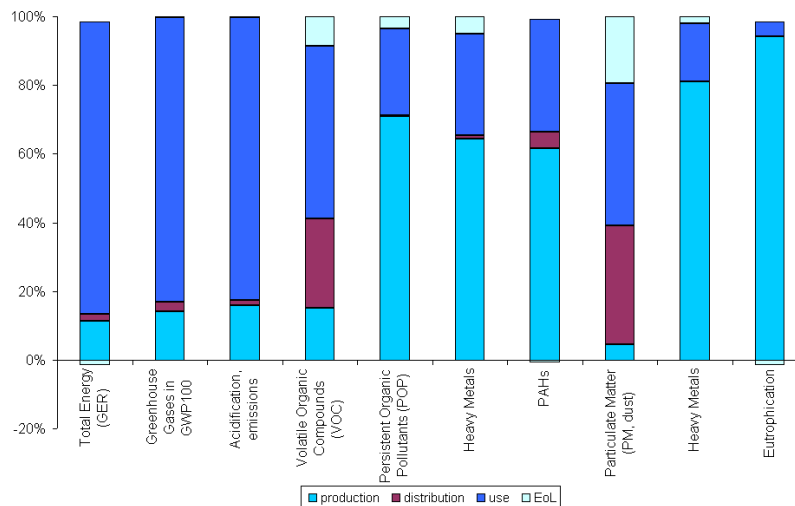

Figure 170: Impact repartition during the whole life cycle of a heat pump condenser dryer

The Ecoreport results are presented in terms of increase or decrease of the impacts with reference to the condenser dryer base case. It is to highlight that an impact decrease of 30% to 43% is observed for 6 indicators (mostly concerning energy consumptions, water consumption and global warming potential). But the impact of the heat pump tumble dryer is worth regarding 6 impact indicators. These observations can be explained by an important change in composition and especially by the increase in stainless steel contents.

Table 117: Ecoreport results with reference to the condenser dryer base case

Indicator	Unit	Values
Other Resources & Waste		
Total Energy (GER)	MJ	61%
of which, electricity (in primary MJ)	MJ	57%
Water (process)	ltr	69%
Water (cooling)	ltr	56%
Waste, non-haz./ landfill	g	99%
Waste, hazardous/ incinerated	g	74%
Emissions (Air)		
Greenhouse Gases in GWP100	kg CO2 eq.	64%
Ozone Depletion, emissions	mg R-11 eq.	
Acidification, emissions	g SO2 eq.	63%
Volatile Organic Compounds (VOC)	g	103%
Persistent Organic Pollutants (POP)	ng i-Teq	97%
Heavy Metals	mg Ni eq.	130%
PAHs	mg Ni eq.	173%
Particulate Matter (PM, dust)	g	166%
Emissions (Water)		
Heavy Metals	mg Hg/20	146%
Eutrophication	g PO4	179%

Cost

The average additional cost associated to the implementation of a heat pump compared to the base case is 330 Euros and its payback time is 14 years.

Constraint

Heat pump dryers include fluorinated Hydrocarbons as cooling agent (currently R 134a but R407c too). These substances have an high global warming potential (GWP), which can partly compensate the lower GWP through the lower electricity demand during the use phase. However recent investigations leaded by Öko-Institut show, that even if the whole amount of the cooling agent would be released into the environment, heat pump dryers still have a lower overall GWP compared to even B-class condenser dryers.

Table 118: Global warming potential for different type of refrigerant

Refrigerant	GWP/kg refrigerant
R134a	1.43 kg CO ₂ eq/kg R134a
R407c	1.77 kg CO ₂ eq/kg R407c

However, the use of refrigerants and their GWP is still an issue, which has to be kept in mind – effective take back and recycling schemes have to be developed to dispose as much of the cooling agent as possible. Furthermore, ecodesign requirements have to be elaborated with respect to the refrigerants' harm potential to human health and the environment.

Optimized process and system design (Option 2)

Environmental Impact

The optimization of process and design could lead to 47.5 Wh/kg load of energy savings, it leads to a global saving of 7% for the overall product lifetime.

For the environmental impact assessment, no modification of the BOM was observed. Indeed, an arithmetic average was calculated for the base case, consequently the accuracy of the model is not sufficient to take into account material variation of less than 10%.

The Ecoreport results are presented in Annexe T. A global improvement of the overall lifetime impacts of 8% is observed.

Cost

The additional cost of a optimized process and system design is 95 Euros, with a payback time of 23 years.

Improved motor concept (incl. control) (Option 3)

Improved motor concept entails a general optimisation of the motor concept including an optimisation of the control system. For example, motors as inverter-fed three phase permanent motors or permanent magnet DC motor can be used

Environmental impact

The improvement of the motor concept leads to 4% of energy savings along the product.

For the environmental impact assessment, considering the fact that the base case is defined as an arithmetic average, it was assumed that a change in the motor concept will only lead to an increase of 10% of the electronic compounds quantity. The Ecoreport results are presented in Annexe T. A global improvement of the overall lifetime impacts of [2-4]% is observed. Considering the accuracy of the BOM definition, this improvement is too small to be considered as significant.

Cost

The product cost increase associated to an improved motor concept (including control) is 25 Euros and correspond to payback time of 12 years.

Heat recovery motor (Option 4)

The introduction of a heat recovery motor is only suitable for high-loss motors

Environmental Impact

The installation of a motor with heat recovery system leads to 9.5 Wh/kg load of energy savings, it conduce to a global saving of 2% for the overall product lifetime.

For the environmental impact assessment, no modification of the BOM was observed. Indeed, an arithmetic average was calculated for the base case, consequently the accuracy of the model is not sufficient to take into account material variation of less than 10%.

The Ecoreport results are presented in Annexe T. A global improvement of the overall lifetime impacts of [1-2]% is observed. Considering the accuracy of the BOM definition, this improvement is too small to be considered as significant.

Cost

The implementation of a heat recovery motor adds 20 Euros to the standard base case cost with a payback time of 22 year.

Comparison of the improvement options for air condenser dryers and conclusions

The change in 15 environmental impact indicators due to the implementation of each individual option can be expressed in terms of percentage with reference to the standard base case (100%) for option 1 to 5 and with reference to the real life base case for option 6 to 8.

First of all, on 2 to 5, the improvement potential for each of the 15 indicators are presented for option 1 to 5, which are implemented in optimal conditions, it means with full load. Thanks to this comparison, the most interesting solution will be identified in Table 8.

Another comparison will be made for improvement options valid only for a use with a partial loading (option 6-8).

All the following Figure s will allow identifying the best option considering each of the impact indicators.

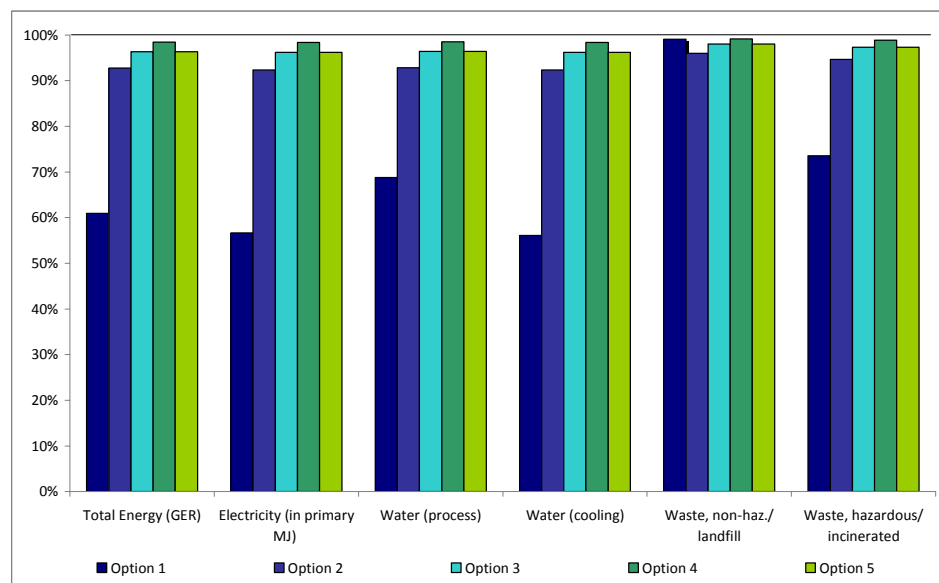

Figure 171: Comparison of the different options with the standard air condenser dryer base case as reference (resources & wastes)

*Option1 = Heat pump condenser dryer, Option 2 = Optimized process, Option 3 = Improved motor concept, Option 4 = Heat recovery motor, Option 5 = Improved insulation

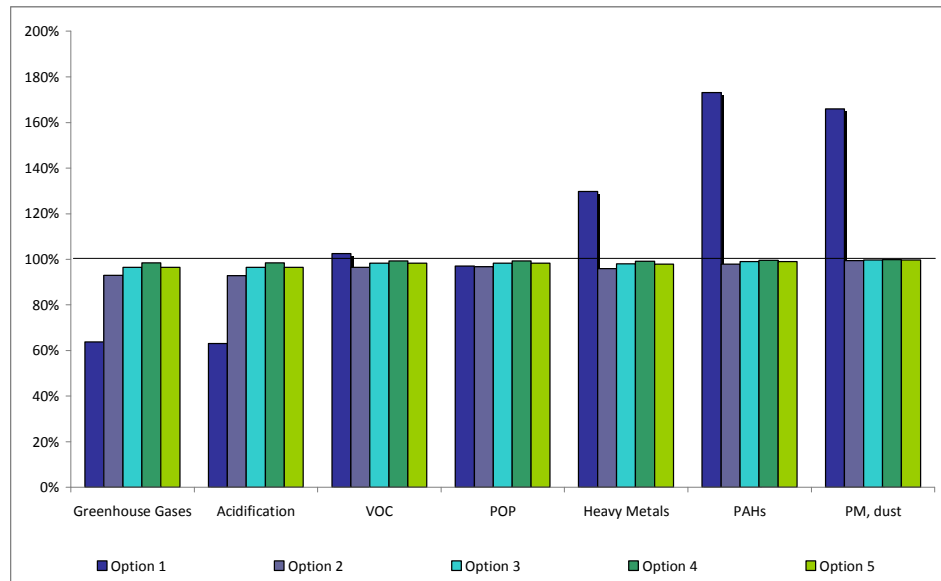

Figure 172: Comparison of the different options with the air standard air condenser dryer base case as reference (air emissions)

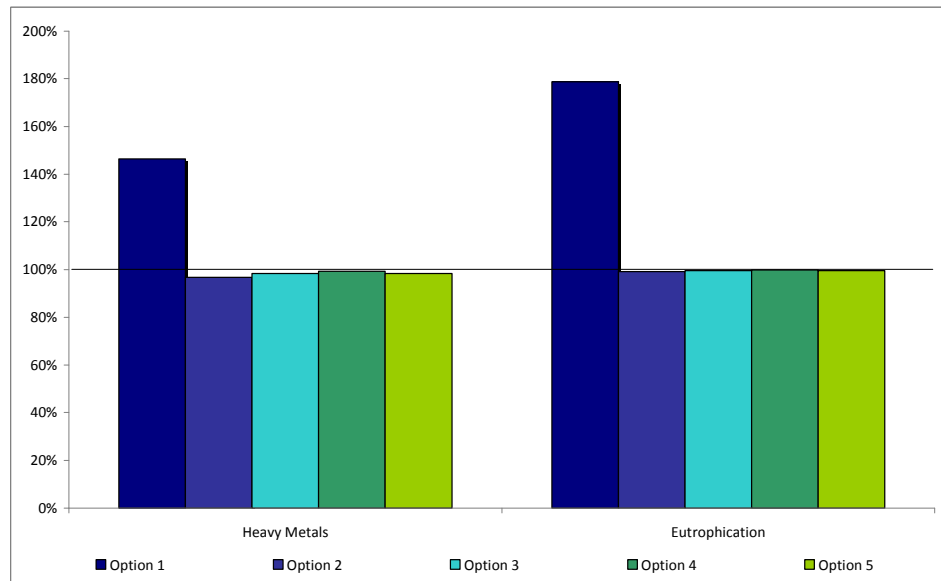

Figure 173: Comparison of the different options with the standard air condenser dryer base case as reference (water emissions)

Table 119: Ranking of the 3 best performing improvement options of the base case air condenser dryer for each impact indicator

Indicator	Best Option for this indicator	2nd best Option for this indicator	3rd best Option for this indicator
Total Energy (GER)	Option N°1	Option N°2	Option N°3-5
of which, electricity (in primary MJ)	Option N°1	Option N°2	Option N°3-5
Water (process)	Option N°1	Option N°2	Option N°3-5
Water (cooling)	Option N°1	Option N°2	Option N°3-5
Waste, non-haz./landfill	Option N°1	Option N°2	Option N°3-5
Waste, hazardous/incinerated	Option N°1	Option N°2	Option N°3-5
Greenhouse Gases in GWP100	Option N°1	Option N°2	Option N°3-5
Acidification emissions	Option N°2	Option N°3-5	Option N°4
Volatile Organic Compounds (VOC)	Option N°2	Option N°3-5	Option N°4
Persistent Organic Pollutants (POP)	Option N°2	Option N°3-5	Option N°4
Heavy Metals (air)	Option N°2	Option N°3-5	Option N°4
PAHs	Option N°2	Option N°3-5	Option N°4
Particulate Matter (PM, dust)	Option N°2	Option N°3-5	Option N°4
Heavy Metals (water)	Option N°2	Option N°3-5	Option N°4
Eutrophication	Option N°2		

Comparison conclusions

This table does not include improvement options applicable to partial load. This ranking is only valid for improvement options applicable to full load base case.

Confirming paragraph 2.3.1 results, Option N°1 (Heat pump) is the best option for energy and water consumption, wastes, GHG emissions, air acidification and VOC indicators. However this option appears as the worst one of the benchmark for water emissions, PAHs, Heavy metals, PM dust.

Options n°2 (Optimized process and system design) appears in the top 3 for all the indicators.

In order to complete this overview, the improvement option allowing the reduction of energy consumption in real life conditions (with partial load) will be presented on Figure 174, Figure 175 and Figure 176

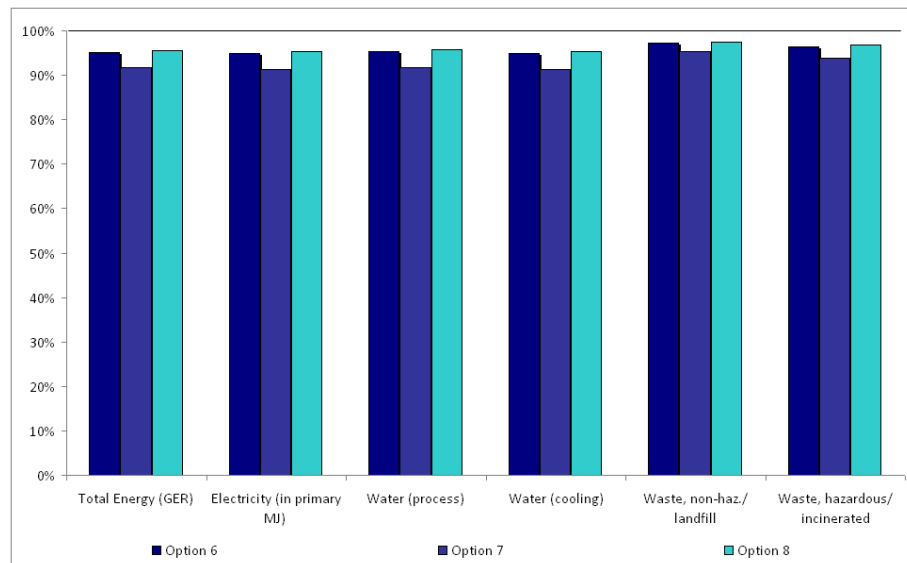

Figure 174: Comparison of the different options with real life air condenser dryer base case as reference (resources & wastes)

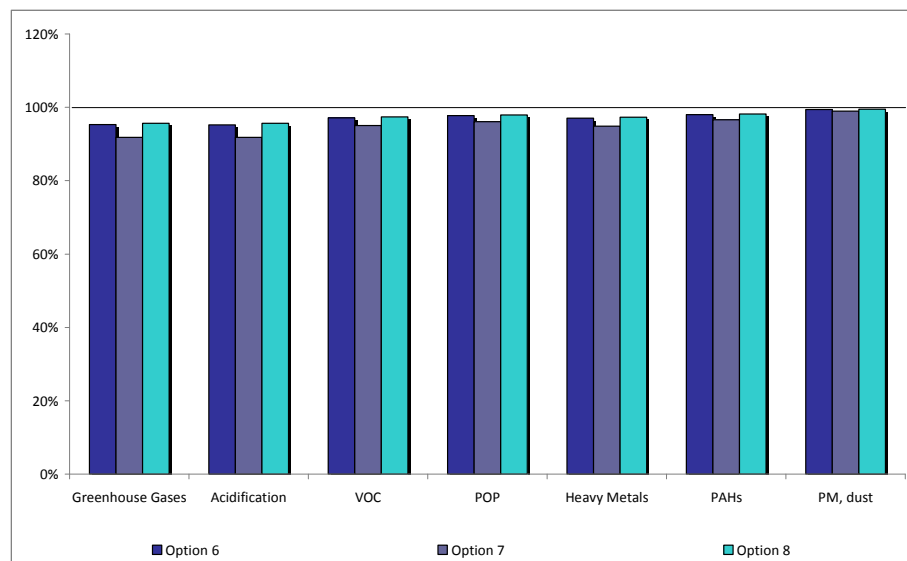

Figure 175: Comparison of the different options with the real life air condenser dryer base case as reference (air emissions)

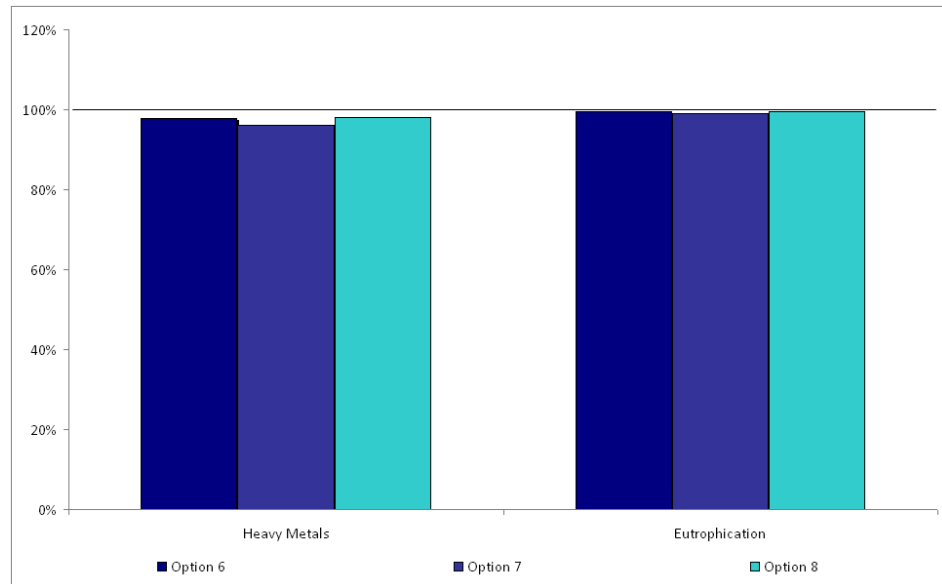

Figure 176: Comparison of the different options with the real life air condenser dryer base case as reference (water emissions)

VII.3 LLCC and BAT analyses

In this section improvement options are evaluated for their environmental and economic implications extending over the complete life cycle of the product.

The objective of this sub-task is to analyse improvement options using EcoReport and then prioritise them according to their life cycle costs (LCC) in order to identify the option with least environmental impacts and with least life cycle cost (LLCC). Different improvement options can be combined together if applicable to a specific base case or product range. Following subsections present such options (individual or combination of options) and their respective LCC.

Individual options have different effects: some allow important environmental improvement at high extra production costs; some are less expensive and deliver significant environmental improvement providing reduction in running costs.

On the basis of obtained results, following graphs show the environmental assessments for each base case with LCC in Euros on the left Y-axis and key environmental parameter (electricity costs, total energy consumption over lifetime including production phase, and Global Warming Potential) on the right Y-axis. It should be noted that the scales are different for each graph to give a better overview of the differences among the options.

The graphs provided in this section allow drawing conclusions only for each base case without taking into account the complete stock of products present on the EU market e.g. some of them may have high improvement potential but with limited quantities on the market and therefore limited potential energy gains.

Remark: The total environment impact of Eco-design measures, using Task 2 results and considering the stock Figure s shall be studied in task 8 “ Policy and scenario analysis” .

VII.3.1 Base case Air vented dryer

Individual improvement options

The Ecoreport analysis of the 11 individual improvement options applicable to the vented dryer base case is presented in the following table. Improvements options applicable to full load or only partial load are separated.

In the following table, individual options have been ranked by payback

Table 120: Summary of the cost and benefit effects of implementing individual improvement options for the base case vented dryers

N° Option	Design option	Technologies	Total Energy GER (MJ/per product)	GWP	Electricity cost Costs (Euros/lifetime)	LCC (Euros)	Payback (Year)	Cost increase (Euros)	TEC saving (%)	BOM modification
0	Vented Base Case - full load		42 809	1 929	474	906				
5	Improved motor concept (incl. control)	Vented Dryers	41 127	1 856	454	906	9.55	20	4%	no
6	Heat recovery motor	Vented Dryers	42 089	1 898	465	907	11.14	10	2%	no
2	Gas dryers	Vented Dryers	24 114	1 315	196	978	11.79	350		yes cf § 2.4. 2
4	Optimized process and system design	Vented Dryers	39 686	1 793	437	944	19.28	75	7%	no
1	Heat pump technology for vented dryers	Vented Dryers	32 479	1 478	353	1035	19.43	250	24%	no data
3	Exhaust air heat recovery	Vented Dryers	39 446	1 782	434	966	23.87	100	8%	no
7	Improved insulation	all technologies	41 728	1 882	461	948	40.85	55	3%	no
0	Vented Base Case - partial load		44 975	2 024	499	931				
9	Combined drying programs	all technologies	42 648	1 922	472	919	5.04	15	5%	no
10	Improved sensor and control systems - Load control (acoustic/ visual signal)	all technologies	40 955	1 848	452	914	5.87	30	9%	no
8	Mix airflow system	Vented Dryers	43 283	1 950	479	946	17.13	35	4%	no
11	Improved sensor and control systems – Intelligent load control	all technologies	42 859	1 931	474	956	19.58	50	5%	no

The environmental performance is plotted together with the LCC values. Three curves are presented in this paragraph using three indicators below:

- Electricity costs (during use phase) over the product life (Euros/product), this reflects the electricity use,
- Total energy consumption during the whole lifetime of vented dryer (GER in MJ/product), or
- Global Warming Potential (GWP in kg CO₂ eq./product)

Again, as the electricity costs represent a major share (51%) of the LCC of the standard base case (followed by the product purchase costs - 42%), LCC curve, electricity costs, GER and GWP curves are closely correlated.

This time, **two options do not follow this trend: Option n°1 (Heat pump) and Option N°2 (Gas dryers)**. For the same reason as explained in the previous paragraph (condenser dryers base case), the high cost increase of this both improvement options (respectively + 66% and + 92%) is not balanced by the energy saving realized all along the lifetime of the product. Consequently for these two options, values of electricity costs and GER are the lower ones of the benchmark, whereas LCC values are the higher ones. Moreover if the implementation of a gas dryer (Option n°2) does not reduce significantly the GWP, the Heat Pump improvement (Option n°1) allows a reduction of 23% of the indicator in comparison with the base case, increasing the LCC by 14%. **This option can therefore again be considered as the BAT.**

Remark: Please note again that if the increase cost implementing a heat pump for vented dryers was lowered from 250 Euros(assumption used in this task) to 121 Euros it would lead to an LCC equal to the base case (906 Euros). This would also be achieved in the case gas dryers reducing the cost increase from 350 Euros to 278 Euros. Specific sensitivity analysis regarding those points will be performed in Task 8.

Option 10 (Improved sensor and control systems - Load control (acoustic/visual signal)) leads to the LLCC (914 Euros) and improves significantly the 3 indicators reducing by around 9% the values in comparison with the base case.

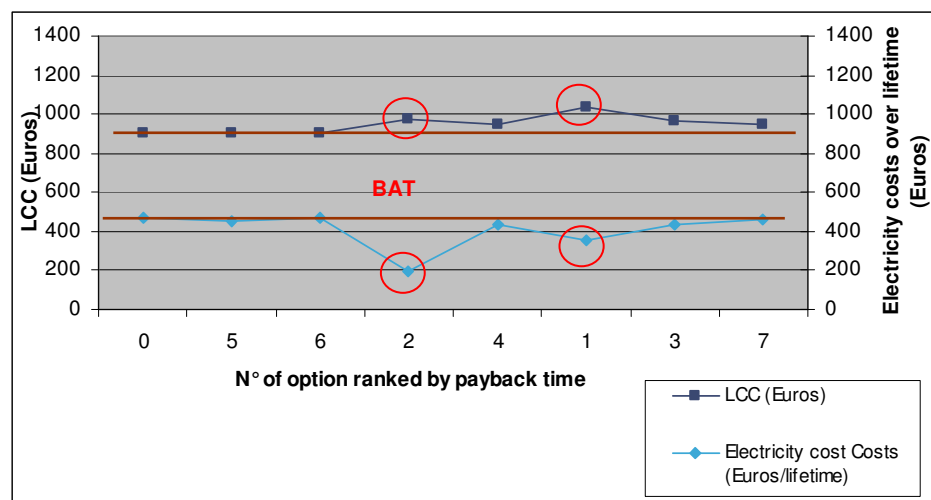

Figure 177 LCC Curve- Environmental performance expressed in total electricity costs for the full load vented base case

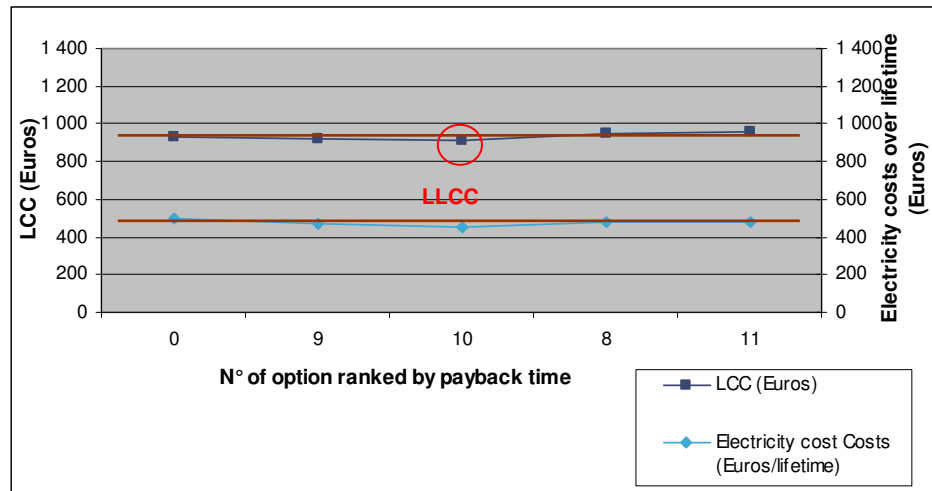

Figure 178 LCC Curve- Environmental performance expressed in total electricity costs for the partial load vented base case

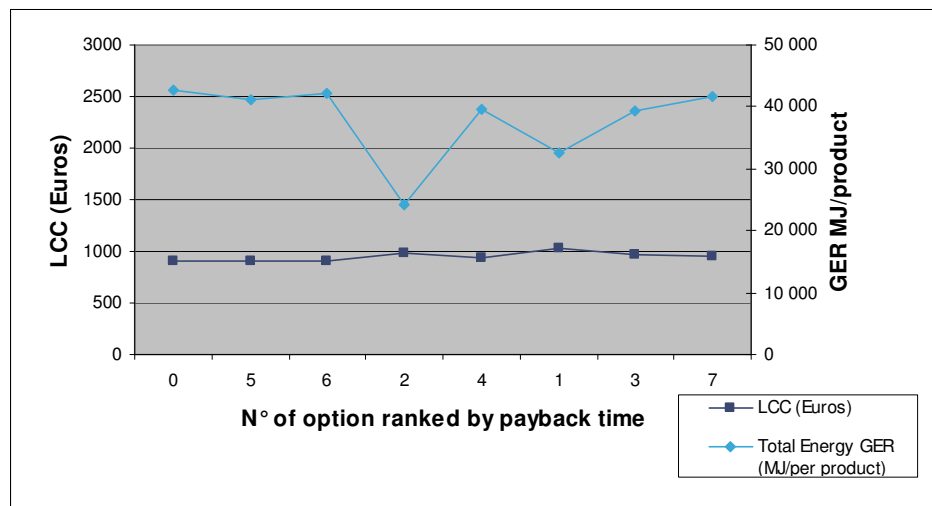

Figure 179 LCC Curve- Environmental performance expressed in total energy consumption for the full load vented base case

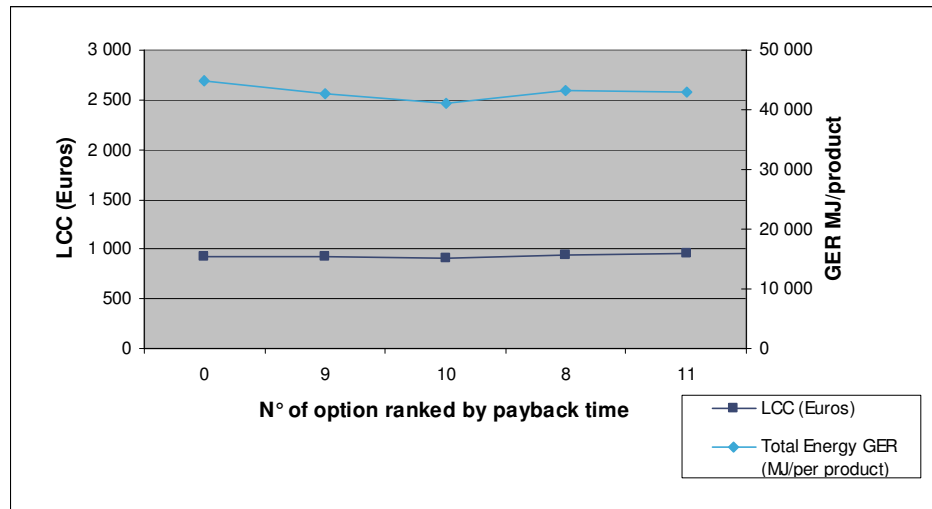

Figure 180 LCC Curve- Environmental performance expressed in total energy consumption for the partial load vented base case

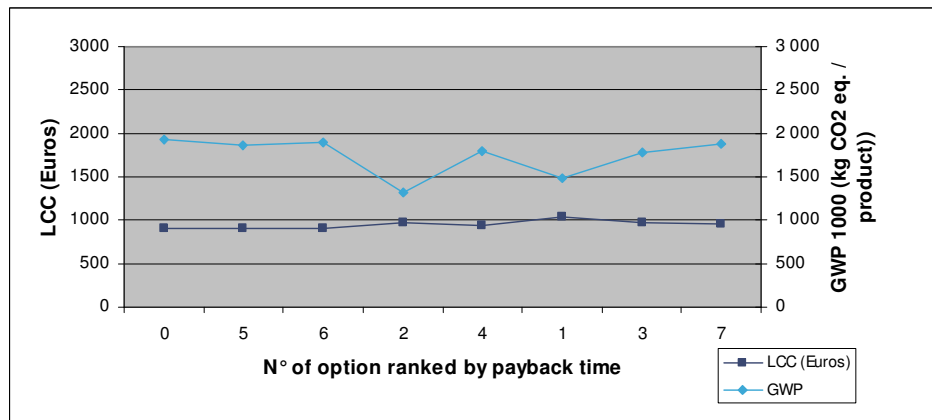

Figure 181: LCC Curve - Environmental performance expressed in GWP for the full load vented base case

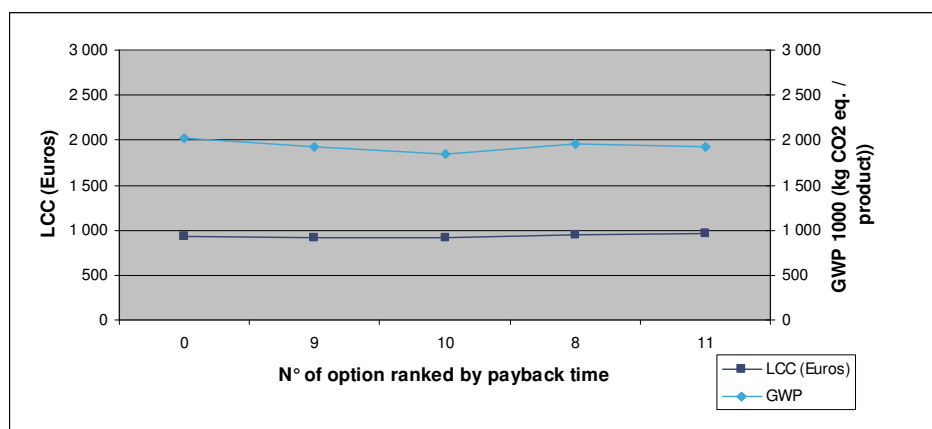

Figure 182: LCC Curve - Environmental performance expressed in GWP for the partial load vented base case

Effect of cumulative options for vented dryers

General hypothesis regarding cumulative options

The following analysis performed for combined options as presented previously in Task 6 are based on the following assumptions:

The combination of the improvement potential technologies are in general independent from each one, and therefore, the energy savings that can be obtained from the combination of the technologies should be derived most of the time from the addition of the independent savings of the appliances. Slight interactions can appear but do not have misleading influence on the overall result,

However when a reduced effect was supposed, the value of the cumulated savings has been estimated by the experts.

New BOM for combined options have not been considered even if some changes could appear in the material composition,

Only full load improvement options have been cumulated. Partial load are excluded from the scope of accumulation.

Moreover considering that, we do not dispose of a detailed BOM for the heat pump air vented dryer, the influence of BOM change is very high (see combined design option for condenser dryer).

We decided not to include heat pump air vented dryer in the combined design options.

Finally, the gas air vented dryers do not appear in our combination. Indeed, we do not have enough information of the influence of the improvement option on the gas consumptions and it is not relevant to allocate the energy savings only at the electricity level. Nevertheless, gas air vented dryers (individual option) are presented as a reference in the environmental impact analysis.

In the following table and graphics, cumulative options have been ranked by total LCC.

Table 121: Summary of the cost and benefit effects of implementing improvement options or air vented dryers –options combinations are ranked by total LCC

Combination	Consumption/cycle	Total Energy GER (MJ/per product)	GWP	Electricity Costs (Euros/lifetime)	LCC (Euros)	Payback (Year)	Cost increase (Euros)	TEC saving (%)
0	3.36	42 809	1 929	474	906			
5+6*	3.19		1 866	457	919	16.71	30	3%
7+5	3.08	39 446	1 782	434	941	17.90	75	8%
7+5+6	3.05	39 085	1 766	430	947	18.33	85	9%
5+3	2.93	37 644	1 704	413	965	18.65	120	12%
5+3+6	2.87	36 923	1 672	405	967	17.73	130	14%
7+3	2.93	37 644	1 704	413	1000	24.10	155	12%
7+3+5	2.79	35 962	1 630	394	1000	20.52	175	16%
7+3+5+6	2.76	35 602	1 614	390	1006	20.61	185	17%

*In the calculation of energy savings for the combination Option 5+6, a potential energy saving of 4.75Wh/kg was considered. Indeed in table 4 of the task 6, it was mentioned that a combination between improved motor concept and heat recovery motor has a reduced effect on the energy savings.

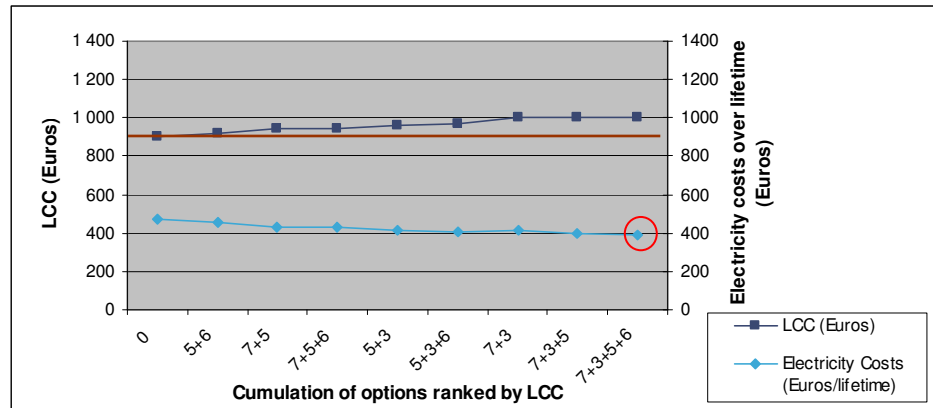

Figure 183: LCC Curve; environmental performance expressed in total electricity costs for the vented base case cumulating options

These combinations of options do not allow determining any combination leading to a LLCC. All combinations lead to an LCC superior to the one of the base case.

The combined options with the least energy consumption is once again the combination of the maximum of options (7 +3 + 5 +6) allowing reducing by 18% the energy savings in comparison with the base case; and leading to an LCC superior by 11% to the BC.

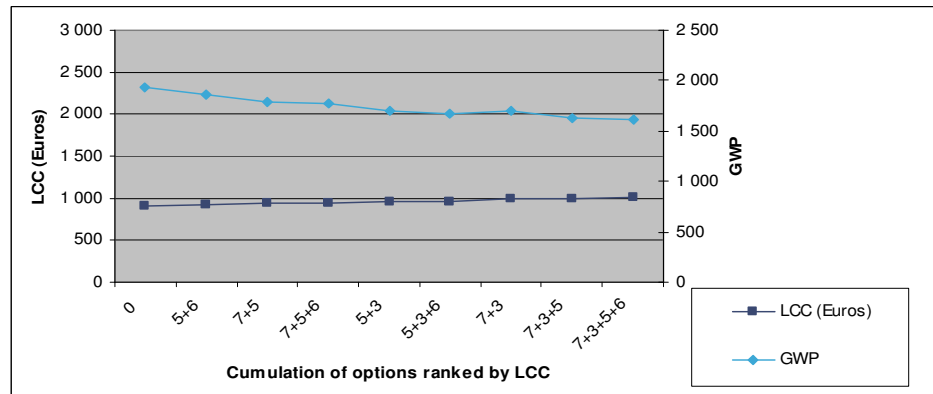

Figure 184: LCC Curve; environmental performance expressed in GWP for the vented base case cumulating options

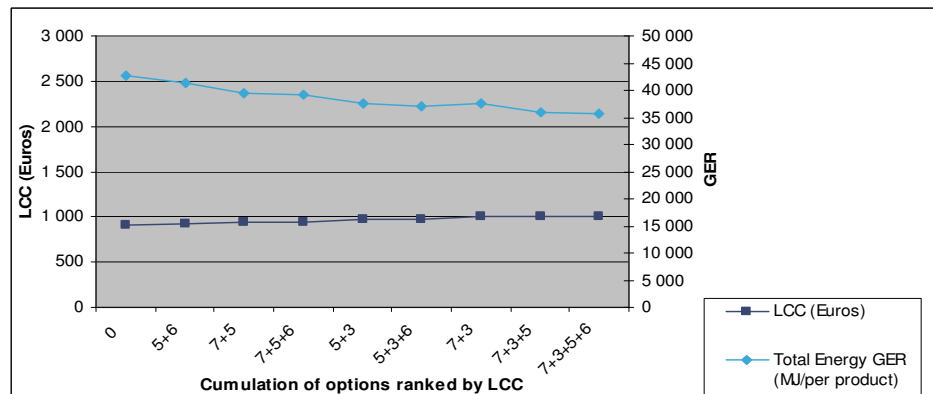

Figure 185: LCC Curve; environmental performance expressed in GER for the vented base case cumulating options

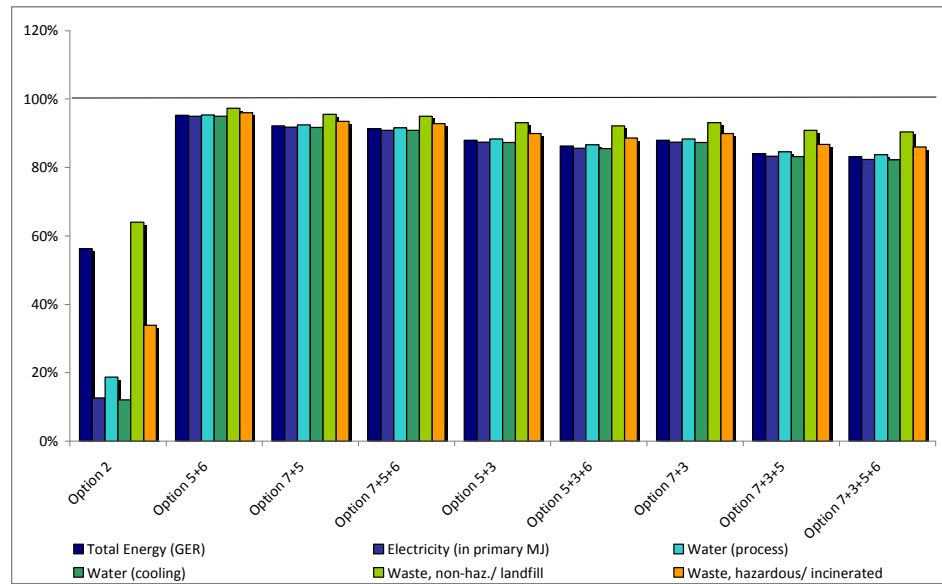

Figure 186: Comparison of the cumulative options (resources & waste) for the base case air vented dryer (ranking by LCC)

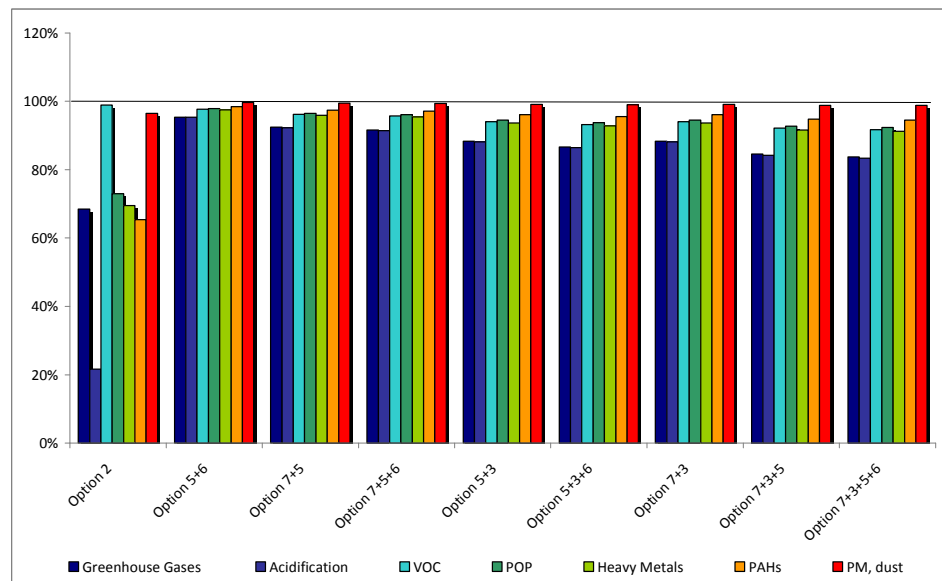

Figure 187: Comparison of the cumulative options (emission to air) for the base case air vented dryer (ranking by LCC)

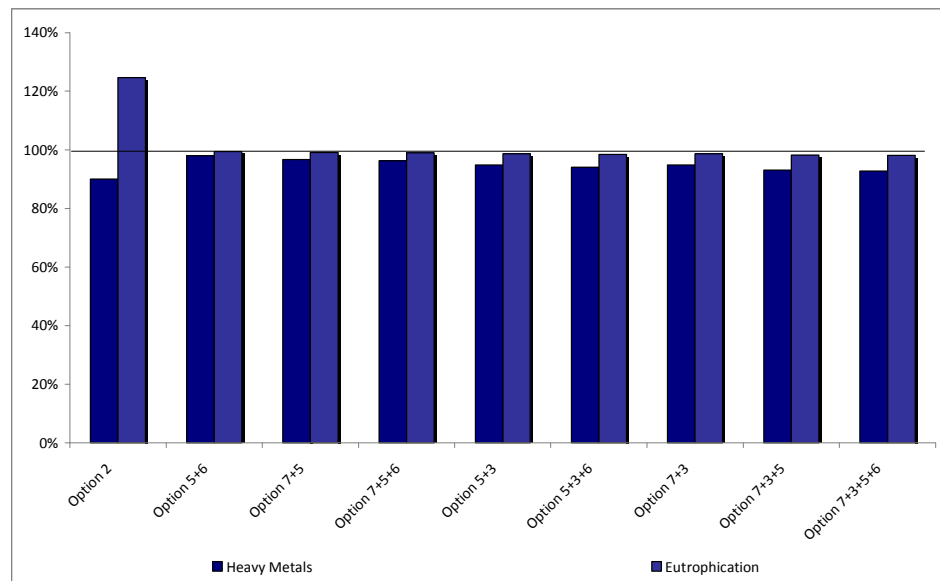

Figure 188: Comparison of the cumulative options (emission to water) for the base case air vented dryer (ranking by LCC)

Combined design options analyzed consist only in an addition of energy savings. Table 122 shows that, combining improvement options could lead to 17% of energy savings, this consumption reduction is not joined to other impact increases. By presenting in parallel the case of gas dryer, we can remark that very higher decrease in consumption is possible, which is joined by the decrease of all the environmental impact indicators (except water eutrophication).

Table 122: Ecoreport results -This table is presented in relative improvement with the air vented base case as reference

Impact	Unit	Option 2	Impact variation with least performing option Option 5 + 6	Impact variation with best performing option Option 7+3+5+6
Other Resources & Waste				
Total Energy (GER)	MJ	44%	5%	17%
of which, electricity (in primary MJ)	MJ	87%	5%	18%
Water (process)	ltr	81%	5%	16%
Water (cooling)	ltr	88%	5%	18%
Waste, non-haz / landfill	g	36%	3%	10%
Waste, hazardous/ incinerated	g	66%	4%	14%
Emissions (Air)				
Greenhouse Gases in GWP100	kg CO2 eq.	32%	5%	16%
Acidification, emissions	g SO2 eq.	78%	5%	17%
Volatile Organic Compounds (VOC)	g	1%	2%	8%
Persistent Organic Pollutants (POP)	ng I-Teq	27%	2%	8%
Heavy Metals	mg Ni eq.	30%	2%	9%
PAHs	mg Ni eq.	35%	2%	6%
Particulate Matter (PM, dust)	g	3%	0%	1%
Emissions (Water)				
Heavy Metals	mg Hg/20	10%	2%	7%
Eutrophication	g PO4	-25%	1%	2%

Note: a positive % means a relative improvement regarding the base case whereas a negative % means a relative worst impact compared to the base case

VII.3.2 Base case Air condenser dryer

Individual improvement options

The Ecoreport analysis of the 8 individual improvement options applicable to the Condenser dryer base case are presented in the following table. Improvements options applicable to full load or only partial load are separated. The table is ranking by payback time of the different individual improvement options.

Table 123: Summary of the cost and benefit effects of implementing individual improvement options for the base case Condenser dryers

N°	Design option	Technologies	Total Energy GER (MJ/per product)	GWP	Electricity Costs (Euros/lifetime)	LCC (Euros)	Payback (Year)	Cost increase (Euros)	TEC saving (%)	BOM modification
0	Condenser Base Case - full load		46 268	2 088	508	1 106				
3	Improved motor concept (incl. control)	Condenser dryers	44 587	2 015	488	1112	11.94	25	4%	no
1	Heat pump condenser dryers	Condenser dryers	27978	1 311	283	1211	13.79	330	39%	yes cf § 2.3.1
4	Heat recovery motor	Condenser dryers	45 547	2 057	499	1118	22.28	20	8%	no
2	Optimized process and system design	Condenser dryers	42904	1941	468	1162	22.68	95	7%	no
5*	Improved insulation	all technologies	44 586	2 015	488	1142	26.26	55	7%	no
0	Condenser Base Case - partial load		48 513	2 186	534	1 129				
6*	Combined drying programs	all technologies	45 801	2 055	507	1120	5.18	15	5%	no
7*	Improved sensor and control systems - load control	all technologies	44108	1981	487	1115	5.99	30	8%	no
8*	Improved sensor and control systems - intelligent load control	all technologies	46012	2064	509	1158	18.98	50	4%	no

The environmental performance can be plotted together with the LCC values. It can be either expressed in:

- Electricity costs (during use phase) over the product life (Euros/product), this reflects the electricity use,
- Total energy consumption during the whole lifetime of the condenser dryer (GER in MJ/product), or
- Global Warming Potential (GWP in kg CO₂ eq./product)

First of all, it can be noticed on the curves that the values of the different indicators do not vary significantly (Option N°1 excluded) from an option to another one. Improvement option leads to rather slight modifications of these three indicators.

45 % of the LCC of a condenser dryer (standard base case) is due to the electricity costs over the lifetime (the product purchase cost represents 50% of the LCC). Consequently, the electricity consumption during use phase (expressed in electricity costs) and the total energy consumption correlate closely with the LCC curve. If we express the environmental performance in terms of GWP (Global Warming Potential) the LCC curve is similar and leads to the same conclusion.

However we can notice for the full load case, that **the Heat Pump improvement option (Option N°1)** does not follow this trend. The 47% energy saving corresponding to the implementation of this option does not compensate the high increase of the purchase price (+60%). Therefore, whereas the electricity costs over the lifetime of this option are the lower of the benchmark (283 Euros), LCC is the higher one (1 211 Euros). Nevertheless this option allows reducing the GWP by 39 % in comparison with the base case, increasing the LCC by only 9%.

Remark: Please note that if the price increase due to the implementation of a heat pump for condenser dryers was lowered to 225 Euros (versus 330 Euros considered as hypothesis in this task) this option would lead to an LCC equal to the one of the base case (1 106 Euros). In task 8, some specific sensitivity analysis will be performed regarding this aspect.

For the partial load case, the implementation of option N°7 (Improved sensor and control systems - load control) leads to the LLCC (1 115 Euros), and reduces by around 9% the values of the 3 indicators in comparison with the base case.

Low variations (Heat pump excluded) between the different options do not allow further significant conclusions and this for the three indicators.

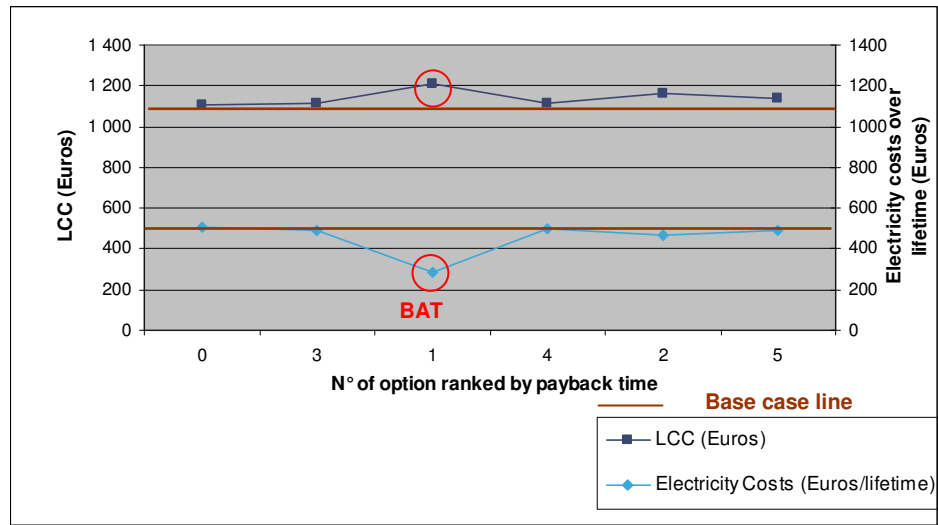

Figure 189: LCC Curve; environmental performance expressed in total electricity costs for the full load condenser base case

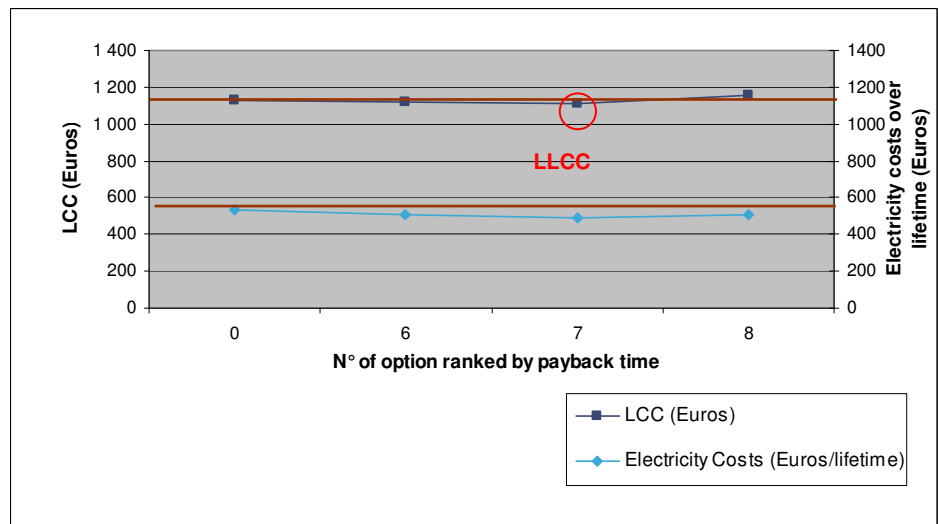

Figure 190: LCC Curve; environmental performance expressed in total electricity costs for the partial load condenser base case

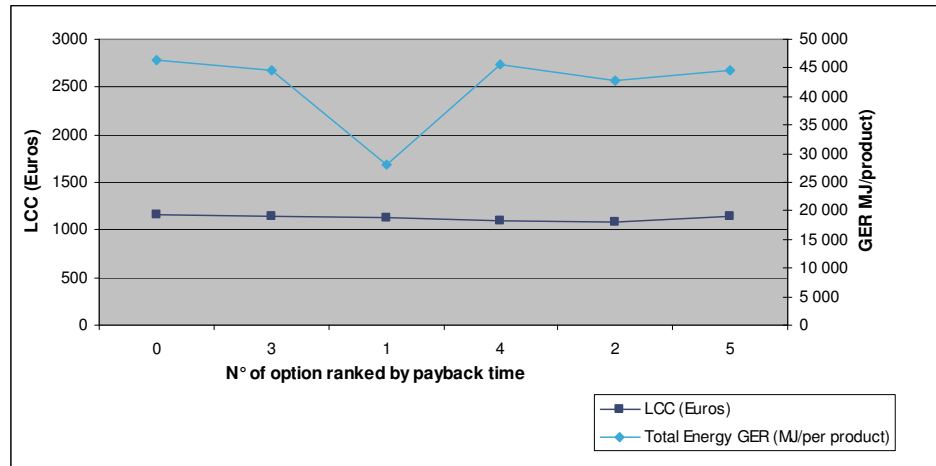

Figure 191 LCC Curve; environmental performance expressed in total energy consumption for the full load condenser base case

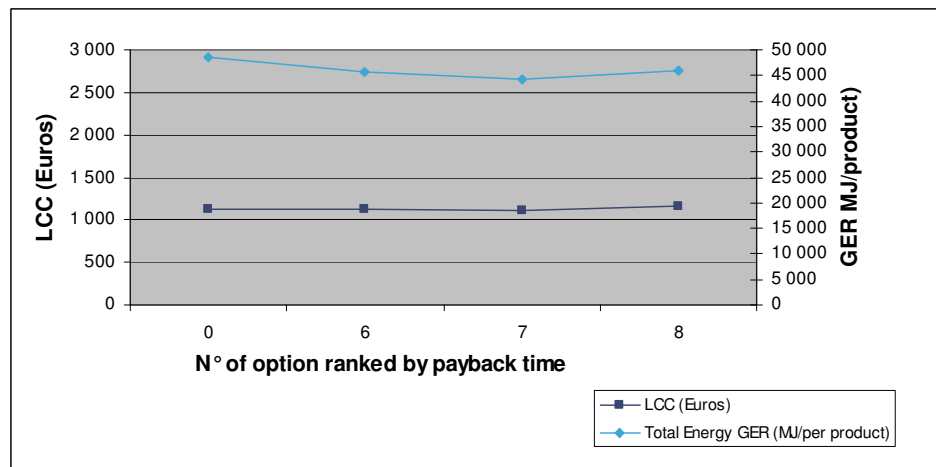

Figure 192: LCC Curve; environmental performance expressed in total energy consumption for the partial load condenser base case

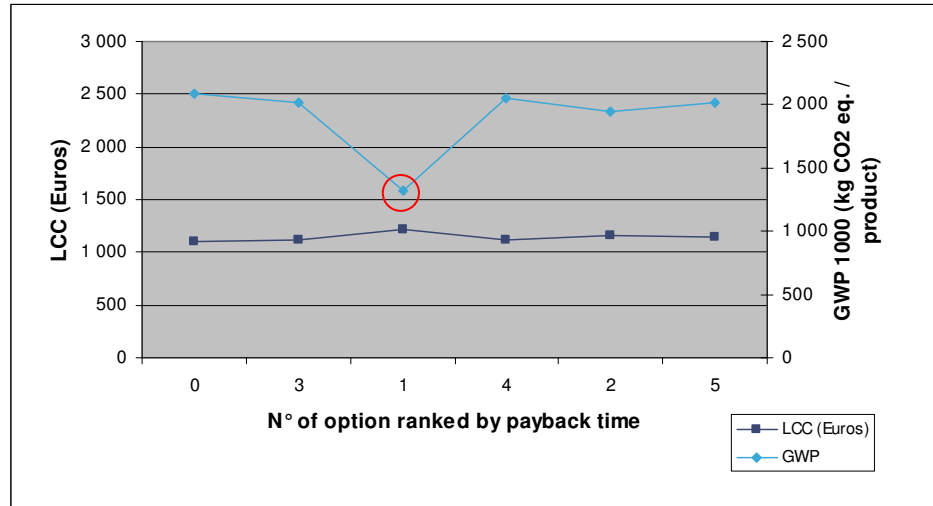

Figure 193: LCC Curve; environmental performance expressed in GWP for the full load condenser base case

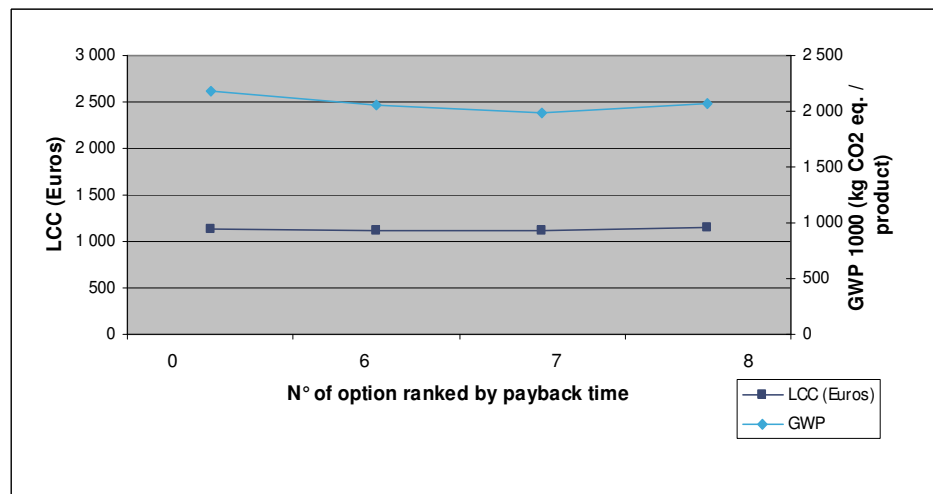

Figure 194: LCC Curve; environmental performance expressed in GWP for the partial load condenser base case

Effect of cumulative options for condenser dryers

General hypothesis regarding cumulative options

The following analysis performed for combined options as presented previously in Task 6 are based on the following assumptions:

The combination of the improvement potential technologies are in general independent from each one, and therefore, the energy savings that can be obtained from the combination of the technologies should be derived most of the time from the addition of the independent savings of the appliances. Slight interactions can appear but do not have misleading influence on the overall result,

However when a reduced effect was supposed, the value of the cumulated savings has been estimated by the experts.

New BOM for combined options have not been considered even if some changes could appear in the material composition,

Only full load improvement options have been cumulated. Partial load are excluded from the scope of accumulation.

In the following table and graphics, cumulated options have been ranked by total LCC.

Table 124: Summary of the cost and benefit effects of implementing improvement options for condenser dryers (full load base case) –options combinations are ranked by total LCC

Combination	Consumption /cycle	Total Energy GER (MJ/ per product)	GWP	Electricity Costs (Euros/lifetime)	LCC (Euros)	Payback (Year)	Cost increase (Euros)	TEC saving (%)
0	3.6	46 268	2 088	508	1 106			
3+4 *	3.43	44 226	1 999	484	1127	17.69	45	4%
5+3	3.32	42 904	1 941	468	1147	19.10	80	7%
5+3+4	3.24	41 943	1 899	457	1156	18.57	100	9%
1+5	1.89	26 812	1 262	267	1216	13.68	350	42%
1+5+3	1.75	25 130	1 189	248	1221	13.55	375	46%

*In the calculation of energy savings for the combination Option 3+4, a potential energy saving of 4.75Wh/kg was considered. Indeed in table 4 of the task 6, it was mentioned that a combination between improved motor concept and heat recovery motor has a reduced effect on the energy savings.

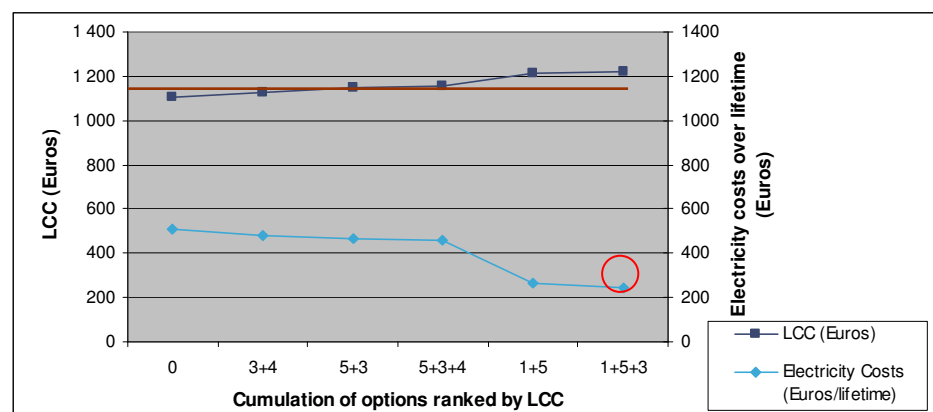

Figure 195: LCC Curve; environmental performance expressed in total electricity costs for the condenser base case cumulating options

These combinations of options do not allow determining any combination leading to a LLCC. All combinations lead to an LCC superior to the one of the base case.

The combined options with the least energy consumption (-50% of electricity costs in comparison with the base case) is the combination of the 3 options 1 + 5 + 3, leading also the higher LCC of the benchmark (+10% in comparison with the base case).

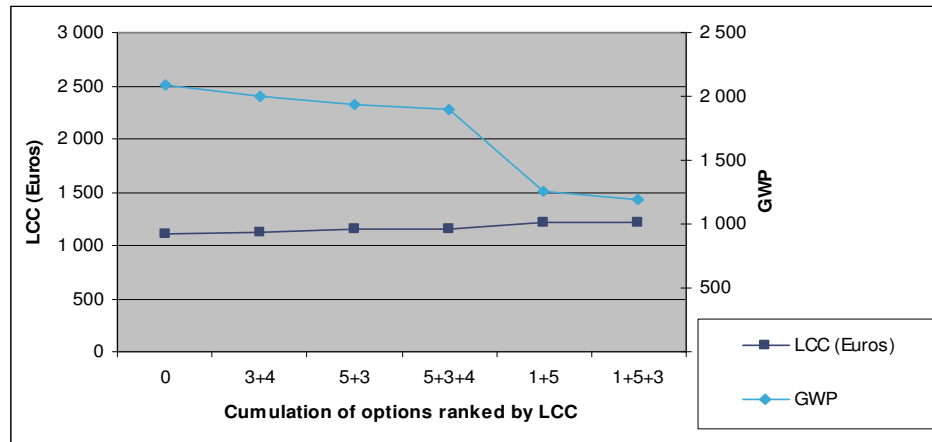

Figure 196: LCC Curve; environmental performance expressed in GWP for the condenser base case cumulating options

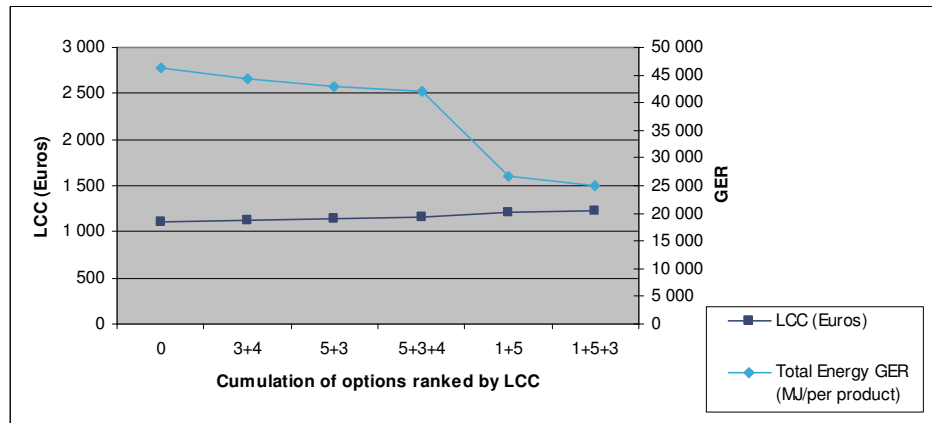

Figure 197: LCC Curve; environmental performance expressed in GER for the condenser base case cumulating options

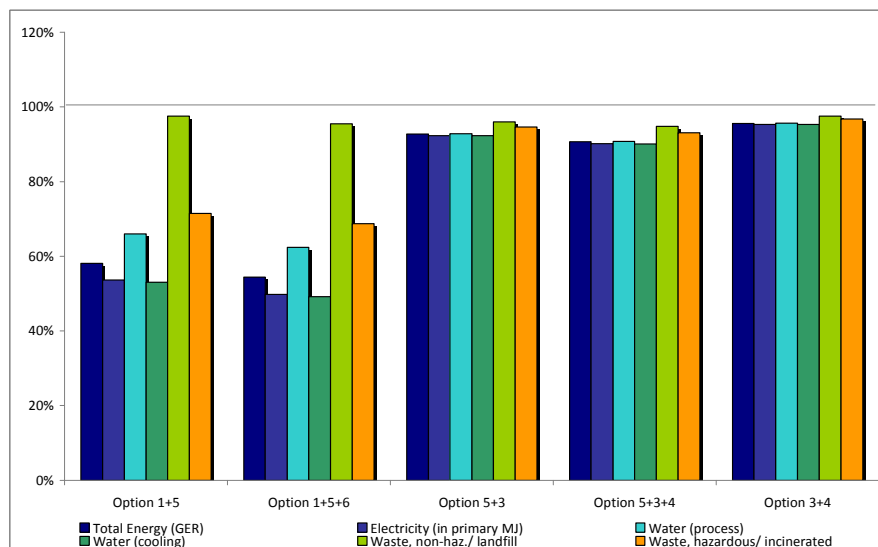

Figure 198: Comparison of the cumulative options (resources & waste) for the base case condenser dryer

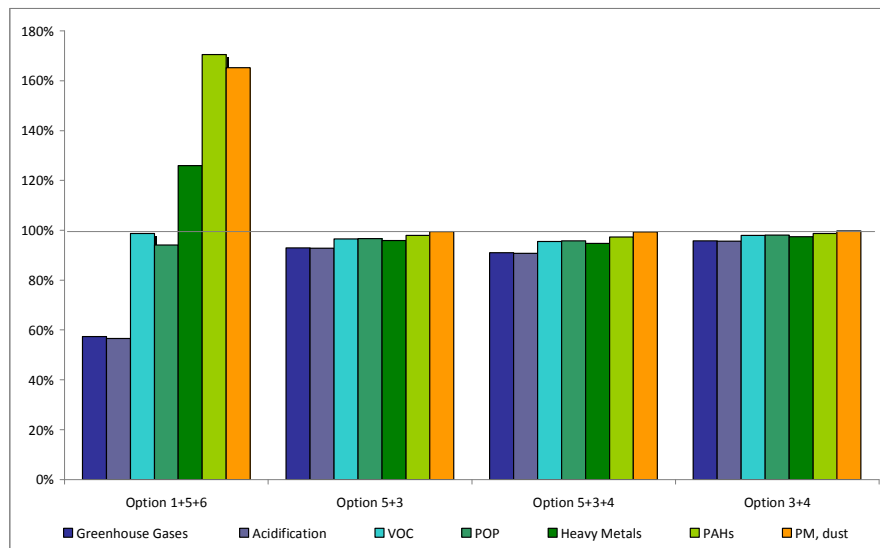

Figure 199: Comparison of the cumulative options (emission to air) for the base case condenser dryer

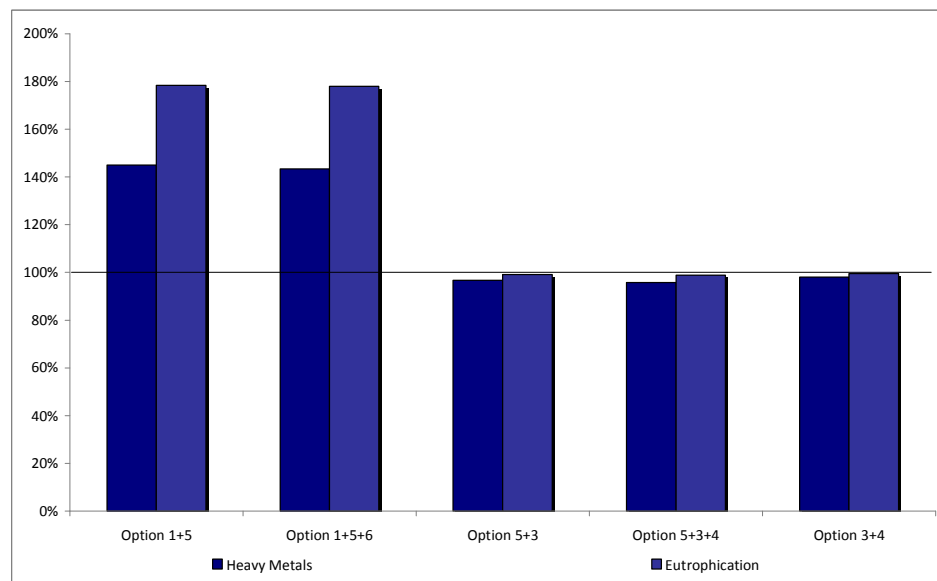

Figure 200: Comparison of the cumulative options (emission to water) for the base case condenser dryer

From the two first combinations, the heat pump technology appears in the combination, so a sharp modification of the impact repartition is observed. Regarding indicator depending on energy (energy, electricity consumption and global warming potential), the decrease of the corresponding indicators has to be pointed. On the other hand, considering the impact on water and on PAH emissions, the modification of the BOM is responsible for an increase of the impact.

The three last combinations consist only in an addition of potential energy savings, so we can observe an improvement which is function of the consumption decrease.

Table 125: Ecoreport results for the least performing option (option3+4) and for the best performing option (1+5+6) – This table is presented in relative improvement with the condenser base case as reference

Indicator	Impact variation with least performing option Option 3+4	Impact variation with best performing option Option 1 + 5 + 6
Other Resources & Waste		
Total Energy (GER)	4%	46%
Electricity (in primary MJ)	5%	50%
Water (process)	4%	38%
Water (cooling)	5%	51%
Waste, non-haz./ landfill	2%	5%
Waste, hazardous/ incinerated	3%	31%
emission (air)		
Greenhouse Gases	4%	43%
Acidification	4%	43%
VOC	2%	1%
POP	2%	6%
Heavy Metals	2%	-26%
PAHs	1%	-71%
PM, dust	0%	-65%
Emission (water)		
Heavy Metals	2%	-43%
Eutrophication	0%	-78%

Note: a positive % means a relative improvement regarding the base case whereas a negative % means a relative worst impact compared to the base case

VII.4 Conclusions

In this task, we have been studying the different improvement options identified in Task 6 in terms of environmental and economic impacts in order to identify most cost effective options.

We have considered in our analysis 8 improvement options for condenser dryers and 11 for vented dryers. Four options identified in Task 6 were not considered mostly because information on costs and energy savings were not accurate.

For the environmental impact assessment analysis, we integrated modified BOM for heat pump condenser dryers and gas dryers. For Heat pump vented dryers, according to the manufacturers, there is no accurate data available at the moment. For other options, material variation was of less than 10%, therefore we did not consider a new BOM. It is important to emphasize this point because the modification of the BOM gives interesting inputs regarding the modification of the environmental impacts.

Regarding the analysis of Life Cycle Assessment, based on the described assumptions, options were identified as less environmental impacting.

On the one hand, one option leads to the lower impacts relating to the majority of the impacts with a decrease of the primary energy consumption by 44%, it is the gas dryer. On the other hand, other options leading to the most important energy (electricity) savings are options using a heat pump (see Figure 201: General comparison of the 5 most energy effective options). But, these energy consumption reductions are linked with major changes in BOM and with the addition of a refrigerant gas. As a consequence, these options are responsible for an increase of water pollution, of PAH emission (due to the use of stainless steel) and for an increase of the end-of-life treatment difficulty for heat pump dryers. In parallel, technical improvements on the existing dryers could lead to 8% in energy savings with no major BOM modifications.

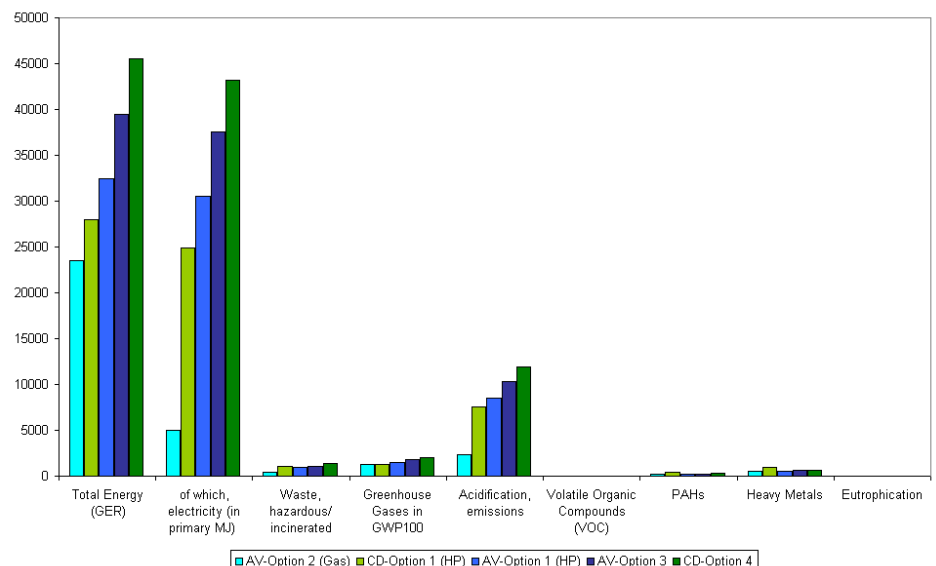

Figure 201: General comparison of the 5 most energy effective options

In order to increase the energy savings, different technical options were combined. And it was observed that the combination of technical improvement on standard air vented and air condenser dryer could lead for example to 17% energy savings for air vented.

Regarding the analysis of Life Cycle Costs, based on the described assumptions, few options were identified as cost effective. Two options, heat pump for condenser and air vented dryers and gas dryers, enable high energy savings but implies higher LCC. For example, Heat Pump condenser dryers improvement option (Option N°1) leads to 39% energy saving and 60% increase of the purchase price (higher LCC).

In task 8, some sensitivity analyses will be performed to better understand the influence of two factors, electricity costs and additional costs for consumers, on the cost effectiveness of those options.

Nevertheless, it should be also noted that some options show interesting results combining LLCC and decrease of energy consumption by around 10%, that is the case especially for the implementation of improved sensor and control systems - load control for condenser dryers (Option N°7) and vented dryers (option 10).

Regarding the combination of options for condenser dryers, no combination leads to a cost effective solution, nevertheless, the combination of options 1, 5 and 3 (heat pump and improved insulation and motor concept) leads to the least energy consumption (-50% of electricity costs in comparison with the base case) but also the higher LCC of the benchmark (+10% in comparison with the base case).

It is the same case for the combination of options for air vented dryers, where no combination leads to a cost effective solution, nevertheless, the combination of options 7, 3, 5 and 6 (exhaust air recovery and improved motor concept and heat recovery) leads to the least energy consumption (-50% of electricity costs in comparison with the base case) but also the higher LCC of the benchmark (+10% in comparison with the base case). It should be reminded that gas dryers and heat pump air vented dryers were not combined in this analysis, mainly because no modified BOM exist for heat pump air vented dryers and because lack of information of the influence of the improvement options on gas consumptions.

Annexes to Task 7

R References

- VHK Van Holsteijn en Kemma BV (2005), MEEuP methodology report, Final Report
- Rüdener, Gensch, Liu (2008) *Vergleich der Umweltauswirkungen und Kosten verschiedener Wäschetrocknungssysteme*, Oeko Institut

S Summary of comments from stakeholders

Submission	Comment	Response
<p>12/22/2008 Öko-Institut e. V. Carl-Otto Gensch</p>	<p>We recommend to perform sensitivity analysos for the options that lead to hih energy savings</p> <p>Why it was not possible to clarify why there is cost ranges ?</p> <p>The option “improved insulation” only requires a software modification, additional costs seem to be rather high - especially in comparison to other improvement options like load control</p> <p>According to your answer to our comment on Task 3 a time-controlled version was foreseen as potential improvement with neg. impacts. Why is this option neglected now?</p> <p>Heat pump dryers include fluorinated Hydrocarbons as cooling agent (currently R 134a). These substances have a high global warming potential (GWP), which can partly compensate the lower GWP through the lower electricity demand during the use phase. However recent investigations by Öko-Institut show, that even if the whole amount of the cooling agent would be released into the environment, heat pump dryers still have a lower overall GWP compared to even B-class condenser dryers. However, the use of refrigerants and their GWP is still an issue, which has to be kept in mind – effective take back and recycling schemes have to be developed to dispose as much of the cooling agent as possible. Furthermore, ecodesign requirements have to be elaborated with respect to the refrigerants’ harm potential to human health and the environment. The overall highest energy saving potential (3 to 4 energy labelling classes) compared to conventional dryers can be reached with heat pump condenser dryers implying also the additional costs for consumers being the highest.</p>	<p>It will be done in task 8 for Heat pump dryers and gas dryers, especially with the following parameters: electricity costs and additional costs for consumers</p> <p>Manufacturers have different cost structures and different access to those technologies and it was not possible to define a more accurate that was acceptable for all manufacturers.</p> <p>This has been discussed with manufacturers and will be checked again.</p> <p>It was not considered in Task 7 because the basecase is already considering time control</p> <p>Informations added in the draft</p>
<p>12/17/2008 LG Claudia Albuquerque</p>	<p>Chapter 3: LLCC and BAT analyses, page 45</p> <p>22 : LCC Curve; environmental performance expressed in GWP for the partial load condenser base case</p>	<p>Ok, it has been changed</p>

Submission	Comment	Response
	On the X-axis of 22, the <i>No. of options ranked by package time</i> values should not be 0-6-7- 8, instead of 0 -3 -1 -4, once this concerns the partial load condenser base case?	
12/18/2008 Viegand & Maagøe Annette Gydesen	<p>In the calculation of the payback time and LLCC you are for option 1-5 for the condenser tumbler and option 1-7 for the air vented tumbler using the condition base case full load (6 kg). In the base case full load you are probably using an annual number of cycles of 88 (the value in table 2) because you consider that the weight of the close should correspond to the weight of the cloths in the real life situation. However the consumers will not only use the tumble dryer 88 times per year but in average 155 times per year.</p> <p>Both the energy consumption and the energy saving potential will be larger when the tumbler is used 155 times at partial load compared to 88 times at full load. Therefore the calculations for options 1-5 for the condenser tumbler and 1-7 for the air vented tumbler will not reflect the real consumer benefits of the improvement options 1-5 and 1-7 respectively.</p> <p>We request that calculations for option 1-5 for condenser tumblers and option 1-7 for air vented tumblers are carried out also for the condition base case partial load.</p> <p>Residual moisture content (RMC) is a better approach for describing the energy efficiency of the washing machine spinning process than the spin speed.</p>	<p>For the options mentioned in standard basecase (full load), we do not have the corresponding energy saving potential at partial load.</p> <p>Moreover, the use in full load wit a coherent number of cycles permits no to take into account a higher energy consumption due to an inadequate use and allows to have a better estimation of the real affordable energy savings if the dryers are used properly.</p> <p>Ok, noted but we will keep the spin speed reference to be coherent along the project and with Lot 14.</p>
12/23/2008 H. Jager (Stichting Natuur&Milieu)	<p>As existing electricity prices differ widely (more than 300%) the use of an average price to calculate payback times are debatable. This means that the range of pay back times is in practice much larger than shown.</p> <p>These are not the cost but the price increase for the consumer. The cost for the producer is much lower (about factor 3 lower).</p> <p>Payback time of 5 year is mentioned, but the table 3 shows the Figures 9.12-8.87.</p> <p>Note: these kind differences are also seen on p. 18</p> <p>It is an omission not to modify the BOM in the case of a heat pump.</p>	<p>Sensitivity analysis regarding electricity tariffs will be performed in Task 8</p> <p>Ok, it has been modified</p> <p>As mentioned, manufacturers did not provide us datd for a modified BOM for</p>

Submission	Comment	Response
	<p>Now the conclusion, as was stated by the authors, is worthless. A changed BOM should be considered.</p> <p>Introduction of heatpump dryers on a large scale will probably decrease the price of the heat pump. Is this taken into account ?</p> <p>This table shows nothing new. Nowadays better performing heat pump dryers are already on the market (see www.top10.hier.nu). The question is which techniques are used to make better performing dryers and that are not taking into account in this study.</p> <p>Not having enough information on gas air vented dryers is a large omission in this study as these dryers are important in the market (f.i. in the USA). In countries with a dense gas grid it can be important alternative.</p> <p>Besides the four parameters mentioned in case of a (heat pump) condenser dryer also the pollution of the heat exchanger has a strong influence on energy demand.</p> <p>“Secondly, the spin speed... <i>could</i> have” is strongly underestimating the influence of spin speed as this variable is more important than many of the investigated improvements. So “could have an influence ” should be exchanged for “has a strong influence”.</p> <p>Ad the measure of cleaning the heat exchanger.</p>	<p>HP air vented dryers because accurate data do not exist</p> <p>It is not taken into account at this stage but in the sensitivity analysis we will consider a decrease of the price of the heat pump considering larger scale production.</p> <p>Ok, note that heat pump dryers have very low market share today.</p> <p>We consider that gas dryers have also been included in our study even if it is true that it is not easily applicable in all countries.</p> <p>Ok, noted</p> <p>Ok modified</p> <p>Added</p>

T Eco-report results for improvement options

Table 126: Improvement insulation option relative improvement compared to the real life AV base case

Life Cycle phases -->		PRODUCTION			DISTRIBUITION	USE	END-OF-LIFE*		TOTAL	
Resources Use and Emissions		Material	Manuf.	Total			Disposal	Recycl.		Total
Materials		unit								
Bulk Plastics	g			0%			0%	0%	0%	
TecPlastics	g			0%			0%	0%	0%	
Ferro	g			0%			0%	0%	0%	
Non-ferro	g			0%			0%	0%	0%	
Coating	g			0%			0%	0%	0%	
Electronics	g			0%			0%	0%	0%	
Misc.	g			0%			0%	0%	0%	
Total weight	g			0%			0%	0%	0%	
Other Resources & Waste		<i>see note!</i>								
Total Energy (GER)	MJ	100%	100%	100%	100%	96%	100%	100%	96%	
of which, electricity (in primary MJ)	MJ	100%	100%	100%	100%	96%	100%	100%	96%	
Water (process)	ltr	100%	100%	100%	100%	96%	100%	100%	96%	
Water (cooling)	ltr	100%	100%	100%	100%	96%	100%	100%	96%	
Waste, non-haz./landfill	g	100%	100%	100%	100%	96%	100%	100%	96%	
Waste, hazardous/incinerated	g	100%	100%	100%	100%	96%	100%	100%	97%	
Emissions (Air)										
Greenhouse Gases in GWP100	kg CO2 eq.	100%	100%	100%	100%	96%	100%	100%	96%	
Ozone Depletion, emissions	mg R-11 eq.				negligible					
Acidification, emissions	g SO2 eq.	100%	100%	100%	100%	96%	100%	100%	96%	
Volatile Organic Compounds (VOC)	g	100%	100%	100%	100%	97%	100%	100%	98%	
Persistent Organic Pollutants (POP)	ng i-Teq	100%	100%	100%	100%	96%	100%	100%	96%	
Heavy Metals	mg Ni eq.	100%	100%	100%	100%	96%	100%	100%	96%	
PAHs	mg Ni eq.	100%	100%	100%	100%	98%	100%	100%	99%	
Particulate Matter (PM, dust)	g	100%	100%	100%	100%	99%	100%	100%	100%	
Emissions (Water)										
Heavy Metals	mg Hg/20	100%	100%	100%	100%	96%	100%	#DIV/0!	96%	
Eutrophication	g PO4	100%	100%	100%	100%	96%	100%	100%	100%	
Persistent Organic Pollutants (POP)	ng i-Teq				negligible					

Table 127: Improvement insulation option relative improvement compared to the real life CD base case

Life Cycle phases -->		PRODUCTION			DISTRIBUITION	USE	END-OF-LIFE*		TOTAL	
Resources Use and Emissions		Material	Manuf.	Total			Disposal	Recycl.		Total
Materials		unit								
Bulk Plastics	g			0%			0%	0%	0%	
TecPlastics	g			0%			0%	0%	0%	
Ferro	g			0%			0%	0%	0%	
Non-ferro	g			0%			0%	0%	0%	
Coating	g			0%			0%	0%	0%	
Electronics	g			0%			0%	0%	0%	
Misc.	g			0%			0%	0%	0%	
Total weight	g			0%			0%	0%	0%	
Other Resources & Waste		<i>see note!</i>								
Total Energy (GER)	MJ	100%	100%	100%	100%	96%	100%	100%	96%	
of which, electricity (in primary MJ)	MJ	100%	100%	100%	100%	96%	100%	100%	96%	
Water (process)	ltr	100%	100%	100%	100%	96%	100%	100%	96%	
Water (cooling)	ltr	100%	100%	100%	100%	96%	100%	100%	96%	
Waste, non-haz./landfill	g	100%	100%	100%	100%	96%	100%	100%	96%	
Waste, hazardous/incinerated	g	100%	100%	100%	100%	96%	100%	100%	97%	
Emissions (Air)										
Greenhouse Gases in GWP100	kg CO2 eq.	100%	100%	100%	100%	96%	100%	100%	96%	
Ozone Depletion, emissions	mg R-11 eq.				negligible					
Acidification, emissions	g SO2 eq.	100%	100%	100%	100%	96%	100%	100%	96%	
Volatile Organic Compounds (VOC)	g	100%	100%	100%	100%	97%	100%	100%	98%	
Persistent Organic Pollutants (POP)	ng i-Teq	100%	100%	100%	100%	96%	100%	100%	96%	
Heavy Metals	mg Ni eq.	100%	100%	100%	100%	97%	100%	100%	98%	
PAHs	mg Ni eq.	100%	100%	100%	100%	98%	100%	100%	99%	
Particulate Matter (PM, dust)	g	100%	100%	100%	100%	99%	100%	100%	100%	
Emissions (Water)										
Heavy Metals	mg Hg/20	100%	100%	100%	100%	96%	100%	100%	96%	
Eutrophication	g PO4	100%	100%	100%	100%	96%	100%	100%	100%	
Persistent Organic Pollutants (POP)	ng i-Teq				negligible					

Table 128: Combined drying option relative improvement compared to the real life AV base case

Life Cycle phases -->		PRODUCTION			DISTRIBUITION	USE	END-OF-LIFE*		TOTAL
Resources Use and Emissions		Material	Manuf.	Total			Disposal	Recycl.	Total
Materials		unit							
Bulk Plastics	g			0%			0%	0%	0%
TecPlastics	g			0%			0%	0%	0%
Ferro	g			0%			0%	0%	0%
Non-ferro	g			0%			0%	0%	0%
Coating	g			0%			0%	0%	0%
Electronics	g			0%			0%	0%	0%
Misc.	g			0%			0%	0%	0%
Total weight	g			0%			0%	0%	0%
Other Resources & Waste		<i>see note!</i>							
Total Energy (GER)	MJ	100%	100%	100%	100%	95%	100%	100%	95%
of which, electricity (in primary MJ)	MJ	100%	100%	100%	100%	95%	100%	100%	95%
Water (process)	ltr	100%	100%	100%	100%	95%	100%	100%	95%
Water (cooling)	ltr	100%	100%	100%	100%	95%	100%	100%	95%
Waste, non-haz./landfill	g	100%	100%	100%	100%	95%	100%	100%	97%
Waste, hazardous/incinerated	g	100%	100%	100%	100%	95%	100%	100%	98%
Emissions (Air)									
Greenhouse Gases in GWP100	kg CO2 eq.	100%	100%	100%	100%	95%	100%	100%	95%
Ozone Depletion, emissions	mg R-11 eq.					negligible			
Acidification, emissions	g SO2 eq.	100%	100%	100%	100%	95%	100%	100%	95%
Volatile Organic Compounds (VOC)	g	100%	100%	100%	100%	96%	100%	100%	98%
Persistent Organic Pollutants (POP)	ng I-Teq	100%	100%	100%	100%	95%	100%	100%	98%
Heavy Metals	mg Ni eq.	100%	100%	100%	100%	95%	100%	100%	97%
PAHs	mg Ni eq.	100%	100%	100%	100%	97%	100%	100%	98%
Particulate Matter (PM, dust)	g	100%	100%	100%	100%	99%	100%	100%	100%
Emissions (Water)									
Heavy Metals	mg Hg/20	100%	100%	100%	100%	95%	100%	100%	98%
Eutrophication	g PO4	100%	100%	100%	100%	95%	100%	100%	98%
Persistent Organic Pollutants (POP)	ng I-Teq					negligible			

Table 129: Combined drying option relative improvement compared to the real life CD base case

Life Cycle phases -->		PRODUCTION			DISTRIBUITION	USE	END-OF-LIFE*		TOTAL
Resources Use and Emissions		Material	Manuf.	Total			Disposal	Recycl.	Total
Materials		unit							
Bulk Plastics	g			0%			0%	0%	0%
TecPlastics	g			0%			0%	0%	0%
Ferro	g			0%			0%	0%	0%
Non-ferro	g			0%			0%	0%	0%
Coating	g			0%			0%	0%	0%
Electronics	g			0%			0%	0%	0%
Misc.	g			0%			0%	0%	0%
Total weight	g			0%			0%	0%	0%
Other Resources & Waste		<i>see note!</i>							
Total Energy (GER)	MJ	100%	100%	100%	100%	95%	100%	100%	95%
of which, electricity (in primary MJ)	MJ	100%	100%	100%	100%	94%	100%	100%	95%
Water (process)	ltr	100%	100%	100%	100%	94%	100%	100%	95%
Water (cooling)	ltr	100%	100%	100%	100%	94%	100%	100%	95%
Waste, non-haz./landfill	g	100%	100%	100%	100%	95%	100%	100%	97%
Waste, hazardous/incinerated	g	100%	100%	100%	100%	94%	100%	100%	96%
Emissions (Air)									
Greenhouse Gases in GWP100	kg CO2 eq.	100%	100%	100%	100%	95%	100%	100%	95%
Ozone Depletion, emissions	mg R-11 eq.					negligible			
Acidification, emissions	g SO2 eq.	100%	100%	100%	100%	94%	100%	100%	95%
Volatile Organic Compounds (VOC)	g	100%	100%	100%	100%	96%	100%	100%	97%
Persistent Organic Pollutants (POP)	ng I-Teq	100%	100%	100%	100%	95%	100%	100%	98%
Heavy Metals	mg Ni eq.	100%	100%	100%	100%	95%	100%	100%	97%
PAHs	mg Ni eq.	100%	100%	100%	100%	97%	100%	100%	98%
Particulate Matter (PM, dust)	g	100%	100%	100%	100%	99%	100%	100%	100%
Emissions (Water)									
Heavy Metals	mg Hg/20	100%	100%	100%	100%	95%	100%	100%	98%
Eutrophication	g PO4	100%	100%	100%	100%	95%	100%	100%	98%
Persistent Organic Pollutants (POP)	ng I-Teq					negligible			

Table 130: Improved sensor control (load control) option relative improvement compared to the real life AV base case

Life Cycle phases -->		PRODUCTION			DISTRI-	USE	END-OF-LIFE*		TOTAL
Resources Use and Emissions		Material	Manuf.	Total	BUTION		Disposal	Recycl.	Total
Materials		unit							
Bulk Plastics	g			0%			0%	0%	0%
TecPlastics	g			0%			0%	0%	0%
Ferro	g			0%			0%	0%	0%
Non-ferro	g			0%			0%	0%	0%
Coating	g			0%			0%	0%	0%
Electronics	g			0%			0%	0%	0%
Misc.	g			0%			0%	0%	0%
Total weight	g			0%			0%	0%	0%
Other Resources & Waste		<i>see note!</i>							
Total Energy (GER)	MJ	100%	100%	100%	100%	91%	100%	100%	91%
of which, electricity (in primary MJ)	MJ	100%	100%	100%	100%	91%	100%	100%	91%
Water (process)	ltr	100%	100%	100%	100%	91%	100%	100%	91%
Water (cooling)	ltr	100%	100%	100%	100%	91%	100%	100%	91%
Waste, non-haz./landfill	g	100%	100%	100%	100%	91%	100%	100%	95%
Waste, hazardous/incinerated	g	100%	100%	100%	100%	91%	100%	100%	92%
Emissions (Air)									
Greenhouse Gases in GWP100	kg CO2 eq.	100%	100%	100%	100%	91%	100%	100%	91%
Ozone Depletion, emissions	mg R-11 eq.					negligible			
Acidification, emissions	g SO2 eq.	100%	100%	100%	100%	91%	100%	100%	91%
Volatile Organic Compounds (VOC)	g	100%	100%	100%	100%	92%	100%	100%	95%
Persistent Organic Pollutants (POP)	ng i-Teq	100%	100%	100%	100%	91%	100%	100%	96%
Heavy Metals	mg Ni eq.	100%	100%	100%	100%	92%	100%	100%	95%
PAHs	mg Ni eq.	100%	100%	100%	100%	95%	100%	100%	97%
Particulate Matter (PM, dust)	g	100%	100%	100%	100%	99%	100%	100%	99%
Emissions (Water)									
Heavy Metals	mg Hg/20	100%	100%	100%	100%	91%	100%	100%	96%
Eutrophication	g PO4	100%	100%	100%	100%	91%	100%	100%	99%
Persistent Organic Pollutants (POP)	ng i-Teq					negligible			

Table 131: Improved sensor control (load control) option relative improvement compared to the CD base case

Life Cycle phases -->		PRODUCTION			DISTRI-	USE	END-OF-LIFE*		TOTAL
Resources Use and Emissions		Material	Manuf.	Total	BUTION		Disposal	Recycl.	Total
Materials		unit							
Bulk Plastics	g			0%			0%	0%	0%
TecPlastics	g			0%			0%	0%	0%
Ferro	g			0%			0%	0%	0%
Non-ferro	g			0%			0%	0%	0%
Coating	g			0%			0%	0%	0%
Electronics	g			0%			0%	0%	0%
Misc.	g			0%			0%	0%	0%
Total weight	g			0%			0%	0%	0%
Other Resources & Waste		<i>see note!</i>							
Total Energy (GER)	MJ	100%	100%	100%	100%	91%	100%	100%	92%
of which, electricity (in primary MJ)	MJ	100%	100%	100%	100%	91%	100%	100%	91%
Water (process)	ltr	100%	100%	100%	100%	91%	#DIV/0!	100%	92%
Water (cooling)	ltr	100%	100%	100%	100%	91%	#DIV/0!	100%	91%
Waste, non-haz./landfill	g	100%	100%	100%	100%	91%	100%	100%	95%
Waste, hazardous/incinerated	g	100%	100%	100%	100%	91%	100%	100%	94%
Emissions (Air)									
Greenhouse Gases in GWP100	kg CO2 eq.	100%	100%	100%	100%	91%	100%	100%	92%
Ozone Depletion, emissions	mg R-11 eq.					negligible			
Acidification, emissions	g SO2 eq.	100%	100%	100%	100%	91%	100%	100%	92%
Volatile Organic Compounds (VOC)	g	100%	100%	100%	100%	91%	100%	100%	95%
Persistent Organic Pollutants (POP)	ng i-Teq	100%	100%	100%	100%	91%	100%	100%	96%
Heavy Metals	mg Ni eq.	100%	100%	100%	100%	91%	100%	#DIV/0!	95%
PAHs	mg Ni eq.	100%	100%	100%	100%	91%	100%	100%	97%
Particulate Matter (PM, dust)	g	100%	100%	100%	100%	91%	100%	100%	99%
Emissions (Water)									
Heavy Metals	mg Hg/20	100%	100%	100%	100%	91%	100%	#DIV/0!	96%
Eutrophication	g PO4	100%	100%	100%	100%	92%	100%	100%	99%
Persistent Organic Pollutants (POP)	ng i-Teq					negligible			

Table 132: Improved sensor control (intelligent load control) option relative improvement compared to the real life AV base case

Life Cycle phases --> Resources Use and Emissions	PRODUCTION			DISTRIBUITION	USE	END-OF-LIFE*		TOTAL	
	Material	Manuf.	Total			Disposal	Recycl.		Total
Materials unit									
Bulk Plastics	g		0%			0%	0%	0%	
TecPlastics	g		0%			0%	0%	0%	
Ferro	g		0%			0%	0%	0%	
Non-ferro	g		0%			0%	0%	0%	
Coating	g		0%			0%	0%	0%	
Electronics	g		0%			0%	0%	0%	
Misc.	g		0%			0%	0%	0%	
Total weight	g		0%			0%	0%	0%	
						<i>see note!</i>			
Other Resources & Waste									
Total Energy (GER)	MJ	100%	100%	100%	100%	95%	100%	100%	95%
of which, electricity (in primary MJ)	MJ	100%	100%	100%	100%	95%	100%	100%	95%
Water (process)	ltr	100%	100%	100%	100%	95%	100%	100%	95%
Water (cooling)	ltr	100%	100%	100%	100%	95%	100%	100%	95%
Waste, non-haz./landfill	g	100%	100%	100%	100%	95%	100%	100%	97%
Waste, hazardous/incinerated	g	100%	100%	100%	100%	95%	100%	100%	96%
Emissions (Air)									
Greenhouse Gases in GWP100	kg CO2 eq.	100%	100%	100%	100%	95%	100%	100%	95%
Ozone Depletion, emissions	mg R-11 eq.					negligible			
Acidification, emissions	g SO2 eq.	100%	100%	100%	100%	95%	100%	100%	95%
Volatile Organic Compounds (VOC)	g	100%	100%	100%	100%	95%	100%	100%	96%
Persistent Organic Pollutants (POP)	ng i-Teq	100%	100%	100%	100%	95%	100%	100%	96%
Heavy Metals	mg Ni eq.	100%	100%	100%	100%	95%	100%	100%	97%
PAHs	mg Ni eq.	100%	100%	100%	100%	97%	100%	100%	96%
Particulate Matter (PM, dust)	g	100%	100%	100%	100%	98%	100%	100%	100%
Emissions (Water)									
Heavy Metals	mg Hg/20	100%	100%	100%	100%	95%	100%	100%	96%
Eutrophication	g PO4	100%	100%	100%	100%	95%	100%	100%	98%
Persistent Organic Pollutants (POP)	ng i-Teq					negligible			

Table 133: Improved sensor control (intelligent load control) option relative improvement compared to the real life CD base case

Life Cycle phases --> Resources Use and Emissions	PRODUCTION			DISTRIBUITION	USE	END-OF-LIFE*		TOTAL	
	Material	Manuf.	Total			Disposal	Recycl.		Total
Materials unit									
Bulk Plastics	g		0%			0%	0%	0%	
TecPlastics	g		0%			0%	0%	0%	
Ferro	g		0%			0%	0%	0%	
Non-ferro	g		0%			0%	0%	0%	
Coating	g		0%			0%	0%	0%	
Electronics	g		0%			0%	0%	0%	
Misc.	g		0%			0%	0%	0%	
Total weight	g		0%			0%	0%	0%	
						<i>see note!</i>			
Other Resources & Waste									
Total Energy (GER)	MJ	100%	100%	100%	100%	95%	100%	100%	96%
of which, electricity (in primary MJ)	MJ	100%	100%	100%	100%	95%	100%	100%	95%
Water (process)	ltr	100%	100%	100%	100%	95%	100%	100%	96%
Water (cooling)	ltr	100%	100%	100%	100%	95%	100%	100%	95%
Waste, non-haz./landfill	g	100%	100%	100%	100%	95%	100%	100%	96%
Waste, hazardous/incinerated	g	100%	100%	100%	100%	95%	100%	100%	97%
Emissions (Air)									
Greenhouse Gases in GWP100	kg CO2 eq.	100%	100%	100%	100%	95%	100%	100%	96%
Ozone Depletion, emissions	mg R-11 eq.					negligible			
Acidification, emissions	g SO2 eq.	100%	100%	100%	100%	95%	100%	100%	96%
Volatile Organic Compounds (VOC)	g	100%	100%	100%	100%	95%	100%	100%	97%
Persistent Organic Pollutants (POP)	ng i-Teq	100%	100%	100%	100%	95%	100%	100%	96%
Heavy Metals	mg Ni eq.	100%	100%	100%	100%	95%	100%	100%	97%
PAHs	mg Ni eq.	100%	100%	100%	100%	95%	100%	100%	96%
Particulate Matter (PM, dust)	g	100%	100%	100%	100%	95%	100%	100%	98%
Emissions (Water)									
Heavy Metals	mg Hg/20	100%	100%	100%	100%	95%	100%	100%	96%
Eutrophication	g PO4	100%	100%	100%	100%	96%	100%	100%	98%
Persistent Organic Pollutants (POP)	ng i-Teq					negligible			

Table 134: Option 1 (Heat pump) option relative improvement compared to the AV base case

Life Cycle phases -->		PRODUCTION			DISTRIBUITION	USE	END-OF-LIFE*		TOTAL
Resources Use and Emissions	unit	Material	Manuf.	Total		Disposal	Recycl.	Total	
Materials									
Bulk Plastics	g			0%		0%	0%	0%	
TecPlastics	g			0%		0%	0%	0%	
Ferro	g			0%		0%	0%	0%	
Non-ferro	g			0%		0%	0%	0%	
Coating	g			0%		0%	0%	0%	
Electronics	g			0%		0%	0%	0%	
Misc.	g			0%		0%	0%	0%	
Total weight	g			0%		0%	0%	0%	
Other Resources & Waste									
							debet		credit
Total Energy (GER)	MJ	100%	100%	100%	100%	75%	100%	100%	75%
of which, electricity (in primary MJ)	MJ	100%	100%	100%	100%	74%	100%	100%	75%
Water (process)	ltr	100%	100%	100%	100%	75%	100%	100%	77%
Water (cooling)	ltr	100%	100%	100%	100%	74%	100%	100%	75%
Waste, non-haz./landfill	g	100%	100%	100%	100%	75%	100%	100%	86%
Waste, hazardous/incinerated	g	100%	100%	100%	100%	75%	100%	100%	80%
Emissions (Air)									
Greenhouse Gases in GWP100	kg CO2 eq.	100%	100%	100%	100%	75%	100%	100%	77%
Ozone Depletion, emissions	mg R-11 eq.	negligible							
Acidification, emissions	g SO2 eq.	100%	100%	100%	100%	82%	100%	100%	83%
Volatile Organic Compounds (VOC)	g	100%	100%	100%	100%	87%	100%	100%	92%
Persistent Organic Pollutants (POP)	ng i-Teq	100%	100%	100%	100%	82%	100%	100%	93%
Heavy Metals	mg Ni eq.	100%	100%	100%	100%	84%	100%	100%	91%
PAHs	mg Ni eq.	100%	100%	100%	100%	92%	100%	100%	95%
Particulate Matter (PM, dust)	g	100%	100%	100%	100%	98%	100%	100%	99%
Emissions (Water)									
Heavy Metals	mg Hg/20	100%	100%	100%	100%	82%	100%	100%	93%
Eutrophication	g PO4	100%	100%	100%	100%	83%	100%	100%	98%
Persistent Organic Pollutants (POP)	ng i-Teq	negligible							

Table 135: Option 2 (Gas dryer) option relative improvement compared to the AV base case

Life Cycle phases -->		PRODUCTION			DISTRIBUITION	USE	END-OF-LIFE*		TOTAL
Resources Use and Emissions	unit	Material	Manuf.	Total		Disposal	Recycl.	Total	
Materials									
Bulk Plastics	g			53%		4503%	-84%	53%	
TecPlastics	g			-53%		1314%	-95%	-53%	
Ferro	g			23%		23%	23%	23%	
Non-ferro	g			49%		49%	49%	49%	
Coating	g			0%		0%	0%	0%	
Electronics	g			-10%		-10%	0%	-10%	
Misc.	g			-11%		-11%	-11%	-11%	
Total weight	g			18%		248%	-5%	18%	
Other Resources & Waste									
							debet		credit
Total Energy (GER)	MJ	118%	112%	116%	100%	54%	116%	116%	96%
of which, electricity (in primary MJ)	MJ	125%	112%	117%	100%	12%	112%	112%	13%
Water (process)	ltr	132%	112%	131%	100%	8%	100%	112%	19%
Water (cooling)	ltr	101%	112%	103%	100%	12%	100%	112%	12%
Waste, non-haz./landfill	g	125%	113%	125%	100%	13%	118%	112%	64%
Waste, hazardous/incinerated	g	125%	114%	125%	100%	12%	112%	112%	34%
Emissions (Air)									
Greenhouse Gases in GWP100	kg CO2 eq.	127%	112%	123%	100%	65%	116%	116%	68%
Acidification, emissions	g SO2 eq.	130%	112%	127%	100%	15%	115%	115%	22%
Volatile Organic Compounds (VOC)	g	123%	114%	122%	100%	94%	114%	115%	99%
Persistent Organic Pollutants (POP)	ng i-Teq	118%	114%	118%	100%	13%	118%	118%	73%
Heavy Metals	mg Ni eq.	131%	114%	130%	100%	22%	116%	116%	70%
PAHs	mg Ni eq.	75%	112%	75%	100%	58%	100%	112%	65%
Particulate Matter (PM, dust)	g	128%	112%	125%	100%	69%	114%	112%	97%
Emissions (Water)									
Heavy Metals	mg Hg/20	143%	114%	143%	100%	14%	117%	117%	90%
Eutrophication	g PO4	138%	112%	138%	100%	21%	117%	112%	55%
Persistent Organic Pollutants (POP)	ng i-Teq	negligible							

Table 136: Option 3 (Exhaust heat recovery) option relative improvement compared to the AV base case

Life Cycle phases -->		PRODUCTION			DISTRI-	USE	END-OF-LIFE*		TOTAL
Resources Use and Emissions		Material	Manuf.	Total	BUTION		Disposal	Recycl.	Total
Materials		unit							
Bulk Plastics	g			0%			0%	0%	0%
TecPlastics	g			0%			0%	0%	0%
Ferro	g			0%			0%	0%	0%
Non-ferro	g			0%			0%	0%	0%
Coating	g			0%			0%	0%	0%
Electronics	g			0%			0%	0%	0%
Misc.	g			0%			0%	0%	0%
Total weight	g			0%			0%	0%	0%
							<i>see note!</i>		
Other Resources & Waste		debit credit							
Total Energy (GER)	MJ	100%	100%	100%	100%	92%	100%	100%	92%
of which, electricity (in primary MJ)	MJ	100%	100%	100%	100%	92%	100%	100%	92%
Water (process)	ltr	100%	100%	100%	100%	92%	100%	100%	92%
Water (cooling)	ltr	100%	100%	100%	100%	92%	100%	100%	92%
Waste, non-haz./landfill	g	100%	100%	100%	100%	92%	100%	100%	96%
Waste, hazardous/incinerated	g	100%	100%	100%	100%	92%	100%	100%	92%
Emissions (Air)									
Greenhouse Gases in GWP100	kg CO2 eq.	100%	100%	100%	100%	92%	100%	100%	92%
Ozone Depletion, emissions	mg R-11 eq.					negligible			
Acidification, emissions	g SO2 eq.	100%	100%	100%	100%	92%	100%	100%	92%
Volatile Organic Compounds (VOC)	g	100%	100%	100%	100%	94%	100%	100%	96%
Persistent Organic Pollutants (POP)	ng i-Teq	100%	100%	100%	100%	92%	100%	100%	96%
Heavy Metals	mg Ni eq.	100%	100%	100%	100%	93%	100%	100%	96%
PAHs	mg Ni eq.	100%	100%	100%	100%	96%	100%	100%	97%
Particulate Matter (PM, dust)	g	100%	100%	100%	100%	99%	100%	100%	99%
Emissions (Water)									
Heavy Metals	mg Hg/20	100%	100%	100%	100%	92%	100%	#DIV/0!	97%
Eutrophication	g PO4	100%	100%	100%	100%	92%	100%	100%	99%
Persistent Organic Pollutants (POP)	ng i-Teq					negligible			

Table 137: Option 4 (Optimised process and system design) option relative improvement compared to the AV base case

Life Cycle phases -->		PRODUCTION			DISTRI-	USE	END-OF-LIFE*		TOTAL
Resources Use and Emissions		Material	Manuf.	Total	BUTION		Disposal	Recycl.	Total
Materials		unit							
Bulk Plastics	g			0%			0%	0%	0%
TecPlastics	g			0%			0%	0%	0%
Ferro	g			0%			0%	0%	0%
Non-ferro	g			0%			0%	0%	0%
Coating	g			0%			0%	0%	0%
Electronics	g			0%			0%	0%	0%
Misc.	g			0%			0%	0%	0%
Total weight	g			0%			0%	0%	0%
							<i>see note!</i>		
Other Resources & Waste		debit credit							
Total Energy (GER)	MJ	100%	100%	100%	100%	92%	100%	100%	92%
of which, electricity (in primary MJ)	MJ	100%	100%	100%	100%	92%	100%	100%	92%
Water (process)	ltr	100%	100%	100%	100%	92%	100%	100%	93%
Water (cooling)	ltr	100%	100%	100%	100%	92%	100%	100%	92%
Waste, non-haz./landfill	g	100%	100%	100%	100%	92%	100%	100%	96%
Waste, hazardous/incinerated	g	100%	100%	100%	100%	92%	100%	100%	94%
Emissions (Air)									
Greenhouse Gases in GWP100	kg CO2 eq.	100%	100%	100%	100%	92%	100%	100%	93%
Ozone Depletion, emissions	mg R-11 eq.					negligible			
Acidification, emissions	g SO2 eq.	100%	100%	100%	100%	92%	100%	100%	93%
Volatile Organic Compounds (VOC)	g	100%	100%	100%	100%	95%	100%	100%	96%
Persistent Organic Pollutants (POP)	ng i-Teq	100%	100%	100%	100%	92%	100%	100%	97%
Heavy Metals	mg Ni eq.	100%	100%	100%	100%	93%	100%	100%	96%
PAHs	mg Ni eq.	100%	100%	100%	100%	96%	100%	100%	98%
Particulate Matter (PM, dust)	g	100%	100%	100%	100%	99%	100%	100%	99%
Emissions (Water)									
Heavy Metals	mg Hg/20	100%	100%	100%	100%	92%	100%	100%	97%
Eutrophication	g PO4	100%	100%	100%	100%	93%	100%	100%	99%
Persistent Organic Pollutants (POP)	ng i-Teq					negligible			

Table 138: Option 5 (Improved motor concept) option relative improvement compared to the AV base case

Life Cycle phases -->		PRODUCTION			DISTRI-	USE	END-OF-LIFE*		TOTAL
Resources Use and Emissions		Material	Manuf.	Total	BUTION	Disposal	Recycl.	Total	
Materials		unit							
Bulk Plastics	g			0%		0%	0%	0%	
TecPlastics	g			0%		0%	0%	0%	
Ferro	g			0%		0%	0%	0%	
Non-ferro	g			0%		0%	0%	0%	
Coating	g			0%		0%	0%	0%	
Electronics	g			0%		0%	0%	0%	
Misc.	g			0%		0%	0%	0%	
Total weight	g			0%		0%	0%	0%	
							<i>see note!</i>		
Other Resources & Waste									
Total Energy (GER)	MJ	100%	100%	100%	100%	98%	100%	100%	98%
of which, electricity (in primary MJ)	MJ	100%	100%	100%	100%	98%	100%	100%	98%
Water (process)	ltr	100%	100%	100%	100%	98%	100%	100%	98%
Water (cooling)	ltr	100%	100%	100%	100%	98%	100%	100%	98%
Waste, non-haz./landfill	g	100%	100%	100%	100%	98%	100%	100%	98%
Waste, hazardous/incinerated	g	100%	100%	100%	100%	98%	100%	100%	97%
Emissions (Air)									
Greenhouse Gases in GWP100	kg CO2 eq.	100%	100%	100%	100%	98%	100%	100%	98%
Ozone Depletion, emissions	mg R-11 eq.				negligible				
Acidification, emissions	g SO2 eq.	100%	100%	100%	100%	98%	100%	100%	98%
Volatile Organic Compounds (VOC)	g	100%	100%	100%	100%	97%	100%	100%	98%
Persistent Organic Pollutants (POP)	ng i-Teq	100%	100%	100%	100%	98%	100%	100%	98%
Heavy Metals	mg Ni eq.	100%	100%	100%	100%	98%	100%	100%	98%
PAHs	mg Ni eq.	100%	100%	100%	100%	98%	100%	100%	98%
Particulate Matter (PM, dust)	g	100%	100%	100%	100%	98%	100%	100%	100%
Emissions (Water)									
Heavy Metals	mg Hg/20	100%	100%	100%	100%	98%	100%	100%	98%
Eutrophication	g PO4	100%	100%	100%	100%	98%	100%	100%	100%
Persistent Organic Pollutants (POP)	ng i-Teq				negligible				

Table 139: Option 6 (Heat recovery motor) option relative improvement compared to the AV base case

Life Cycle phases -->		PRODUCTION			DISTRI-	USE	END-OF-LIFE*		TOTAL
Resources Use and Emissions		Material	Manuf.	Total	BUTION	Disposal	Recycl.	Total	
Materials		unit							
Bulk Plastics	g			0%		0%	0%	0%	
TecPlastics	g			0%		0%	0%	0%	
Ferro	g			0%		0%	0%	0%	
Non-ferro	g			0%		0%	0%	0%	
Coating	g			0%		0%	0%	0%	
Electronics	g			10%		10%	0%	10%	
Misc.	g			0%		0%	0%	0%	
Total weight	g			0%		5%	0%	0%	
							<i>see note!</i>		
Other Resources & Waste									
Total Energy (GER)	MJ	100%	100%	100%	100%	98%	100%	100%	98%
of which, electricity (in primary MJ)	MJ	100%	100%	100%	100%	98%	100%	100%	98%
Water (process)	ltr	100%	100%	100%	100%	98%	100%	100%	98%
Water (cooling)	ltr	100%	100%	100%	100%	98%	100%	100%	98%
Waste, non-haz./landfill	g	100%	100%	100%	100%	98%	100%	100%	98%
Waste, hazardous/incinerated	g	100%	100%	100%	100%	98%	100%	100%	98%
Emissions (Air)									
Greenhouse Gases in GWP100	kg CO2 eq.	100%	100%	100%	100%	98%	100%	100%	98%
Ozone Depletion, emissions	mg R-11 eq.				negligible				
Acidification, emissions	g SO2 eq.	100%	100%	100%	100%	98%	100%	100%	98%
Volatile Organic Compounds (VOC)	g	100%	100%	100%	100%	97%	100%	100%	98%
Persistent Organic Pollutants (POP)	ng i-Teq	100%	100%	100%	100%	98%	100%	100%	98%
Heavy Metals	mg Ni eq.	100%	100%	100%	100%	98%	100%	100%	98%
PAHs	mg Ni eq.	100%	100%	100%	100%	98%	100%	100%	98%
Particulate Matter (PM, dust)	g	100%	100%	100%	100%	98%	100%	100%	100%
Emissions (Water)									
Heavy Metals	mg Hg/20	100%	100%	100%	100%	98%	100%	100%	98%
Eutrophication	g PO4	100%	100%	100%	100%	98%	100%	100%	98%
Persistent Organic Pollutants (POP)	ng i-Teq				negligible				

Table 140: Option 8 (Mix airflow system) option relative improvement compared to the AV base case

Life Cycle phases -->		PRODUCTION			DISTRI- BUTION	USE	END-OF-LIFE*		TOTAL
Resources Use and Emissions		Material	Manuf.	Total		Disposal	Recycl.	Total	
Materials		unit							
Bulk Plastics	g			0%		0%	0%	0%	
TecPlastics	g			0%		0%	0%	0%	
Ferro	g			0%		0%	0%	0%	
Non-ferro	g			0%		0%	0%	0%	
Coating	g			0%		0%	0%	0%	
Electronics	g			0%		0%	0%	0%	
Misc.	g			0%		0%	0%	0%	
Total weight	g			0%		0%	0%	0%	
							<i>see note!</i>		
Other Resources & Waste		debit credit							
Total Energy (GER)	MJ	100%	100%	100%	100%	93%	100%	100%	93%
of which, electricity (in primary MJ)	MJ	100%	100%	100%	100%	93%	100%	100%	93%
Water (process)	ltr	100%	100%	100%	100%	93%	100%	100%	94%
Water (cooling)	ltr	100%	100%	100%	100%	93%	100%	100%	93%
Waste, non-haz./landfill	g	100%	100%	100%	100%	93%	100%	100%	96%
Waste, hazardous/incinerated	g	100%	100%	100%	100%	93%	100%	100%	94%
Emissions (Air)									
Greenhouse Gases in GWP100	kg CO2 eq.	100%	100%	100%	100%	93%	100%	100%	94%
Ozone Depletion, emissions	mg R-11 eq.				negligible				
Acidification, emissions	g SO2 eq.	100%	100%	100%	100%	93%	100%	100%	93%
Volatile Organic Compounds (VOC)	g	100%	100%	100%	100%	95%	100%	100%	97%
Persistent Organic Pollutants (POP)	ng i-Teq	100%	100%	100%	100%	93%	100%	100%	97%
Heavy Metals	mg Ni eq.	100%	100%	100%	100%	94%	100%	100%	96%
PAHs	mg Ni eq.	100%	100%	100%	100%	97%	100%	100%	98%
Particulate Matter (PM, dust)	g	100%	100%	100%	100%	98%	100%	100%	99%
Emissions (Water)									
Heavy Metals	mg Hg/20	100%	100%	100%	100%	93%	100%	100%	97%
Eutrophication	g PO4	100%	100%	100%	100%	94%	100%	100%	98%
Persistent Organic Pollutants (POP)	ng i-Teq				negligible				

Table 141: Option 1 (Heat pump) option relative improvement compared to the CD base case

Life Cycle phases -->		PRODUCTION			DISTRI- BUTION	USE	END-OF-LIFE*		TOTAL
Resources Use and Emissions		Material	Manuf.	Total		Disposal	Recycl.	Total	
Materials		unit							
Bulk Plastics	g			111%		111%	111%	111%	
TecPlastics	g			147%		147%	147%	147%	
Ferro	g			138%		138%	138%	138%	
Non-ferro	g			230%		230%	230%	230%	
Coating	g			100%		100%	100%	100%	
Electronics	g			54%		54%	100%	54%	
Misc.	g			195%		195%	195%	195%	
Total weight	g			131%		94%	135%	131%	
							<i>see note!</i>		
Other Resources & Waste		debit credit							
Total Energy (GER)	MJ	148%	122%	141%	100%	54%	123%	113%	107%
of which, electricity (in primary MJ)	MJ	144%	122%	129%	100%	53%	113%	113%	106%
Water (process)	ltr	218%	121%	216%	100%	53%	100%	113%	113%
Water (cooling)	ltr	110%	121%	112%	100%	53%	100%	113%	113%
Waste, non-haz./landfill	g	149%	126%	147%	100%	53%	113%	113%	113%
Waste, hazardous/incinerated	g	118%	160%	118%	100%	53%	113%	113%	113%
Emissions (Air)									
Greenhouse Gases in GWP100	kg CO2 eq.	157%	122%	147%	100%	54%	124%	114%	111%
Ozone Depletion, emissions	mg R-11 eq.				negligible				
Acidification, emissions	g SO2 eq.	73%	18%	61%	2%	1%	46%	0%	298%
Volatile Organic Compounds (VOC)	g	3354%	35704%	33889%	192%	2863%	3556%	0%	3803%
Persistent Organic Pollutants (POP)	ng i-Teq	74%	1%	70%	148%	45%	0%	100%	-8%
Heavy Metals	mg Ni eq.	3%	67%	34%	6525%	205%	1077%	100%	1062%
PAHs	mg Ni eq.	0%	0%	0%	0%	0%	100%	0%	17%
Particulate Matter (PM, dust)	g	0%	0%	0%	0%	0%	0%	0%	165%
Emissions (Water)									
Heavy Metals	mg Hg/20	217%	160%	217%	100%	56%	120%	100%	142%
Eutrophication	g PO4	192%	118%	190%	100%	66%	128%	113%	118%
Persistent Organic Pollutants (POP)	ng i-Teq				negligible				

Table 142: Option 2 (Optimised process & System design) option relative improvement compared to the CD base case

Life Cycle phases -->		PRODUCTION			DISTRI-	USE	END-OF-LIFE*		TOTAL
Resources Use and Emissions		Material	Manuf.	Total	BUTION		Disposal	Recycl.	Total
Materials		unit							
Bulk Plastics	g			100%			100%	100%	100%
TecPlastics	g			100%			100%	100%	100%
Ferro	g			100%			100%	100%	100%
Non-ferro	g			100%			100%	100%	100%
Coating	g			100%			100%	100%	100%
Electronics	g			100%			100%	100%	100%
Misc.	g			100%			100%	100%	100%
Total weight	g			100%			100%	100%	100%
							<i>see note!</i>		
Other Resources & Waste									
Total Energy (GER)	MJ	100%	100%	100%	100%	92%	100%	100%	93%
of which, electricity (in primary MJ)	MJ	100%	100%	100%	100%	92%	100%	100%	92%
Water (process)	ltr	100%	100%	100%	100%	92%	100%	100%	92%
Water (cooling)	ltr	100%	100%	100%	100%	92%	100%	100%	92%
Waste, non-haz./landfill	g	100%	100%	100%	100%	92%	100%	100%	96%
Waste, hazardous/incinerated	g	100%	100%	100%	100%	92%	100%	100%	95%
Emissions (Air)									
Greenhouse Gases in GWP100	kg CO2 eq.	100%	100%	100%	100%	92%	100%	100%	93%
Ozone Depletion, emissions	mg R-11 eq.				negligible				
Acidification, emissions	g SO2 eq.	100%	100%	100%	100%	92%	100%	100%	93%
Volatile Organic Compounds (VOC)	g	100%	100%	100%	100%	94%	100%	100%	96%
Persistent Organic Pollutants (POP)	ng i-Teq	100%	100%	100%	100%	92%	100%	100%	97%
Heavy Metals	mg Ni eq.	100%	100%	100%	100%	93%	100%	100%	96%
PAHs	mg Ni eq.	100%	100%	100%	100%	96%	100%	100%	98%
Particulate Matter (PM, dust)	g	100%	100%	100%	100%	99%	100%	100%	99%
Emissions (Water)									
Heavy Metals	mg Hg/20	100%	100%	100%	100%	92%	100%	100%	97%
Eutrophication	g PO4	100%	100%	100%	100%	93%	100%	100%	98%
Persistent Organic Pollutants (POP)	ng i-Teq				negligible				

Table 143: Option 4 (Heat recovery motor) option relative improvement compared to the CD base case

Life Cycle phases -->		PRODUCTION			DISTRI-	USE	END-OF-LIFE*		TOTAL
Resources Use and Emissions		Material	Manuf.	Total	BUTION		Disposal	Recycl.	Total
Materials		unit							
Bulk Plastics	g			100%			100%	100%	100%
TecPlastics	g			100%			100%	100%	100%
Ferro	g			100%			100%	100%	100%
Non-ferro	g			100%			100%	100%	100%
Coating	g			100%			100%	100%	100%
Electronics	g			100%			100%	100%	100%
Misc.	g			100%			100%	100%	100%
Total weight	g			100%			100%	100%	100%
							<i>see note!</i>		
Other Resources & Waste									
Total Energy (GER)	MJ	100%	100%	100%	100%	98%	100%	100%	98%
of which, electricity (in primary MJ)	MJ	100%	100%	100%	100%	98%	100%	100%	98%
Water (process)	ltr	100%	100%	100%	100%	98%	100%	100%	98%
Water (cooling)	ltr	100%	100%	100%	100%	98%	100%	100%	98%
Waste, non-haz./landfill	g	100%	100%	100%	100%	98%	100%	100%	98%
Waste, hazardous/incinerated	g	100%	100%	100%	100%	98%	100%	100%	98%
Emissions (Air)									
Greenhouse Gases in GWP100	kg CO2 eq.	100%	100%	100%	100%	98%	100%	100%	98%
Ozone Depletion, emissions	mg R-11 eq.				negligible				
Acidification, emissions	g SO2 eq.	100%	100%	100%	100%	98%	100%	100%	98%
Volatile Organic Compounds (VOC)	g	100%	100%	100%	100%	93%	100%	100%	99%
Persistent Organic Pollutants (POP)	ng i-Teq	100%	100%	100%	100%	98%	100%	100%	99%
Heavy Metals	mg Ni eq.	100%	100%	100%	100%	93%	100%	100%	99%
PAHs	mg Ni eq.	100%	100%	100%	100%	93%	100%	100%	100%
Particulate Matter (PM, dust)	g	100%	100%	100%	100%	100%	100%	100%	100%
Emissions (Water)									
Heavy Metals	mg Hg/20	100%	100%	100%	100%	98%	100%	100%	99%
Eutrophication	g PO4	100%	100%	100%	100%	98%	100%	100%	100%
Persistent Organic Pollutants (POP)	ng i-Teq				negligible				

Table 144: Option 3 (Improved motor concept) option relative improvement compared to the CD base case

Life Cycle phases -->	PRODUCTION			DISTRI-	USE	END-OF-LIFE*		TOTAL
Resources Use and Emissions	Material	Manuf.	Total	BUTION		Disposal	Recycl.	Total
Materials								
unit								
Bulk Plastics	g		100%			100%	100%	100%
TecPlastics	g		100%			100%	100%	100%
Ferro	g		100%			100%	100%	100%
Non-ferro	g		100%			100%	100%	100%
Coating	g		100%			100%	100%	100%
Electronics	g		90%			80%	100%	90%
Misc.	g		100%			100%	100%	100%
Total weight	g		100%			95%	100%	100%
						<i>see note!</i>		
Other Resources & Waste								
						debit credit		
Total Energy (GER)	MJ	100%	100%	100%	100%	96%	100%	96%
of which, electricity (in primary MJ)	MJ	100%	100%	100%	100%	96%	100%	96%
Water (process)	ltr	100%	100%	100%	100%	96%	100%	96%
Water (cooling)	ltr	100%	100%	100%	100%	96%	100%	96%
Waste, non-haz./landfill	g	100%	100%	100%	100%	96%	100%	96%
Waste, hazardous/incinerated	g	100%	100%	100%	100%	96%	100%	97%
Emissions (Air)								
Greenhouse Gases in GWP100	kg CO2 eq.	100%	100%	100%	100%	96%	100%	96%
Ozone Depletion, emissions	mg P-ll eq.				negligible			
Acidification, emissions	g SO2 eq.	100%	100%	100%	100%	96%	100%	96%
Volatile Organic Compounds (VOC)	g	100%	100%	100%	100%	97%	100%	98%
Persistent Organic Pollutants (POP)	ng i-Teq	100%	100%	100%	100%	96%	100%	96%
Heavy Metals	mg Ni eq.	100%	100%	100%	100%	97%	100%	98%
PAHs	mg Ni eq.	100%	100%	100%	100%	98%	100%	99%
Particulate Matter (PM, dust)	g	100%	100%	100%	100%	99%	100%	100%
Emissions (Water)								
Heavy Metals	mg Hg/20	100%	100%	100%	100%	96%	100%	96%
Eutrophication	g PO4	100%	100%	100%	100%	96%	100%	99%
Persistent Organic Pollutants (POP)	ng i-Teq				negligible			

VIII Task 8: Scenario-, policy-, impact- and sensitivity analysis

VIII.1 Policy review

In this section, the main policy measures existing and planned worldwide for laundry dryers will be summarised and tentatively compared with those existing in the EU. It should be stressed that an exhaustive and more detailed analysis of the specific legislative context in each country has already been performed in Task 1 (especially detailed in Annexe in Task 1).

VIII.1.1 Global overview of policy instruments in place worldwide to foster the environmental performance of energy using products

The major types of policy instruments to foster ecodesign practices and improve the environmental performance of products can be grouped in the following 3 categories, depending on the level of power and constraint at the disposal of government, the stakeholders involved and the market failures addressed:

- regulatory instruments
- voluntary instruments
- financial instruments

Regulatory instruments are usually introduced when it is recognised that market failures would not allow economic instruments alone to reach the objective of the environmental policy. Standards usually impose a specific feature to be installed or banned (prescriptive standards), a minimum energy or water efficiency performance (MEPS) to be achieved, or a class average energy value to be reached. MEPS are usually used to remove the least efficient products within a category. Displaying labels at point of sale can also be required, in order to modify the selection criteria of consumers by drawing their attention to e.g. the energy consumption of household appliances, thus allowing them to make rational economic decisions and rewarding manufacturers for their efforts in product improvement. Historically, mandatory labels have usually taken the form of comparative labels while most voluntary labels are endorsement labels but this is not systematic.

Voluntary instruments rely on stakeholders to achieve policy objectives without the command and control provided by regulations. They may comprise voluntary labelling schemes, voluntary agreements with industrials (where industrials agree to carry out self-regulation), programmes and projects aimed at improving both public awareness and technical skills of industrials, as well as R&D programmes.

Financial instruments include economic incentives and fiscal measures. They aim to encourage investment in better performing products and processes by reducing the investment cost, either directly (economic incentives) or indirectly (fiscal incentives).

All these instruments are combined in market transformation strategies to create changes in markets, so that “business as usual” practices become as close as possible to best available technologies and manufacturers are stimulated to innovate and offer better products to consumers. The main objective of these strategies is to find the right balance between technology push (“pushing” the market, ensuring better products are produced and marketed) and market pull (“pulling” the market, creating consumer demand for better products), as illustrated in the following figure for energy-efficient equipment: Effective market surveillance and compliance enforcement is also a key elements in these policies.

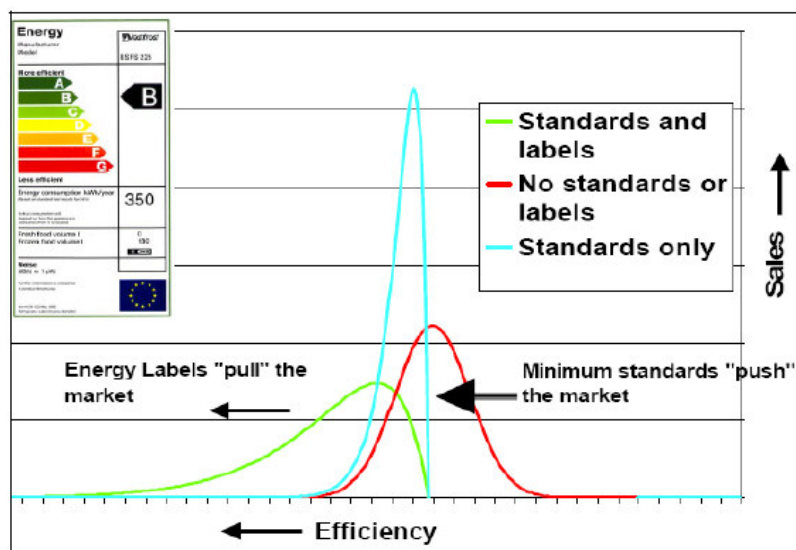

Figure 202 : MEPS and labels, an illustration of market "push" and "pull"

Source: EC (2008)

VIII.1.2 Existing policy measures in Europe and outside Europe

Minimum Energy Performance Standards (MEPS)

No European MEPS exist for laundry dryers. Outside Europe, few countries have already introduced mandatory legislation for laundry dryers (e.g. Canada and USA). In Canada, this takes the form of MEPS combined with a mandatory energy label (Energiguide), whereas in the U.S. only MEPS are in place (see details in Annex of Task 1). Moreover, in two other countries, interesting schemes under discussion concern MEPS:

In Switzerland, according recent information sent by S.A.F.E. (Swiss agency for efficient energy use) during the consultation process of this project, the Swiss government is considering to set labelling class A as MEPS for laundry dryers from 2012 onwards (in consultation process). This means that only heat pump dryers would be on the Swiss market from 2012. I

In Australia, key industry representatives and Australian authorities have been discussing since 2007 a range of issues, mainly relating to energy labelling and MEPS for white goods and air conditioners. Those discussions include the opportunity to include MEPS on standby for dryers which would be implemented as an adjunct to dryer energy labelling in order to deal with the issue in a timely manner.

Labels

Mandatory comparative Energy label

In Europe, tumble dryers are the object of an implementing directive (1995/13/EC) under the Energy Labelling Directive (92/75/EEC). It requires that appliances be labelled to show their power consumption in such a manner that it is possible to compare the efficiency with that of other makes and models. Only electric mains operated household tumble dryers are covered by this implementing directive. Appliances that can also use other energy sources are excluded, as are combined washer-dryers.

Measurements for determining the energy consumption are to be carried out in accordance with the latest edition of the European test standard EN 61121 (i.e. EN 61121: October 2005) (For noise emissions, the noise measurement standards are the relevant parts of EN 60704).

Current energy label for tumble dryers

The label for tumble dryers currently stands as follows:

European energy label for tumble dryers

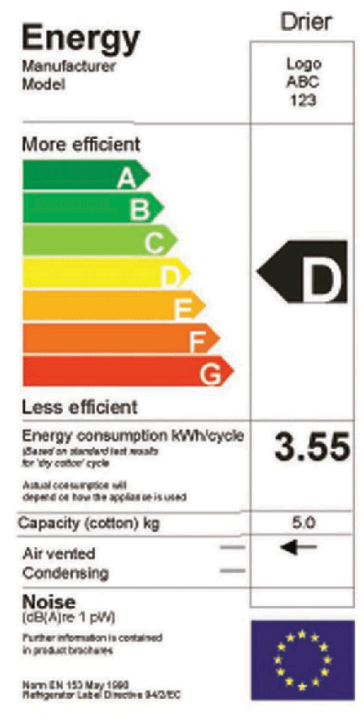

Energy efficiency classes for tumble dryers

ENERGY EFFICIENCY CLASS	Energy consumption 'C'* (kWh/ kg load),	
	Air vented dryers	Condenser dryers
A	$C \leq 0.51$	$C \leq 0.55$
B	$0.51 < C \leq 0.59$	$0.55 < C \leq 0.64$
C	$0.59 < C \leq 0.67$	$0.64 < C \leq 0.73$
D	$0.67 < C \leq 0.75$	$0.73 < C \leq 0.82$
E	$0.75 < C \leq 0.83$	$0.82 < C \leq 0.91$
F	$0.83 < C \leq 0.91$	$0.91 < C \leq 1.00$
G	$C > 0.91$	$C > 1.00$

*Using test procedures of the harmonised standards referred to in Article 1 (2) of Directive 1995/13/EC with 'dry cotton cycle'

Information included in the label

1. Supplier's name or trade mark.
2. Supplier's model identifier.
3. Energy efficiency class of the appliance.
4. There is provision for displaying the EU eco-label (but none exist)
5. Energy consumption in kWh per cycle, for 'dry cotton cycle'
6. Rated capacity of cotton, in kg,
7. Type of appliance: air vented or condensing
8. Where applicable, noise level

Additional information included in the fiche

1. Water consumption for 'dry cotton' programme cycle, if applicable.
2. Drying time for 'dry cotton' cycle.
3. Energy consumption, rated capacity of cotton, water consumption and drying time in respect of the 'iron dry cotton' and 'easy care textiles' programmes (may be omitted if there is no such cycle on the machines in question) and suppliers may include these information in points in respect of other drying cycles.
4. Average annual consumption of energy (and water if applicable) based on the drying of 150 kg using 'dry cotton', plus 280 kg using 'iron-dry' cotton, plus 150 kg using 'easy care' textile programmes, expressed as 'estimated annual consumption for a four person household normally using a drier'.
5. Type of appliance, air vented or condensing,
6. Where applicable, 'noise'.

Calculations for the energy efficiency classes

It should be noted that the standard considers that, under certain climatic conditions, air vented tumble dryers which are externally vented may consume additional energy where the indoor temperature is lower or higher than the outdoor air temperature. In this case it is assumed that the exhaust air is vented outside and replaced through the intake of outdoor air into the building. In a separate measurement, the flow rate of exhaust air is measured during empty operation of the tumble dryer without heating according to ISO 5167-1. Energy losses are then assumed to be proportional to the flow rate and the time (hence the correction factor for vented dryers). Currently, this is accounted for by defining two different scales for the energy efficiency rating for the label.

It should also be reminded that, in order to maintain the classification unchanged after modifications in the testing conditions compared to the 1999 standard, the energy consumption E measured under the new conditions requested by the standard EN 61121: October 2005 (60% of initial moisture instead of 70%, 23 °C for ambient temperature instead of 20 °C, 55% for ambient humidity instead of 65%) is corrected as follows:

- for condenser dryers by multiplying E by 1,14:

$$C = E \times 1,14$$

- for vented dryers by the calculation of the equation:

$$C = E \times 1,14 + 0,08 \text{ [kWh / h]} \times t[\text{h}]$$

Where $t[\text{h}]$ is the total program time expressed in hours.

A new edition of the EN 61121 standard should be released in 2009 after revision by the maintenance team. It should not include major modifications, but should allow more precision in the results.

Programme portfolio

The current requirements of EN 61121 imply that at least 15 tests be carried out to provide the information required on the label and accompanying fiche, as required in the directive on tumble dryers energy labelling (the measures from a minimum of 5 tests should be averaged to obtain a value for the energy consumption for each of the 3 types of programmes: 'dry cotton', 'iron-dry' cotton and 'easy care').

Tolerance

A certain "tolerance" is defined under the energy labelling scheme to take into account all the different sources of variation whenever authorities verify a declared value. The tolerance under the EN 61121: 2005 standard is 15 %.

Conformity assessment and enforcement

The Directives are based solely on self-assessment by the manufacturer although supporting documentation is required.

Since the Directives are about the product information provided by manufacturers, the implementing regulations fall within existing consumer protection legislation dealing with the description of goods by those selling them, and enforcement is dealt with in the same way as for other retail complaints.

Revision of the Energy Labelling Directive and assessment of the energy label for tumble dryers

The Energy Labelling Framework Directive 1992/75/EEC is currently being reviewed. As part of the process, a public consultation was carried out in 2008. So far, only individual comments by stakeholders are available. On the basis of our analysis:

- Most respondents consider that the energy label has had a significant and positive impact in driving the European appliance market towards better performing products.
- They agree to the general principle of reinforcing the use of energy labelling in order to more vigorously contribute to the Union's objectives on climate mitigation, competitiveness and sustainable product policy as well as to the need to move from the existing labelling scheme to a new dynamic labelling classification.
- However, it is largely admitted that the current energy classes definitions do not allow to show the best performing products in their categories.
- Moreover, as there is hardly 0.5% – 1% of A-rated tumble dryers, it can be argued that the label has not been as efficient for tumble dryers as it has been for cold appliances or washing machines.
- Another issue which was raised by stakeholders during the consultation is the tolerance values. It is stated that the 15% limit is too high and allows products to reach a higher energy class than they should (the related issues are detailed for example in MTP (2008)¹⁴⁴).
- Finally, there were also claims that compliance enforcement is not stringent enough in most Member States. On the subject, several studies were carried out, notably by the MTP (2006)¹⁴⁵ and ANEC¹⁴⁶.
- The consultation also addresses the question of the relevance of displaying additional information on the label: information on the global performance of EuPs not restricted to energy efficiency and in particular adding CO₂, as well as adding annual running costs. None of these proposals received much support, as they would either require a significant amount of preparatory methodology work (for an “ecodesign” label accounting for LCA impacts) or would encounter practical difficulties for defining reliable and meaningful values for EU27 (e.g. the CO₂ impact depends on national energy production mixes, it would be difficult to define a price for energy within liberalised markets, etc.).

Ecolabels

None of the most common “eco-labels” deals with clothes dryers. In fact, in Europe, neither the Ecolabel nor the Energy star systems exist for laundry dryers. According to European industrial sources, the European Eco-label is unlikely to do so in the near future: it is assumed that consumers would not perceive (and therefore would not be willing to pay for) the value of environmentally superior performance in dryers. The U.S. Department of Energy (DoE) justifies the absence of an Energy Star label for clothes dryers based on the results of a detailed study conducted by the DoE's Appliance Standards Program which shows that most dryers on the US market have a similar energy consumption: even though they are energy intensive, the lack of differentiation fails to justify the needs for this comparative label. This is also the reason why the Federal Trade Commission (FTC) does not require clothes dryers to have a yellow Energy Guide label¹⁴⁷. Over the next few years, the DoE Appliance Standards Program will be revisiting this study as it determines to see if changes in technology and market conditions make an Energy Star clothes dryers program more feasible.

¹⁴⁴ MTP (2008)

¹⁴⁵ MTP (2006)

¹⁴⁶ ANEC (2007)

¹⁴⁷ The yellow EnergyGuide label, familiar to most appliance shoppers in the U.S., helps consumers compare the operating costs of competing models and aids them in identifying high-efficiency models that will reduce their energy use.

Other Endorsement labels

In the United Kingdom, the energy saving recommended (ESR) label was elaborated by the Energy Saving Trust (EST), highlights products that demonstrate best practice in terms of energy efficiency, thus allowing consumers to identify products that consume less energy more easily. The criteria are set so as to award the label to the top 20% energy efficient products, using the energy efficiency classes set in the EU Energy Labelling implementing Directives as indicators. In February 2007, a category for gas-fired domestic tumble dryers was established as part of the ESR scheme (see details in Annexe of Task 1).

In other countries, such as Australia, an award system has been put in place.

That is the case for the Top energy saver award winner (TESAW), a new award system (launched in 2004), that Australian and State governments along with the appliance industry have created to recognise the most energy efficient (best in class) star rated products on the market. It is complementary to the mandatory comparative star rating label. It applies to both electric and gas products that carry a star rating energy label but there are separate TESAW labels for electric and gas appliances (cf. Annexe of Task 1).

As a conclusion, endorsement labels focus on energy consumption criteria, as do mandatory comparative energy labels. Indeed, the most impacting phase regarding environmental issues is the use phase where energy consumption is the main contributing indicator, as already discussed in Task 7 and according to many of the respondents during the consultation process for the revision of the Energy Labelling framework Directive.

Voluntary initiatives

Concerning voluntary initiatives, there is only a little percentage of existing ones which consider clothes dryers in their scope, and none within Europe. This seems to stem from the idea that clothes dryers are energy intensive appliances which use should be avoided altogether. This is what gives them a low priority on such schemes.

Furthermore, nearly all voluntary initiatives considering clothes dryers deal exclusively with energy labelling and fail to address other aspects of the environmental performance. The only exception is the Taiwanese Greenmark label. This program, launched in 1992, was developed to promote the concept of recycling, pollution reduction, and resource conservation. The objectives of awarding the Green Mark is to guide consumers during their product purchasing process and to encourage manufacturers to design and supply products with better global environmental performances. For electric clothes dryers, specific criteria and requirements concerning plastic components for example (cf. Annexes of Task 1).

Finally, no industry voluntary commitment is in place for laundry dryers in Europe whereas there is one for washing machines for example.

Financial policy instruments

During this study, we did not identify any financial policy instrument (incentive ad/or taxation) worldwide in order to foster the use and/or the production of more energy efficient laundry dryers.

At this stage, we should remind the general scope of the main financial policy instruments that could be considered to promote energy efficient appliances, those instruments include economic and fiscal incentives.

Economic incentives include the following:

- Investment subsidies, through fixed amount, percentage of the investment (up to a limit), or sum of money proportional to the amount of energy saved given to consumers (most common) to lower the purchase cost of energy efficient equipment or to producers (less frequent) to improve the quality and reduce the cost of production, thus creating a larger market than would exist otherwise, encouraging the development and marketing of energy efficient equipment, with the objective of a cost reduction for the subsidized energy efficient equipment,
- Soft loans offered at subsidised interest rates (i.e. lower than the market rate) to consumers (most common) who invest in energy efficient technologies and equipment or given directly to installers (less frequent) which, if well managed, remove one important barrier: the access of consumers to information, as the installers may have a commercial approach to promote energy efficiency.

Fiscal incentives include the following:

- Taxation may be used to help correct market imperfections (e.g., taxation of energy use) by forcing better internalization of the costs of particular behaviours,
- Accelerated depreciation (industry/ commercial sector), which means an authorization for businesses to more rapidly depreciate the costs of their investments in EE technologies (thus reducing their taxable income compared to normal depreciation during the depreciable life of the equipment purchased): the reduced tax burden effectively reduces the cost of the equipment, making it a more attractive investment option,
- Tax deductions, which are deductions of some or all of the cost of investment in energy efficiency technologies from the annual profits. The savings are equivalent to the amount of tax which would have been paid on the amount of the deduction. They can also be designed for companies that make concrete commitments to energy efficiency gains / CO2 reduction and meet their target,
- Tax reductions, reduction of taxes paid on the purchase of energy efficiency equipment, such as VAT or import duties,
- Tax credits, reduction of the total tax liability by some or all of the cost of an investment in energy efficiency.

Information programmes

We did not identify specific information programmes considering the use of laundry dryers in order to foster energy efficient behaviours of the customers. Manufacturers use traditional means of communication mainly through their company website or product sheet.

It shall be noted that apart from information programme on the use of the appliances, some NGOs such as Topten developed comparative web-based tools to assist the customer in the choice of the most performing appliances in terms of environmental impacts. Laundry dryers are included in this analysis.

VIII.2 Policy measures considered

VIII.2.1 Minimum Energy Performance Standards (MEPS)

MEPS are usually used to phase out the most inefficient appliances within a product category. Currently there are no MEPS in Europe for tumble dryers.

According to the findings of Task 2, the repartition of sales in 2005 was as follows:

Table 145: Sales distribution by energy efficiency classes in 2005

Energy efficiency class	Sales (units) 2005	Sales (percentage) 2005
A	17 135	0.5%
B	17 834	0.5%
C	3 325 417	89.7%
D	213 803	5.8%
E	12 799	0.4%
F	93 461	2.5%
G	1 374	0.04%
UNKNOWN	24 929	0.7%

If all appliances sold in 2005 were in energy efficiency classes equal or above class C, electricity consumption savings over their lifecycle would have amounted to approximately 1.6 TWh¹⁴⁸.

It should be noted that exceptions are considered for compact dryers because they are inherently less efficient than their bigger size counterpart, but they represent a small market and target specific users with specific needs (e.g. due to lack of space, one person households, etc.).

VIII.2.2 Labels

Mandatory comparative EU Energy label

The mandatory comparative European energy label is currently the main pillar of the European strategy for improving the energy efficiency of tumble dryers. However, so far, the energy label has not been optimally effective in shifting the energy performance of dryers on the markets. There may be a number of reasons for that.

First, until recently, most dryers on the market had rather similar energy consumptions, thus the label could not influence the purchasing choice of consumers.

Moreover, now that there are e.g. heat pump dryers which may save up to 50 % energy consumption compared to average ones (class C), the energy classes as they are defined do not allow consumers to perceive the actual gap between these dryers (class A) and those achieving current class B (up to 40 % difference in energy consumption). Since A-rated tumble dryers are currently significantly more expensive than others,

¹⁴⁸ Calculated using the current definition of energy efficiency classes, and relative to the functional unit of this study, i.e. drying the linen of an average European household during one year.

consumers would need to perceive a major difference in the energy performance for their choice to be influenced by the label.

Adding to this, since gas dryers are not covered by the current energy label, the label could not provide information to consumers who willing to buy such dryers (in particular in countries where gas infrastructures are well developed and gas-fired appliances are more widespread).

A more general issue related to dryers, otherwise confirmed by the absence of ecolabels and the low number of other labels which include them in their scope, is that they are usually considered as energy gazzling appliances which use should be avoided altogether. Thus, there is a lack of awareness raising and relay of information (for example supported by environmental organisations) when it comes to laundry dryers: the impact of the label can thus be considered lowered by the lack of synergies with other information schemes compared to other appliances.

During the consultation processes for the Energy Labelling Directive revision and for this study, several detailed proposals have been made concerning improvements for the energy label in general and for the tumble dryers' label in particular. They are presented in details in Annexe. W and X

Endorsement labels

Ecolabel

As presented in Task 5, energy consumption during use phase is the most relevant environmental impact, therefore the cost effectiveness of the development of a specific ecolabel for laundry dryers is questionable since the energy consumption criteria is already tackled with the energy labelling scheme.

Other Endorsement labels

Other endorsement labels, such as ESR in the UK, can make it easier for consumers to identify best energy efficient products for consumers. Nevertheless, the regulatory authorities already play a significant part in the definition and implementation of the mandatory energy labelling scheme. Therefore, other types of endorsement labels could be kept to voluntary initiative of the private sector (or such as the TESAW label in Australia).

VIII.2.3 Voluntary initiatives

At the European level, CECED developed 5 existing voluntary agreements, including one on washing machines. Laundry dryers have never been included in this type of scheme and it is unlikely that any industrial voluntary agreement can be concluded in the future for laundry dryers. Indeed, Ceced argues for legislative measures to ensure future energy performance standards as an alternative to continued updating of the voluntary agreements that industry introduces a decade ago. In 2007, Marcus Yngen from Electrolux and also Ceced president, expressed the need "for the next round of improvements, to be driven by legislation that applies to all and is enforced on all". There is therefore a clear demand from industrials for regulation.

It should be reminded that such industry initiatives permitted significant improvements in terms of carbon reduction (those programmes estimated to have cut 17 million tons of CO₂ from Europe's emissions up to 2007) but industrials often claimed that fair competition is not guaranteed by authorities that should prevent "free riding behaviours".

VIII.2.4 Financial incentives

Regarding the different instruments described in paragraph VIII.1.1, CECED¹⁴⁹ considers them as market-based instruments to "get the prices right" (taxation or incentives) which

¹⁴⁹ CECED's input to the European Commission's Green Paper on market-based instruments for environment and energy related policy purposes.

can play a fundamental role in improving the consumer uptake of highly environmentally friendly technologies/goods. For CECED, tax credits to consumers or manufacturers are the best instruments and policies that should be avoided are those that alter the consumers' perception of the value of goods, such as reduced VAT rates for efficient energy using products.

In lot 14, it is assumed that production tax credits are most cost effective for governments with respect to rebates and lower value added taxes, mainly for two reasons:

- The production tax credits are based upon tax credits for only those units produced above an established level of production and sales instead of assuming a rebate scheme for all appliances for example,
- The grant is used to lower the price at the production stage what has a greater impact on retail prices because of the high mark-up of distributor and retailers.

Nevertheless, as already discussed in Lot 14, even if delivering direct subsidies to manufacturers can be more cost effective, this option presents two main complications linked with the respect of the rule regarding state aid regulation and the need to design a fair funding mechanism between net importer and exporter countries.

Information programmes

The study of consumer behaviour in task 3 showed the strong influence of the user's practices (in terms of operation, regarding the loading of the machine, for example) on the energy efficiency of domestic laundry dryers. Edit guides/leaflets with examples of good practices to improve the use of the machine could be a good alternative to raise awareness of consumers. Indeed, we have noted in our survey in Task 3 that information regarding environmental issues is mainly communicated by manufacturers through the user manual, the point of sale and sales people, the company website and the product sheet. Provide more concrete examples of savings on running costs and on the way to improve the energy performance of the laundry dryer should be relevant complementary instruments to train consumers.

VIII.3 Scenario analysis

Four scenarios allow to quantify the improvement that can be achieved thanks to policy measures in the period 2005-2020 for the EU27 compared to a reference scenario:

- The “Business as usual” scenario: is the reference scenario. It takes into account current short term trends in terms of product design and market uptake, as well as the continuation of the current policy measures underway (see VIII.1.2).
- The “Conservative” scenario: is a scenario which accounts for pursuing with the current label and introducing MEPS banning the least efficient products from the market, namely here those under current class C.
- The “BAT – Moderate” scenario: is a scenario which accounts for the combination of introducing MEPS and a new label, combined with subsidies for encouraging the uptake of best available technologies, having a moderate impact.
- The “BAT - Ambitious” scenario: is a scenario which accounts for the same measures as in the BAT- Moderate scenario, but considering more aggressive subsidies and more ambitious overall results.

For each of these scenarios, the following indicators are studied:

- Electricity consumption of the stock of products during the use phase (TEC, in TWh)
- Primary energy consumption of the stock of products (GER, in PJ)
- Global warming potential of the stock of products (GWP100, in mtCO₂eq¹⁵⁰.)
- Energy costs to consumers (in million euros)

Similarly to EcoReport total EU impacts calculations, and in order to assess the impacts related to the functional unit (here: drying the linen of an average European household during one year), the impacts in terms of total primary energy consumption and global warming potential are spread over the life cycle of the products (e.g. for a given year, the primary energy consumption considered is the total primary energy consumption over the life cycle of the product divided by the lifetime of the product).

VIII.3.1 General hypotheses

The main common hypotheses, used in all scenarios, are the following:

General costs assumptions

- Electricity price: 0.17 €/kWh.
This is consistent with Lot 14 (washing machines) and Task 2 of this report. The electricity price is assumed to be constant in the future. This is a simplifying assumption, as the price is likely to evolve due to several factors (including market forces and other external factors).
- Gas price: 13.02 €/MJ.
The gas price is assumed to be constant in the future. Again, this is a simplifying assumption, as the price is likely to evolve due to several factors (including market forces and other external factors).

A sensitivity analysis on electricity and gas prices is carried out in VIII.5.2.

¹⁵⁰ Metric tonnes of carbon dioxide equivalent

Use scenario assumptions

- Standard conditions
- Quantity of linen dried per year and per household: 528 kg
- The dryer is used in its on-mode to dry the linen, in a low consumption mode where the on-button is engaged for 250 h (2.5 W) but does not dry and in off-mode for the rest of the time (0.01 W)

Characterization of products: main environmental characteristics and costs

Base Cases (Task 5)

		Base case air vented dryer	Base case condenser dryer
Energy consumption in use	kWh/cycle	3.36	3.60
Annual electricity consumption	kWh/year	297	318
Annual primary energy consumption	MJ/year	3 293	3 559
Annual GWP 100	kgCO ₂ eq.	148	161
Purchase price	€/year	380	547
Annual electricity costs	€/year	50	54
Annual maintenance & repair costs	€/year	5.5	5.5
Lifetime	years	13	13

Improved products (Task 6)

		Base case air vented dryer	Base case condenser dryer
Energy consumption in use	kWh/cycle (elec)	0.37	2.00
	kWh/cycle (gas)	3.65	0
Annual electricity consumption	kWh/year	34	177
Annual primary energy consumption	MJ/year	1 806	2 152
Annual GWP 100	kgCO ₂ eq.	101	101
Purchase price	€/year	730	877
Annual electricity costs	€/year	21	30
Annual maintenance & repair costs	€/year	5.5	5.5
Lifetime	years	13	13

Least performing products

		Base case air vented dryer	Base case condenser dryer
Energy consumption in use ¹⁵¹	kWh/cycle	4.11	4.66
Annual electricity consumption	kWh/year	363	411
Annual primary energy consumption	MJ/year	3 977	4 538
Annual GWP 100	kgCO ₂ eq.	178	203
Annual electricity costs	€/year	62	70
Annual maintenance & repair costs	€/year	5.5	5.5
Lifetime	years	4.11	4.66

Sales and stock

The parameters for the stock and sales model (cf. Task 2) are reminded below:

- Total market size (number of European households)
- Ownership penetration rate (household equipment rate): assumed to reach saturation at 36 % by 2010
- Average product life
- Waste curve
- Repartition between air vented and condenser dryers

Note that the time step considered is 5 years, thus the sales provided e.g. for 2005 are for the 5 previous years, i.e. 2000-2005.

Table 146: Hypotheses on stocks and sales repartition between air vented and condenser dryers

	Stock		Sales			
	Vented dryers stock (million units)	Condenser dryers stock (million units)	Western sales (million units)	Eastern sales (million units)	Vented dryers sales (%)	Condenser dryers sales (%)
1975	2.3	0.0	2.3	0.0	100%	0%
1980	7.3	0.0	5.0	0.0	100%	0%
1985	13.0	0.0	5.7	0.0	100%	0%
1990	18.7	3.4	11.2	0.0	70%	30%
1995	22.8	9.3	14.7	0.0	60%	40%
2000	24.5	16.6	14.8	0.1	50%	50%
2005	27.5	26.4	23.4	0.1	45%	55%
2010	27.7	34.1	21.1	1.1	40%	60%
2015	27.5	40.6	19.8	1.6	35%	65%
2020	26.1	48.6	27.2	1.8	30%	70%

In order to account for the introduction of MEPS, we had to refine the model from the VHK methodology so that it would not only allow a share of improved products to replace the stock of dryers, but would also account for a share of least performing products to be

¹⁵¹ This is a weighted average of the lower ends of the current energy efficiency classes under C, by sales in 2005

eliminated. However, due to the lack of historical data (energy classes for tumble dryers were not introduced before 1995 and thus no record of sales by energy classes are available), and in order to provide a level playing field compared to other products studies where these products are not taken into account, we model the worst performing products only for 2000-2020. In practice, this means that the absolute impacts of the stock may be slightly underestimated. The savings, however, remain the same since the same difference applies to all scenarios.

VIII.3.2 Scenario-specific hypotheses

Business as usual scenario

This scenario serves as the reference for comparing the other scenarios. It allows to evaluate the potential impact of tumble dryers sold and in stock on the European market in the case that no new measures were introduced, assuming all other things remain equal.

The assumed sales are provided in Table 147.

Table 147: Sales hypotheses for BaU scenario

	BC vented	BAT vented	<class C vented	BC condenser	BAT condenser	<class C condenser
	(million unit)	(million unit)	(million unit)	(million unit)	(million unit)	(million unit)
2005	9.43	0.05	1.10	11.76	0.07	1.10
2010	7.92	0.09	0.87	12.12	0.13	1.07
2015	6.70	0.15	0.66	12.68	0.28	0.98
2020	7.76	0.44	0.51	18.47	1.02	0.82

Conservative scenario

This scenario accounts for conventional measures. Here, we model the effect of pursuing with the current label and introducing MEPS banning the least performing products from the market by 2010, defined as those achieving a lower energy efficiency class than class C under the current label. They represented c.a. 10 % of the annual sales in 2005.

The assumed sales are provided in Table 148.

Table 148: Sales hypotheses for the Conservative Scenario

	BC vented	BAT vented	<class C vented	BC condenser	BAT condenser	<class C condenser
	(million unit)	(million unit)	(million unit)	(million unit)	(million unit)	(million unit)
2005	9.43	0.05	1.10	11.76	0.07	1.10
2010	8.79	0.09	0.00	13.19	0.13	0.00
2015	7.36	0.15	0.00	13.67	0.28	0.00
2020	8.27	0.44	0.00	19.29	1.02	0.00

BAT – Moderate scenario

This scenario considers the effects of introducing MEPS as defined in the conservative scenario, updating the energy label (energy efficiency class definition and/or possibly introducing gas dryers in its scope) combined with subsidies in some Member States, having a moderate impact. The hypotheses correspond to assuming that:

- gas dryers reach 10 % of air vented dryers' sales by 2015 and 20 % by 2020 in specific Member States where gas appliances are more widespread and where subsidies would thus be more efficient (e.g. the UK and the Benelux, which amount to c.a. 40 % of the tumble dryers' market in 2005)
- heat pump dryers reach the same shares of condenser dryers' sales in the other Member States.

Table 149: Sales hypotheses for the BAT-Moderate Scenario

	BC vented (million unit)	BAT vented (million unit)	<class C vented (million unit)	BC condenser (million unit)	BAT condenser (million unit)	<class C condenser (million unit)
2005	9.43	0.05	1.10	11.76	0.07	1.10
2010	8.66	0.22	0.00	13.10	0.22	0.00
2015	6.67	0.84	0.00	12.64	1.31	0.00
2020	6.43	2.27	0.00	16.77	3.53	0.00

Considering that subsidies allow to make the appliance cost-effective over its life cycle (i.e. 153 euros for a gas vented dryer and 47 euros for a heat pump dryer), and that the subsidies may account for half to all of the increase in sales compared to the base case scenario, the range of subsidies necessary is :

Table 150: Estimation of range of subsidies for the BAT-Moderate Scenario

	Subsidies for gas dryers (Million euros)	Subsidies for HP dryers (Million euros)	Total (Million euros)
2 010	10-20	3-6	13-27
2 015	53-106	16-33	69-138
2 020	141-281	43-87	184-368

This does not take into account the effect of market transformation on the price of the appliances.

BAT - Ambitious scenario

This scenario considers the effects of updating the label (energy efficiency class definition and/or possibly introducing gas dryers in its scope), combined with large subsidies in some Member States, having a significant impact.

This scenario is ambitious in the sense that not only would it require to change sensibly consumer purchasing behaviour but it would also imply major changes in both infrastructures (e.g. for gas) and production capacities (increase of factory lines producing heat pump and gas dryers). Indeed, it corresponds to assuming that:

- gas dryers reach 30 % of air vented dryers' sales by 2015 and 50 % by 2020 in specific Member States where gas appliances are more widespread and where subsidies would thus be more efficient (e.g. the UK and the Benelux, which amount to c.a. 40% of the tumble dryers' market in 2005)
- heat pump dryers reach 40 % of condenser dryers' sales by 2015 and 80 % by 2020 in the other Member States.

Table 151: Sales hypotheses for the BAT-Ambitious Scenario

	BC vented	BAT vented	<class C vented	BC condenser	BAT condenser	<class C condenser
	(million unit)	(million unit)	(million unit)	(million unit)	(million unit)	(million unit)
2005	9.43	0.05	1.10	11.76	0.07	1.10
2010	8.66	0.22	0.00	13.10	0.22	0.00
2015	4.99	2.52	0.00	8.72	5.23	0.00
2020	3.03	5.67	0.00	6.17	14.13	0.00

Considering that subsidies allow to make the appliance cost-effective in 4 years (i.e. 266 euros for a gas vented dryer and 210 euros for a heat pump dryer), and that the subsidies may account for half to all of the increase in sales compared to the base case scenario, the range of subsidies necessary is :

Table 152: Estimation of range of subsidies for the BAT- Ambitious Scenario

	Subsidies for gas dryers (Million euros)	Subsidies for HP dryers (Million euros)	Total (Million euros)
2 010	18-35	14-28	32-63
2 015	315-630	248-496	563-1 126
2 020	697-1 394	549-1 097	1 246-2 492

This does not take into account the effect of market transformation on the price of the appliances.

VIII.3.3 Scenario analysis

The following figures illustrate the potential savings in each scenario. All detailed figures are available in Annexe W and X.

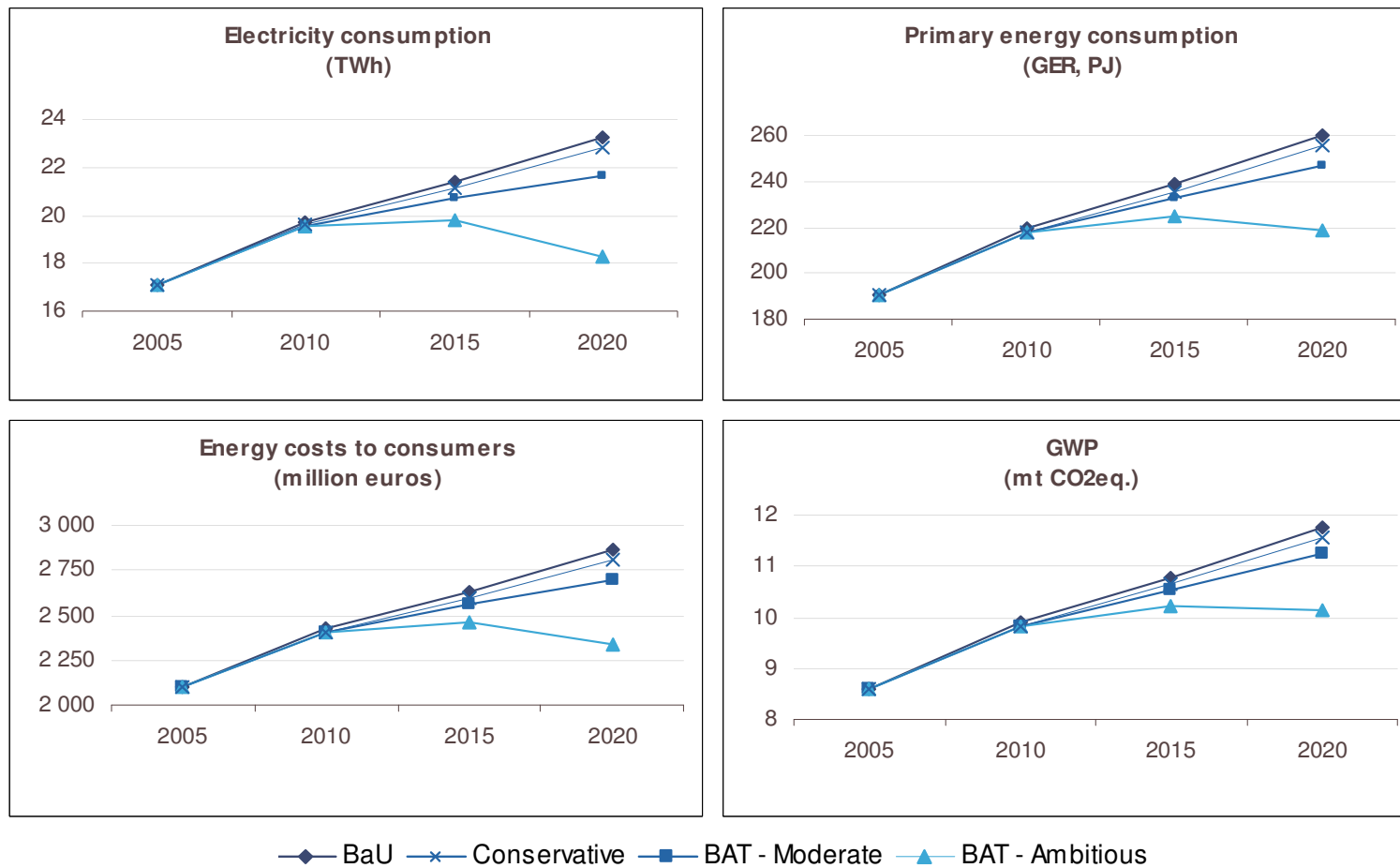

Figure 203: Scenario analysis

The following analysis is made on the basis of the detailed results provided in Annexe.Y
The figures are rounded.

Electricity

- Under the BaU scenario, the annual electricity consumption increases by 15% by 2010, 25% by 2015 up to 36% by 2020 compared to 2005.
- The Conservative scenario would allow saving (annually) 0.2 TWh by 2010 to 0.3 TWh by 2015 and 0.4 TWh by 2020.
- The BAT – Moderate scenario would translate into savings of 0.7 TWh by 2015 up to 1.6 TWh by 2020.
- The BAT – Ambitious scenario would mean savings of 2 TWh by 2015 to 5 TWh by 2020.

To put these figures in perspective: the total electricity consumption in the residential sector for the EU-25 represented 765 TWh (28.8% of the total electricity consumption).

Primary energy

- The savings from the Conservative scenario would amount to 2 PJ by 2010 to 3 PJ by 2015 and 4 PJ by 2020.
- The BAT – Moderate scenario would represent 2 PJ of primary energy saved annually by 2010 up to 6 PJ by 2015 and 13 PJ by 2020.
- The BAT – Ambitious scenario would allow to reach annual savings of 14 PJ by 2015 to 41 PJ by 2020.

Greenhouse gas emissions

- The avoided greenhouse gas emissions from the Conservative scenario would amount to 0.1 mtCO₂eq by 2010 to 0.2 mtCO₂eq by 2020.
- The BAT – Moderate scenario would result in 0.2 mtCO₂eq of greenhouse gas emissions avoided by 2015 to 0.5 mtCO₂eq by 2020.
- The BAT – Ambitious scenario would translate into emission savings of 0.6 mtCO₂eq by 2015 up to 1.6 mtCO₂eq by 2020.

Costs to consumers

- The energy costs savings to European consumers from the Conservative scenario would amount to 19 million euros by 2010 to 49 million euros by 2020.
- The BAT – Moderate scenario would mean savings of 24 million euros by 2010, 79 million euros by 2015 up to 168 millions by 2020.
- The BAT – Ambitious scenario would allow European consumers to save 176 million euros by 2015 up to 527 millions by 2020.

VIII.4 Impact on manufacturers and consumers

VIII.4.1 Impact on manufacturers

For the calculations in Task 7 it is assumed that the additional product costs are passed on one-to-one to the customer. It is also implicitly assumed that the additional costs are the same or similar for all manufacturers of the same product type. In principle, additional costs then affect all products in the same way, thus competition is not disturbed.

Nevertheless, in practice, setting ecodesign requirements through various types of policy instruments can have potential impacts on manufacturers. Some identified impacts include¹⁵²:

- Products may have to be redesigned to achieve the improvements. If the adjustments can be made during a regular redesign cycle the additional design costs are not very high, but early, unscheduled redesigns could lead to additional costs. As the status and regularity of redesigns varies a lot between companies, some manufacturers could be more affected than others.
- Another important issue for manufacturers could be the capital investment needed to upgrade their production platforms, happening before the end-of-life of the production platform (typical life time is estimated to 15 to 20 years),
- Redesign could also affect the product quality and reliability for a short period of time. This could increase warranty costs to manufacturers.

Those potential impacts should be studied in more details in future impact assessment studies regarding policy options for ecodesign of laundry dryers.

VIII.4.2 Impact on consumers

From the consumers point of view, and in a lifecycle perspective, if the life cycle costs are reduced, there is no negative impact on the customer.

Nevertheless, we can assume that some problems might appear for consumers. First, as presented in Task 7, few improvement options are currently cost effective in the case of laundry dryers. Indeed, the cost effectiveness depends mainly on the additional costs considered for new technologies, especially in the case of heat pump dryers. However, these costs could be reduced with increased sales volumes resulting from effective market transformation or in a context where energy prices become higher (see sensitivity analysis).

On another hand, long payback times are more difficult to understand and to accept by consumers. In task 3, we showed through the survey we performed that the expected payback time for consumers was around 2 years (for 48% of the respondents) and that most consumers will not pay an extra price for a lower consumption dryer, unless it pays back in 2-3 years.

Finally, another issue, already presented in Task 6, is the temporary problem during the introduction of such measures because not all consumers can oversee the life cycle costs of a product at the time of the purchase. Therefore, a manufacturer modifying his products ahead of schedule could be disadvantaged during the transition period, if his product costs are indeed higher. Without additional information this could lead, especially in the low price segment where already small differences in the price are important, to a decision towards the less efficient products.

¹⁵² Some elements are quoted from Lot 6

VIII.5 Sensitivity analysis of main parameters

Sensitivity analyses have been carried out on the main relevant parameters of the study. The principle of this analysis is to recalculate the main results after having one of the critical parameters vary. This allows to test the robustness of the assumptions made in the framework of this study and the corresponding results.

VIII.5.1 Local systems

As discussed in task 4, the following parameters have an influence relating to local systems on the energy demand:

- Laundry care chain: spin speed of the washing machine and loading of the dryer
- Ambient conditions: air humidity and temperature
- System boundaries: inclusion of the room (space heating demand)

Spin speed of the washing machine

The spin speed of the washing machine has a significant influence on the energy demand of the laundry dryer. The more efficiently clothes have been spun, the smaller the energy needed to dry out the remaining water. Using a spin speed of 1400 rpm instead of 800 rpm, could lead to a 26% cut in energy consumption during the drying process.

Loading of the dryer

Under a capacity of 5 kg, it is generally accepted that the larger the capacity, the better the efficiency. For a load above 5 kg, the energy consumption becomes steadier. Moreover, it was highlighted in task 5 that using a dryer at its maximum load leads to a lower energy consumption. Indeed, a difference of 5% in energy consumption has been observed between real life base case and standard base case.

Ambient conditions: temperature and humidity

The energy consumption for air vented dryers has a strong dependency on external conditions: it can range from 2.1 kWh/cycle in a best case scenario to 6.13 kWh/cycle in a scenario with low temperature and high humidity (the performance of air vented dryers is then worse than that of condenser dryers). The energy consumption of air vented dryers is much higher if used in a heated room with an open window and inhomogeneous temperature repartition than if used in a heated room with homogeneous temperature

VIII.5.2 Assumptions on costs

A sensitivity analysis has been carried out on the cost assumptions made regarding the estimated projected cost of two critical parameters directly impacting consumers: the energy cost (electricity, natural gas) and the dryer purchase price. In each case, both the payback time (number of years before the extra cost of the BAT device is compensated by the corresponding energy savings) and the life cycle cost (LCC) have been estimated based on different values for the studied parameters.

Energy Prices

Table 153: Sensitivity analysis on energy prices

	min	sales weighted average	current hyp	max
Electricity price (euros/kWh)	0.07	0.14	0.17	0.24
Gas price (euros/GJ)	4.63	13.19	13.02	29.82

In this section, we assume an electricity price ranging:

- from a minimum of 0.07
- to a maximum of 0.24 euros/kWh (minimum and maximum from European countries in 2006, cf. Task 2),

and a natural gas price ranging:

- from a minimum of 4.63
- to a maximum of 29.82 euros/GJ (see values below).

Two intermediate scenarios are explored as well:

- the current hypothesis scenario corresponds to the values chosen for lot 14,
- the sales weighted average scenario, which corresponds to an averaged value based on 2006 data on energy prices in the countries where the laundry dryer sales are highest (UK, France, Germany, Benelux, Denmark, Sweden, Spain) weighted by the sales in these countries.

Table 154: Sensitivity analysis on energy costs: payback time and LCC

	Payback time (years)				LCC (euros)			
	min	sales-weighted average	current hyp.	max	min	sales-weighted average	current hyp.	max
Vented Base Case					628	821	906	1 091
Condenser Base Case					808	1 015	1 106	1 304
Vented BAT (Gas dryers)	26.7	16.3	11.8	12.7	855	970	978	1 181
Condenser BAT (HP dryers)	33.4	16.8	13.8	9.9	1 045	1 160	1 211	1 321

There is a significant difference in the payback time for condenser dryers depending on the assumptions made on energy costs. In the case of high costs, the payback time is estimated to come as low as 9.9 years for BAT condenser dryers (compared to 13.8 years under the current hypotheses). However, for vented dryers, since the high price of gas lowers the energy costs savings compared to the base case which consumes only electricity, the payback is longer (12.7 years compared to 11.8 years).

Note that in our estimation for BAT, although the computed payback time is smaller than the life span of the dryers (13 years), the life cycle cost is higher than for BC. This is due

to the fact that the presented LCC consider the real costs (discounted), whereas the payback times have not been adjusted in order to take into account the time-value of money (such adjustment would increase the payback time by a factor of 1.38).

Additional Costs / purchase price

Table 155: Sensitivity analysis on additional costs

Cost increase (euros)	min	current hyp	max
Gas dryers	200	350	500
HP dryers	300	330	360

Resulting purchase price (euros)	min	current hyp	max
Gas dryers	580	730	880
HP dryers	847	877	907

In this section we assume an additional cost varying from 200 to 500 euros (i.e purchase price ranging from 580 to 880 euros, compared to the current hypothesis: 730 euros) for gas dryers and 300 to 360 euros for HP dryers (i.e purchase price ranging from 847 to 907 euros, compared to the current hypothesis: 877 euros). This corresponds to the ranges found in Task 6 when improvement options were identified

Table 156: Sensitivity analysis on additional costs: payback time and LCC

	Payback time (years)			LCC (euros)		
	min	current hyp.	max	min	current hyp.	max
Vented Base Case				906	906	906
Condenser Base Case				1 106	1 106	1 106
Vented BAT (Gas dryers)	6.74	11.79	16.85	828	978	1 128
Condenser BAT (HP dryers)	12.53	13.79	15.04	1 181	1 211	1 241

As can be expected, the lower the additional cost, the lower the LCC for the BAT. For the selected range of costs:

- For vented dryers: the LCC savings when shifting from BC to BAT goes from 78€ (net benefit when replacing the BC by the BAT) to -222 € (extra money is required for the BAT compared to the BC)
- For condenser dryers the LCC savings when shifting from BC to BAT is always negative: an extra 75 to 135 € has to be paid for the BAT.

Since the BAT option for condenser dryers was not found to be cost effective under current assumptions, an additional calculation was carried out to find out the balance point.

On the basis of the current situation (electricity price of 0.17 €/kWh, gas price of 13.02 €/GJ and purchase prices assumed), the price of electricity and the purchase price for

which entail equal life cycle costs for the BAT and the BC have thus been computed (i.e. the electricity savings of the BAT compensate its additional purchase price over the lifetime of the appliance). Results are shown in the following table.

Table 157: Cost effectiveness tipping point

Parameter adjusted	Vented	Condenser
Electricity price (€/kWh)	0.20 (+18%)	0.25 (+47%)

Parameter adjusted	Vented	Condenser
Additional costs (euros)	279	225
Purchase price (euros)	659 (+14%)	772 (+41%)

The underlying principle of this calculation is that, in a limited period of time (the lifetime of the dryer):

- when energy costs go up, the BAT allows to cut down energy expenses during the life of the dryer, which eventually compensates the higher upfront investment of buying it.
- when the purchase price is lower, less energy costs savings are required to compensate the incremental cost.

It should be noted that this notion cannot be applied to exploring which gas price would equal out the LCC of the BAT and BC for vented dryers: indeed, the BAT uses natural gas whereas the BC does not (solving for a gas price that would balance the LCC of the BAT and BC would then result in a gas price lower than the current gas price).

VIII.5.3 Assumptions on the penetration rate

In this section, we focus on the sensitivity of the results with respect to the penetration rate (and thus to the European stock of dryers). In all previous results we assumed a penetration rate of 36%. In this specific section we study the impact of a 40% penetration rate on the computed results (see below). The scenarios explored here are the scenarios defined in VIII.3: i.e. the BaU, Conservative, BAT – Moderate and BAT – Ambitious scenarios.

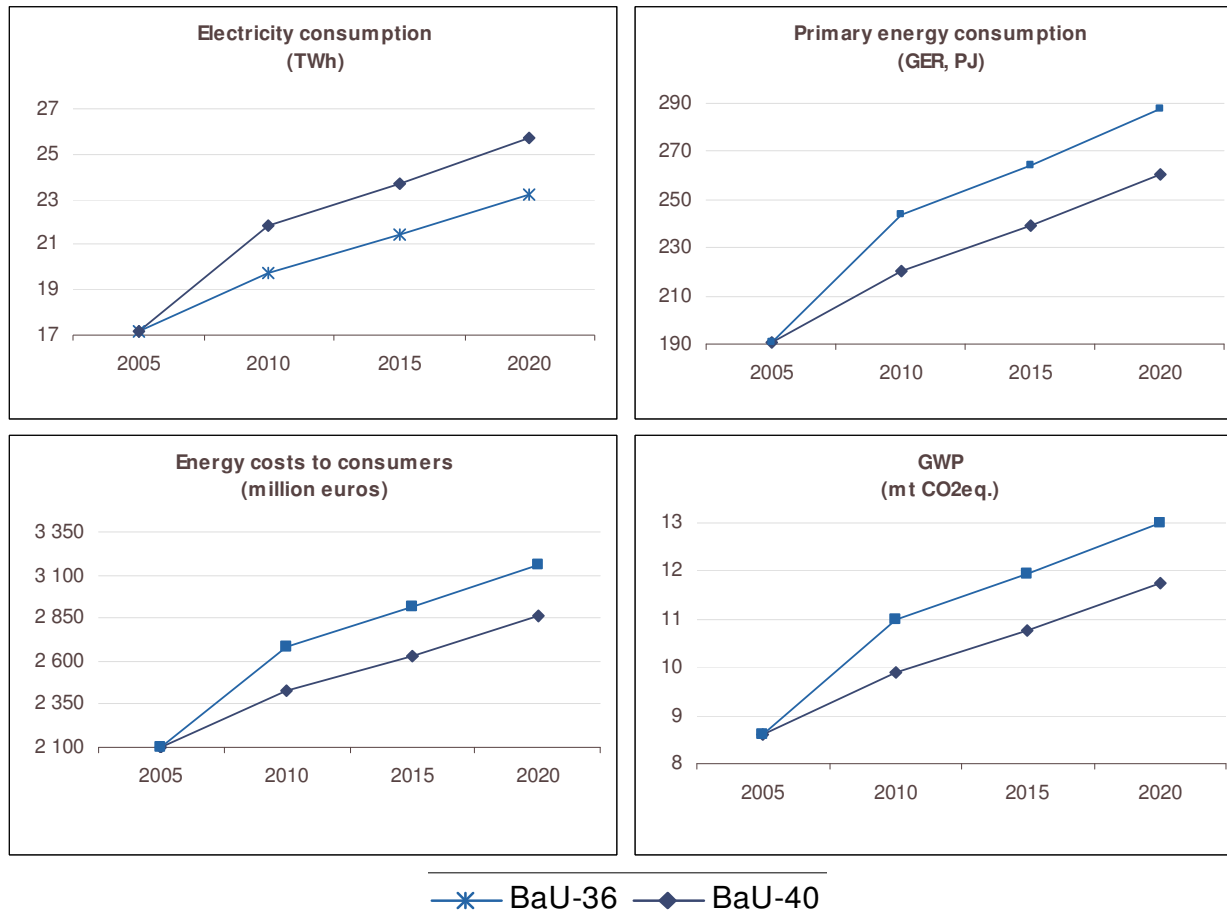

Figure 204: Sensitivity analysis on the penetration rate

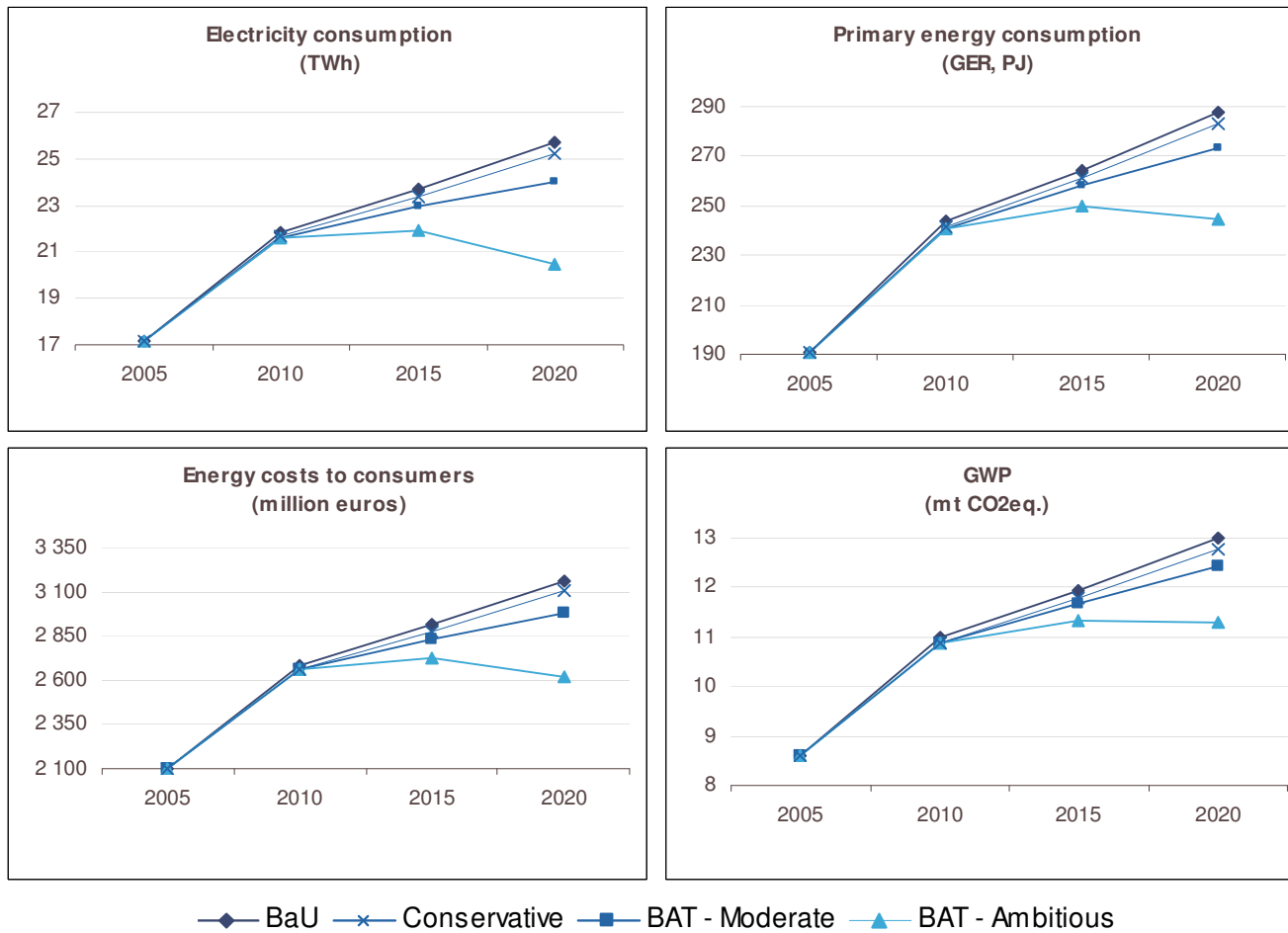

Figure 205: Scenario analysis, assuming a 40 % penetration rate

Electricity consumption

A higher penetration rate logically results in a higher electricity consumption as there are more dryers operated. This increase, however, is smaller when BATs are introduced (since their introduction, and thus the savings they permit, are proportional to the stock): the difference between a 36% and a 40% penetration rate corresponds to an increase in the annual electricity consumption of approximately 2.1 TWh by 2010, 2.3 TWh by 2015 and 2.4 TWh by 2020 for the BaU scenario.

Primary energy consumption

The sensitivity here is similar to that for electricity consumption. The increase in the primary energy consumption under a 40% penetration rate assumption, compared to 36%, amounts approximately to 24 PJ by 2010, 25 PJ by 2015 and 27 PJ by 2020 for the BaU scenario.

Greenhouse gas emissions

Essentially the greenhouse gas emission trends have the same behaviour as the energy trends: the difference between a 36% and a 40% penetration rate corresponds to an increase in the overall GWP of approximately 1.1 mtCO₂eq up to 1.2 mtCO₂eq for the BaU scenario.

Energy costs to consumers

Again, energy costs are linked to the energy consumption in use. A penetration rate of 40% would thus represent more savings since there would be more dryers in use (an extra 260 million euros savings by 2010, 280 millions by 2015 and 301 millions by 2020 in the BaU scenario).

Annexes to Task 8

U References

- ANEC (2007) *A review of the range of activity throughout Member States related to compliance with the EU Energy Label regulations in those countries*, at: [http://www.anec.eu/attachments/ANEC-R&T-2006-ENV-008%20\(final\).pdf](http://www.anec.eu/attachments/ANEC-R&T-2006-ENV-008%20(final).pdf)
- MTP (2008) *Briefing Note BNXS40: Reducing the impact of tolerances within the current EU Energy Labelling scheme*, at: www.mtprog.com/spm/download/document/id/644
- MTP (2006) *Survey of Retailer Compliance with Energy Labelling Requirements 2006*, at: http://www.mtprog.com/spm/files/download/byname/file/Energy%20labelling%20survey%20of%20retailers%20_2006_.pdf
- Rüdener, Gensch, Liu (2008) *Vergleich der Umweltauswirkungen und Kosten verschiedener Wäschetrocknungssysteme*, Öko Institut
- VHK Van Holsteijn en Kemma BV (2005), MEEuP methodology report, Final Report

V Summary of comments from stakeholders

Preliminary comments by technical experts will be included in this document.

W CECED proposal for MEPS and a new tumble dryer label

CECED proposes the following plan for the MEPS (considering the current Energy label Classes):

- First Tier – 2 years after publication – Phase out of class D of standard electric dryers and class E of compact electric dryers
- Second Tier – 6 years after publication – Phase out of class C of standard condenser electric dryers (no further phasing out of vented or compact dryers)

A unique, numeric, open-ended scale

During the consultation on the energy labelling revision, CECED proposed a new layout for the label, in order to turn it into a more dynamically evolving scheme and accommodate the continued improvement of products. They propose that the new energy label be based on the principles defined in the following paragraphs.

Layout and evolution/update process

CECED proposes a new open-ended numeric scale allowing for a gradual upgrade to keep up the competitive pressure and development of energy efficient appliances. The open-ended scale would be conceived so as to allow new higher classes at the top. Every time a certain percentage of products reach the highest category another class would be added at the top of the scale. Current products would be rated from 1 (least efficient products) to 7 (most efficient products). When more efficient models enter the market, a new Class "8" rating would be introduced and Class "1" phased-out, etc. The colouring scheme would shift up, so the best performing products could always be identified by the deepest shade of green, and the least efficient by red, as presented in the following figure.



According to CECED, there are a number of benefits to such a design for the energy label:

- It would allow for continuous updating to the top and phase-out at the bottom.
- The colouring scheme would be kept for continuity with the past label and would ensure "recognition" by consumers.
- The consumer would always be able to identify the best class when looking at the colouring scheme. The consumer will still be encouraged to "buy green" as they will see the products in this category as the products in the top parts of the scale and perception will be that these are the best products, in terms of efficiency.
- The continuous updating will not confuse consumers because a category 7 appliance will always remain in category 7, even if new categories are added at the top.

- The criteria for future categories 8, 9 etc. would be known in advance which would create predictability for business and flexibility for national support policies.
- It would have the potential to be the basis of an international approach to energy efficiency rating and thereby to promote global convergence of appliance efficiency.

Tolerance and responsibilities

According to CECED, tolerance levels can be effectively reduced if each actor is held more fully responsible for the factors that are under his control:

- Companies are in control of the manufacturing of their products and should be held responsible for the factors under their control that determine product performance.
- Manufacturers, however, do not control reliability of testing laboratories or testing procedures. Testing laboratories should, therefore, be held fully responsible for their work and as a general objective the overall performance of testing laboratories should be significantly improved across the EU. An appropriate system should be implemented to ensure the future reliability of laboratory services.

General principles

CECED proposes the following principles to design the energy label for tumble dryers:

- Define a unique energy efficiency index, thus allowing to create a single scale for vented and condenser dryers
- Integrate half load
- Keep the same classes for appliances as in the past to avoid market confusion, under certain conditions:
 - B should be B and 6
 - C should be C and 5
 - To keep the same classes, appliances should have good standby and half load performance (0,8W Off-Mode, 1,5W Left-On-Mode, Energy consumption half load =60% of full load)
- Place HP Dryers in classes 8 and 9
- Integrate the condensation efficiency in the label (for condenser dryers)
- Integrate the drying time in the label
- Design classes so that they are not too narrow on the top (because of higher measurement tolerances for HP dryers)
- Design classes so that the bandwidth are not too high to allow showing off increased efficiency

Specific assumptions

- Number of cycles per year: 160
- The dryer is used during 160 cycles in on-mode, half the rest of the time is supposed to be spent in low-consumption mode ("left-on mode"), and the other half in off-mode.

Programme portfolio

- 3 tests with full load (100% of the rated capacity of the dryer) using the cotton cupboard dry programme
- 4 tests with half load (50% of the rated capacity of the dryer) using the cotton cupboard dry programme
- A total of 7 tests, compared to 15 tests minimum under the current scheme.

According to industrial experts, this would permit to reduce the cost burden of testing (e.g. due to the lower number of tests and quantity of loads to be conditioned and run, etc.), thus improving conditions allowing a more intensive and cost-effective market surveillance, while providing an equal quality of information. Indeed, the half load and easy care programmes have rather similar energy consumptions and account for the "real" behaviour of consumers, and the cotton programme was found to be the most frequently used in Task 3. Moreover, this programme portfolio would be consistent with the one proposed for washing machines, thus ensuring continuity along the laundry care chain.

Calculations and energy efficiency classes definitions

Average drying time

$$T_{av} = (T_{Cpb_dry/100\%} * 3 + T_{Cpb_dry/50\%} * 4) / 7$$

Where:

- T_{av} is the average drying time in hours
- $T_{Cpb_dry/100\%}$ is the drying time to dry a full load (100% of the rated capacity of the dryer) using the cotton cupboard dry programme, measured according to the EN standard
- $T_{Cpb_dry/50\%}$ is the drying time to dry a half load (50% of the rated capacity of the dryer) using the cotton cupboard dry programme, measured according to the EN standard - except for the load

Annual energy consumption

$$AE_c = (3 \cdot E_{Cpb_dry/100\%} + 4 \cdot E_{Cpb_dry/50\%}) / 7 \cdot 160 + \frac{(8760h - 160 \cdot T_{av}[h])}{2} * P_{Off} + \frac{(8760h - 160 \cdot T_{av}[h])}{2} * P_{Left-on}$$

Where:

- AE_c is the annual energy consumption of the dryer, in kWh
- $E_{Cpb_dry/100\%}$ is the energy consumption to dry a full load (100% of the rated capacity of the dryer) using the cotton cupboard dry programme, measured according to the EN standard, in kWh/cycle
- $E_{Cpb_dry/50\%}$ is the energy consumption to dry a half load (50% of the rated capacity of the dryer) using the cotton cupboard dry programme, measured according to the EN standard - except for the load, in kWh/cycle
- $T_{av}[h]$ is the average drying time, in hours
- P_{Off} and $P_{Left-on}$ are the rated power consumptions, respectively in the off-mode and left-on mode, in kW.

Reference annual energy consumption

$$SAE_c = 95 \cdot c[kg] - [T_{av}[h] \cdot 41]_{only_for_vented}$$

Where:

- SAE_c is the "standard" or "reference" annual energy consumption for the dryer technology (air vented or condenser), in kWh
- 95 is the reference annual reference energy consumption, in kWh/kg load/cycle

- c is the maximum cotton load, in kg
- $T_{av}[h]$ is the average drying time, in hours
- 41 is a correction factor to account for the additional energy demand of air vented dryers on space heating

Energy efficiency index

$$EEI = \frac{AE_c}{SAE_c} \times 100$$

Where:

- EEI is the Energy Efficiency Index
- AE_c is the Annual Energy Consumption, in kWh
- SAE_c is the Standard Annual Energy Consumption, which serves as reference for the energy efficiency index, in kWh

Bandwith

- The relative bandwith is calculated with progression but within an intervall of 10%-20%
- The bandwith is defined to be greater or equal to tolerances (10%) but limited to 20%

$$\Delta EEI(\%) = [0.1 + (130 - EEI) * 0.0011] * 100$$

$$10\% \leq \Delta EEI \leq 20\%$$

Energy consumption to be displayed on the label

$$E_c = AE_c / 160$$

This would result in the following layout:

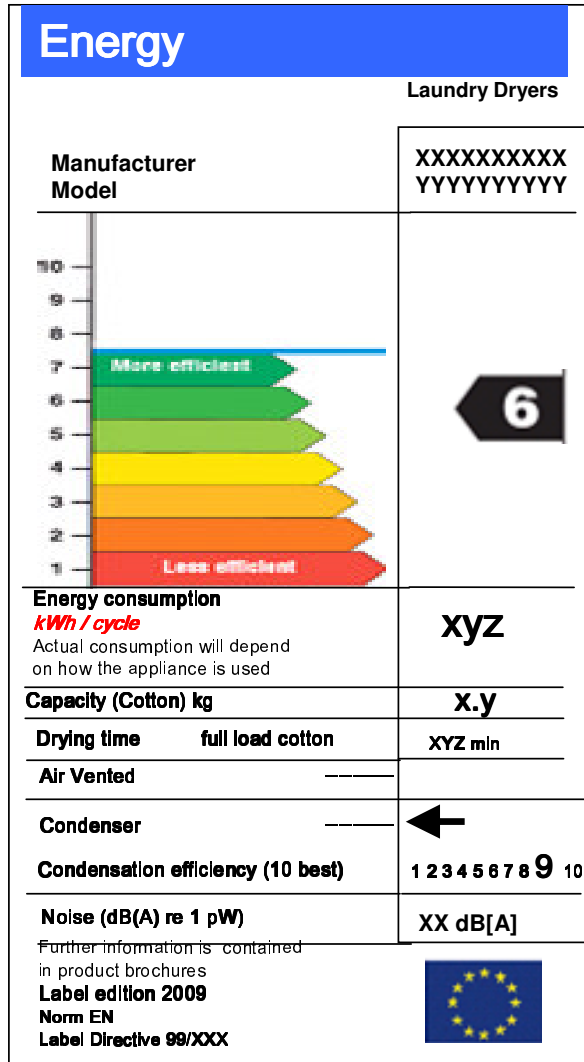

And the following thresholds for the energy efficiency index:

Current energy efficiency classes	New energy efficiency classes	EEl threshold
	10	36
	9	45
A	8	55
B	7	66
C	6	78
D	5	90
E	4	103
F	3	117
G	2	130

X S.A.F.E. proposal for a new tumble dryer label

Updated efficiency classes

During the consultation for this study, S.A.F.E. (Swiss Agency for Efficient Energy Use, which also contributes to the Topten scheme) communicated proposals for updating the label. The basis for the suggestions is explained in the following.

Lately, condenser tumblers classified "B" have appeared. Consumers may appreciate "B" as fairly efficient, while in reality there is a difference of still up to 40% compared to "A" class heat pump devices (> 4 classification steps). Thus, to overcome confusion, it is suggested that the scheme should be shifted to represent the differences. New classifications are proposed: "new 1" corresponds to a shift of 2 steps, which results in some available tumblers in "A", while "new 2" corresponds to a shift of 3 steps, which no appliance will reach "A" at present but should be achieved in the future. Moreover, with the new classifications tumblers in class E (resp. D, "new 2") would become G.

As for vented dryers, as they would also follow the same classification, except that is very unlikely that vented dryers can achieve class A. This means that there would be only appliances in class C and below.

No specific recommendation is made on keeping or removing correction factors to integrate the change in the initial moisture standard conditions. Illustrations and thresholds are provided for both 70 % and 60 % humidity.

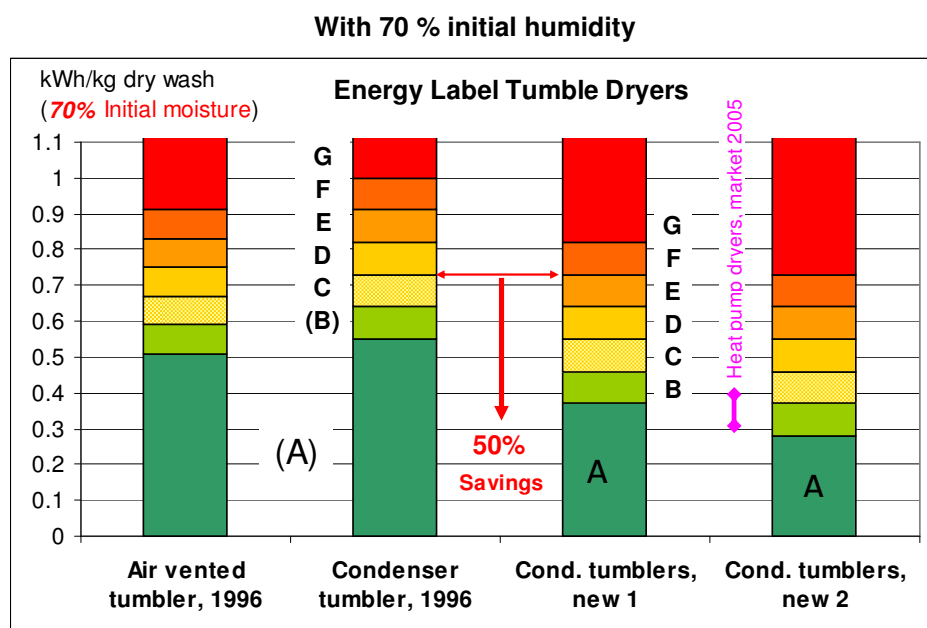

	Air vented tumbler, 1996	Condenser tumbler, 1996	kWh/kg cond.new1	kWh/kg cond.new2
Efficiency class	kWh/kg load	kWh/kg load	kWh/kg load	kWh/kg load
A	0.51	0.55	0.37	0.28
B	0.59	0.64	0.46	0.37
C	0.67	0.73	0.55	0.46
D	0.75	0.82	0.64	0.55
E	0.83	0.91	0.73	0.64
F	0.91	1	0.82	0.73
G	> 0.91	> 1.00	0.91	0.82

With 60 % initial humidity

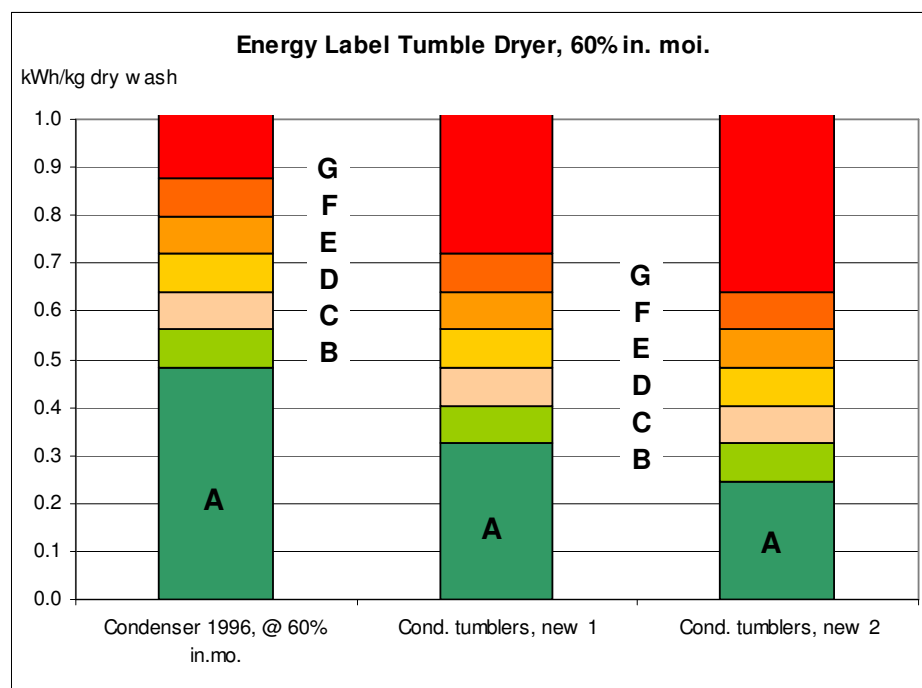

Condenser dryer	1996	Cond.new1	Cond.new2
Efficiency class	kWh/kg load	kWh/kg load	kWh/kg load
A	0.48	0.32	0.25
B	0.56	0.40	0.32
C	0.64	0.48	0.40
D	0.72	0.56	0.48
E	0.80	0.64	0.56
F	0.88	0.72	0.64
G	> 0.88	> 0.72	> 0.64

Y Detailed scenario analysis results

Table 158: Scenario analysis: Electricity consumption (TWh)

	Electricity consumption (TWh)			
	BaU	Conservative	BAT-Moderate	BAT-Ambitious
2005	17.1	17.1	17.1	17.1
2010	19.7	19.6	19.5	19.5
2015	21.4	21.1	20.7	19.8
2020	23.2	22.8	21.6	18.3

Table 159: Scenario analysis: Primary energy consumption (GER, PJ)

	Primary energy consumption (GER, PJ)			
	BaU	Conservative	BAT-Moderate	BAT-Ambitious
2005	191	191	191	191
2010	220	218	218	218
2015	239	236	233	225
2020	260	256	247	219

Table 160: Scenario analysis: GWP (mt CO₂eq.)

	GWP (mt CO ₂ eq.)			
	BaU	Conservative	BAT-Moderate	BAT-Ambitious
2005	8.6	8.6	8.6	8.6
2010	9.9	9.8	9.8	9.8
2015	10.8	10.6	10.5	10.2
2020	11.8	11.6	11.2	10.1

Table 161: Scenario analysis: Energy costs to consumers (million euros)

	Energy costs to consumers (million euros)			
	BaU	Conservative	BAT-Moderate	BAT-Ambitious
2005	2 105	2 105	2 105	2 105
2010	2 427	2 408	2 403	2 403
2015	2 634	2 598	2 561	2 457
2020	2 862	2 813	2 694	2 334

Table 162: Sensitivity analysis (40 % penetration rate): Electricity consumption (TWh)

	Electricity consumption (TWh)			
	BaU	Conservative	BAT-Moderate	BAT-Ambitious
2005	17.1	17.1	17.1	17.1
2010	19.7	19.6	19.5	19.5
2015	21.4	21.1	20.7	19.8
2020	23.2	22.8	21.6	18.3

Table 163: Sensitivity analysis (40 % penetration rate): Primary energy consumption (GER, PJ)

	Primary energy consumption (GER, PJ)			
	BaU	Conservative	BAT-Moderate	BAT-Ambitious
2005	191	191	191	191
2010	220	218	218	218
2015	239	236	233	225
2020	260	256	247	219

Table 164: Sensitivity analysis (40 % penetration rate): GWP (mt CO₂eq.)

	GWP (mt CO ₂ eq.)			
	BaU	Conservative	BAT-Moderate	BAT-Ambitious
2005	8.6	8.6	8.6	8.6
2010	9.9	9.8	9.8	9.8
2015	10.8	10.6	10.5	10.2
2020	11.8	11.6	11.2	10.1

Table 165: Sensitivity analysis (40 % penetration rate): Energy costs to consumers (million euros)

	Energy costs to consumers (million euros)			
	BaU	Conservative	BAT-Moderate	BAT-Ambitious
2005	2 105	2 105	2 105	2 105
2010	2 427	2 408	2 403	2 403
2015	2 634	2 598	2 561	2 457
2020	2 862	2 813	2 694	2 334

Annexes to the final report

Z Minutes of the first stakeholders meeting (Brussels, 3 March 2008)

First meeting with stakeholders, on the Preparatory Study for Ecodesign Requirements of Energy-using-Products (EuP) - Laundry dryers (lot 16) for the European Commission (DG-TREN).

Monday, 3 March 2008, Brussels

The first stakeholder meeting of the **ecodesign of energy-using-products (EuP) – laundry dryers (lot 16)** was organized on 3 March 2008. It was attended by approximately 20 participants (see full list in Annex 1), mainly representing stakeholders from industry.

Agenda

- Welcome and Power point presentation by Matthew Kestner, including:
- Eco design: the concept and its main objectives
- The EuP approach and preparatory studies: purpose, methodology and consultation process
- Power point presentations (PwC Ecobilan), including:
 - Presentation of the consortium partners and project management
 - Progress on Task 1&2: definition of products and classifications, existing standards, existing legislation and voluntary initiatives; economic and market data
 - Proposed scope of the study
- Reactions and discussion
- Power point presentation (CODDE), including:
 - Presentation of Task 3,4&5: Consumer behaviour and local infrastructure; technical analysis of existing products; definition of base case
 - Approach considered and data required for these Tasks
- Reactions and discussion

Summary of discussion

General comments

The process for the EuP preparatory study should be as transparent as possible. In particular, stakeholders are invited to comment on all documents proposed for consultation. They should do so as early as possible so that the study can build up on their inputs.

All available studies and general inputs related to the subject, for example regarding technological, economic and/or social aspects of laundry drying, are welcome. They can be emailed to ecodryers@fr.pwc.com

Some stakeholders suggested to the consultants to take into account the work performed and the main conclusions elaborated in Lot 14 (regarding washing machines) since washing and drying aspects are clearly related.

Task 1: definition of products, existing standards, legislation, labels, etc

It seems that the main products available on the market have been identified and properly defined.

However, the caption of the schematic for the condenser dryer will be modified as it represents an air condenser dryer and not a water condenser dryer (page 10 of the Task 1 draft report for consultation).

It seems that the main relevant standards have been identified.

However, a Chinese standard on which CECED will send more information should be mentioned (from what was said, it is the same as the IEC standard).

A comparison between European and national performance standards/labelling schemes (possibly summarized in the form of a comparative graph) will also be added.

It was confirmed that no international/Europe-wide standards exist for gas dryers. Now, more details on the French standard on commercial and industrial gas appliances will be provided.

It was confirmed that no international/European eco label nor voluntary industry commitment exist for laundry dryers.

Scope of the study

It was proposed to focus on “dry only” (i.e. excluding washer dryers) household appliances (as opposed to commercial and industrial machinery).

Several stakeholders stressed that these were completely different products and technologies, with different production modes, different usage patterns in different settings, which would require a different study if they were to be addressed. It was also noticed that availability of data may be an issue.

Others pointed out that, in particular, it was difficult to define the boundary between commercial and household use, for example in the case of communal use in flats or laundrettes.

The EC suggested that market data and a preliminary consumer behaviour analysis be gathered before deciding on whether to exclude commercial and industrial dryers/use, cabinet dryers and washer dryers from the scope of this study. The technological aspects should also be investigated. The objective is to have a broad picture of their importance in terms of market share and, if possible, environmental impacts (in particular, energy consumption and energy-efficiency) and differences with household use before making a decision on whether they should be studied further or not.

Attention should be paid to avoid leading to a legislative gap that would allow inefficient appliances to be put on the market just because they do not fit in any of the categories concerned by implementing measures of the eco-design Directive (resulting from preparatory studies).

Another important point is to consider the laundry care chain (clothes are usually washed, dried and then ironed. All these steps have an influence on each other which should not be overlooked).

The question of overlapping with Lot 10 (Room air conditioning appliances) was raised concerning drying cabinets. This will be checked by CECED.

Task 2: Economic & market data

Eurostat data are deemed not very reliable (e.g. may include double counts) and much data is missing anyway. Moreover, the classification does not allow enough precision for this study (e.g. distinction between the three main technologies for tumble dryers). Other sources of data are thus required.

The CECED model database and GfK (if available) data should be the sources for data on household appliances.

For commercial and industrial machines, manufacturers present offered to send some data (Electrolux and Primus). Contact will also be engaged with industry associations

and main users (laundrettes, hotels, hospitals, kindergartens, etc) if they can be identified as relevant sources.

Data regarding non automatic washing machines and washer dryers <10kg (Prodcod 29.71.13.50) will be checked as some stakeholders noticed they were unexpectedly high.

Amount of exports should be reviewed since a significant difference has been noted between production and sales data at the European level.

It was pointed out that data concerning trends should be considered with care. For example, trends in consumer habits may result in a higher market share for washer dryers if people want more compact and polyvalent appliances to fit smaller dedicated space and shorter allocated time.

Data should be differentiated according to European "regions"/countries. This is true both for the economic & market data and for data on user behaviour.

Next tasks: Tasks 3, 4&5

The questionnaire should be split between general questions for CECED and specific questions for manufacturers. CECED will make a proposal for the split.

Data required should be carefully thought through and selected in order to avoid having manufacturers collect data that will not be exploited.

The boundaries of the system considered in the study should be defined clearly (e.g. dryer, dryer+room in which it is located, etc).

Different possibilities for base cases have been mentioned, including the possibility of a specific base case for compact dryers (in particular because the efficiency per kg of compact dryers (e.g. 3kg) is not comparable to that of bigger dryers (e.g. 10kg)). However, the final choice will depend on the final decision related to the scope of the study.

Conclusion and next steps

The report prepared by the consortium provided a thorough support for fruitful discussions and was well received by stakeholders. Several stakeholders have offered to provide information to the Consortium (see section below). The consortium would like to thank all participants for their constructive input and feedback.

The following next steps were agreed:

- Stakeholders should submit comments on the draft task 1 report no later than 17 March 2008. The consortium will publish a revised task 1 report shortly thereafter.
- Publication of draft reports for the subsequent tasks are scheduled as follows:
 - Task 2: economic & market analysis: first week of April 2008
 - Task 3: consumer behaviour and local infrastructure: first week of May 2008
 - Task 4: technical analysis of existing products: first week of June 2008.
- The next stakeholder meeting is scheduled to take place on 6, 9 or 10 June 2008 (actual date to be confirmed). All interested stakeholders should reserve these dates. The second stakeholder meeting will cover draft reports for task 2, 3 and 4.
- The draft interim report will be published in June 2008 (+ two week consultation period)
- Meeting with the Commission mid July 2008: Interim report
- First final draft report: early December 2008
- Final report: late January/early February 2009

Documents and data expected from stakeholders

Various stakeholders have committed to provide information and data to the consultant.

- CECED
- Proposal for split of questionnaire between CECED/manufacturers
- Information on the Chinese performance (?) standard
- Check of overlapping with Lot 10 for drying cabinets and data regarding non automatic washing machines and washer dryers <10kg (Procom 29.71.13.50)
- Information on “average” BOM (e.g. for comparison diagram between the different technologies)
- Access to CECED models database
- Relevant available studies (e.g. from Lot 14)
- Danish Technological Institute:
 - Study on the penetration rate of tumble dryers in Denmark and if available, on user habits
- Electrolux, Primus:
 - Market data/ technology data (for comparison with household appliances, e.g. efficiency) of semi-commercial/commercial/industrial machinery
- Indesit:
 - Market data for washer dryers

List of participants

Yoann Baillon (CODDE)
Gianluca Brotto (Electrolux)
Rod Dewey (Indesit)
Onur Durmus (Electrolux)
Milan Janicek (Primus)
Marc Janin (CODDE)
Matthew Kestner (EU Commission DG TREN)
Jorgen Hede Kjeldgaard (Danish Technological Institute/ Advisor for the Danish Energy agency)
Hans Joachim Klug (CECED/Electrolux)
Julie Koskas (PwC, Ecobilan)
Jochen Krimphoff (PwC, Ecobilan)
Clément Lefevre (PwC, Ecobilan)
Ana Patricia López Blanco (CECED)
Francesca Meloni (Indesit)
Ulrich Nehring (GENELEC/Bosch Siemens)
Matteo Rambaldi (CECED)
Claudia.Schoeler (VDMA)
Andreas Schiffleitner (KERP)

AA Minutes of the second stakeholders meeting (Brussels, 6 June 2008)

Second meeting with stakeholders, on the Preparatory Study for Ecodesign Requirements of Energy-using-Products (EuP) - Laundry dryers (lot 16) for the European Commission (DG-TREN).

Monday, 6 June 2008, Brussels

The second stakeholder meeting of the **Ecodesign of energy-using-products (EuP) – laundry dryers (lot 16)** was organized on 6 June 2008. It was attended by approximately 25 participants (see full list in Annex 1), mainly representing stakeholders from industry.

Agenda

Welcome and review of the general planning of the project

- Update on progress to date
 - Task 1: inputs from stakeholders
 - Task 2: main results and inputs from stakeholders
 - Task 3: main results
- Discussion on results from Tasks 2 and 3
- Synthesis of the decisions taken
- Proposal of base case for the study and discussion
- Overview of Tasks 4 and 5
- Methodological aspects
- Overview of data available and needed
- Presentation of questionnaires
- General discussions on afternoon presentations
- Closing of the meeting
- Synthesis of the decisions taken
- Date of the next stakeholders meeting
- Next steps

Summary of discussion

Task 2: main results and inputs from stakeholders

Market data for commercial dryers:

Commercials/industrial dryers: Discussion around dryers in collective housing/laundrettes which are not limited to 10 kilos and used to a much higher frequency than households dryers.

Agreement: Considering the low volume and the lack of information it was agreed to exclude the commercial and industrial dryers from the scope of the study.

Stock Model:

Ownership rates: Ownership rate estimations for both western and eastern Europe were differentiated by the consultant but the penetration rate considered fixed at 36% from 2010 to 2020 was challenged by the stakeholders.

Agreement: The of 36% for Western Europe, proposed by PwC, will be one of the criteria for the sensitivity analysis in Task 8.

Market Trends:

The consultant should explain the following assumption regarding market trends and the use of refrigerants, “the industry might improve the refrigerant gases use in heat pump dryers towards compounds that are more environmentally friendly”.

Task 3: main results of the consumer survey

The question if the consumer survey results were actually representing “the real life behavior” was raised. The answers appeared too “optimistic” to the stakeholders in some of the cases. The following aspects were discussed:

The media of the survey (internet) might imply a sample of young households. As consequence they might possess rather “new” appliances that could explain the age of the driers (rather low) and the high proportion of condenser dryers.

The proportion of moisture control should be higher than the results; the fact that owners do not necessarily know the type of control of their dryer could explain this result. It should be noted that the trend specified in the survey (higher time control) can be influenced by the UK market where the proportion of time control is higher.

The high proportion of dryers belonging to classes A and B was also questioned. This issue can be explained by a high percentage of households which don't know the Energy Efficiency Class of their dryer or overestimate it thinking it might be the “right” answer.

The question of the power switch that might be confused with start button was underlined and highlight that the results have to be considered with caution.

The average capacity of 4.5 kilos appeared too high to the stakeholders. Logically the average load to be considered in the base case should be the same as for washer-dryers defined in Lot 14 (3.4 kg).

CECED indicated that in Poland the market share of washer-dryer is now decreasing.

It was suggested to rename the section, “declared real life behavior” to avoid controversial conclusions.

Agreement: The results of the consumer survey must be challenged and cross-checked with the view of the manufacturers. Manufacturers have agreed to provide inputs in this issue.

Proposal of base case for the study and discussion

After discussions the following agreements were made regarding the base cases:

Two technologies will be studied as two distinct base cases but through the same scheme of analysis of improvement:

Air vented dryers

Condenser dryers

Gas dryers and heat pump will be considered as BAT and will be treated distinctively according to the type of technologies.

Compact dryers will be studied through the base case of Air-vented dryers; therefore this category will not be subject to a specific base case.

Regarding washer-dryer, they will not be treated as a separate base case but it was commonly agreed that the consultant will attempt to qualitatively assess the relevance and feasibility of each potential improvement identified for washer-dryers as well. This work shall be done by the consortium but with strong support from manufacturers.

Automatic control will be defined as the control parameter of both base cases with time control considered as potential improvement with negative impacts.

Front load will be defined as the control parameter of both base cases, nevertheless, top load will be considered through a sensitivity analysis.

The average load should be the same as for washing machine: 3,4 Kg (defined in Lot 14).

Other parameters for the product usage pattern shall depend from the review of the consumer survey with manufacturers.

Seasonality will be taken into account through sensitivity analysis.

Overview of Tasks 4 and 5

Agreed planning:

Questionnaire shall be sent to CECED during the week 24 for review.

CECED will return a feedback on the questionnaire for the 13th of June

Following week the final questionnaire will be sent to manufacturers

Two weeks will be then necessary to CECED to harmonize a global answer from his members in close cooperation with AMDEA members.

Conclusion and next steps

The reports prepared by the consortium provided a thorough support for fruitful discussions and was well received by stakeholders. Key agreements and decisions were made and will allow carrying on efficiently the study. The consortium would like to thank all participants for their constructive input and feedback.

The following next steps were agreed:

- Publication of final reports for the subsequent tasks are scheduled as follows:
- Task 2: Final version with stakeholder comments Second week of June
- Task 3: consumer behavior and local infrastructure: Third week of June (after receiving final comments from stakeholders)
- The draft interim report will be sent to the EC end of June 2008 (+ one month consultation period)
- First final draft report: End of November 2008
- The final **stakeholder meeting** is scheduled to take place on **12 December 2008**. All interested stakeholders should reserve this date.
- Final report: late January/early February 2009

List of participants

Durmus Onur (Electrolux)

Christmann Louise (Whirlpool)

Halatsch Andreas (German Federal Environmental Agency)

Heude Marc (Fagor-Brandt)

Hothersall Jamie (Crosslee)

Janicek Milan (PRIMUS)

Janin Marc (CODDE)

Kestner Matthew (EU Commission DG TREN)

Kjeldgaard Jorgen Hede (Danish Technological Institute)

Klug Hans-Joachim (CECED/Electrolux)

Krimphoff Jochen (PwC, Ecobilan)

Lefèvre Clément (PwC, Ecobilan)
López Blanco Ana Patricia (CECED)
Nehring Ulrich (CENELEC / Bosch-Siemens)
Noll Christian (BUND)
Osset Philippe (PwC, Ecobilan)
Pisano Marco (AMDEA)
Rambaldi Matteo (CECED)
Rojot Camille (PwC, Ecobilan)
Rüdenauer Ina (Öko-Institut) representing consumer interests (BEUC thz
Schoeler Claudia (VDMA)
Schiffleitner Andreas (KERP)
Seiffert Edmund (Bosch-Siemens)
Wendker Christoph (Miele)

BB Final meeting with stakeholders (Brussels, 12 December 2008)

Final meeting with stakeholders, on the Preparatory Study for Ecodesign Requirements of Energy-using-Products (EuP) - Laundry dryers (lot 16) for the European Commission (DG-TREN).

Friday, 12 December 2008, Brussels

The final stakeholders' meeting of the **Ecodesign of energy-using-products (EuP) – laundry dryers (lot 16)** was organized on 12 December 2008. It was attended by approximately 20 participants (see full list in Annex 1), mainly representing stakeholders from industry and NGOs.

Agenda

- Welcome and review of the general planning of the project
- Update on progress to date
- Next steps and milestones
- Task 1-6: main results and inputs from stakeholders, discussion
- Task 7: main results, discussion
- General discussions on afternoon presentations
- Closing of the meeting
- Synthesis of the decisions taken
- Date of the next stakeholders meeting
- Next steps

Summary of discussion

Task 1

Some stakeholders asked whether specific works would be performed during Lot 16 regarding *Washer-dryers*. As previously discussed in past stakeholder meetings, the consultant explained that washer dryers were excluded from the scope of this study mainly because their primary function is similar to that of washing machines rather than dryers, and they have a small volume of sales and market share (<200 000 units). Therefore no specific work regarding washer dryers will be performed in Lot 16.

Nevertheless, the issue raised by stakeholders regarding washer dryers should be addressed by DG Tren in the future, for example through the Impact Assessment study.

Task 2-3

The reminder of the main results of these tasks did not raise particular comments.

Task 4-5

The following comments have been received during the meeting:

Clogging of the filter - influence on energy consumption in the real life base case: few data are available: industrials indicate that there is no influence for up to 5-6 runs without

cleaning. Moreover, there usually are indicators to signal clogging to users and, if the filter is fully clogged, the appliance heats up and shuts down for security reasons, making it impossible for users to carry out the drying process. The influence of clogging will thus not be accounted for quantitatively but it is mentioned qualitatively.

Additional energy demand on space heating – the influence of dryers on local systems (especially for air vented dryers) could be considered in a sensitivity analysis in Task 8. It should be noted that the consultant requires specific additional information to perform this work, for example through information gathered through field test measures and published in literature.

Type of control. The base case assumes humidity control.

Particulates from fluff. The order of magnitude of particulates released in the environment is similar for air vented dryers to that when clothes are worn, none occur for condenser dryers (cf. closed circuit and filters).

Task 6

Gas dryers, dryers coupled with district heating, etc- systems analysis: the main issues with these technologies are mainly the energy mix to produce the energy used and the interactions with the room heating system rather than how the dryer performs the drying function. This makes it hard to compare them with the base cases in the framework of this methodology. Sensitivity analyses in Task 8 will be performed. Moreover, the question of using a factor accounting for the efficiency of using primary energy for gas dryers was raised.

Heat pump dryers – Refrigerants: the market is evolving and the evolution will depend on the offer proposed by the chemical industry (which in turn may be influenced by the demand for HP dryers)

Task 7

Heat pump dryers – costs analysis: a design engineering costs analysis of HP dryers would add more insight into where the additional costs come from and would be a valuable element in the cost analysis. A sensitivity analysis regarding HP dryer costs will be performed in Task 8.

Condensation efficiency: this parameter should be considered in the sensitivity analysis for interactions with local systems if data are available.

Air vented v. condenser dryers: life cycle environmental impacts and costs of the two base cases and those of the most promising options will be compared on a unique graph for both technologies, to ease the comparison between them as they perform the same function.

Energy costs: the costs of energy (electricity/gas) play a major role in determining what is cost-effective and what is not when it comes to EuPs in general, and tumble dryers in particular. There may be a strong dependency on the country of location of the dryer. Therefore, it was agreed that the consultant should perform a sensitivity analysis for energy costs taking into account the energy prices in the countries where the laundry dryer market shares are highest. In a first analysis, stakeholders proposed to consider countries such as UK, France, Germany, Benelux, Denmark, Sweden and/or Spain.

Conclusion and next steps

The reports prepared by the consortium provided a thorough support for fruitful discussions and were well received by stakeholders. The discussions and agreements achieved during this meeting will allow the study to be completed effectively and to tackle the main issues relating to tumble dryers.

The consortium would like to thank all participants for their constructive input and feedback.

The following next steps were agreed:

- Addition of appropriate elements discussed during the meeting in relevant tasks' reports
- Publication of final and draft reports for the subsequent tasks are scheduled as follows:
 - Task 7: Final version with stakeholder comments: Last week of December
 - Task 8: Draft version sent to the EC by Friday 9 January
 - The draft final report (Tasks 1 – 7) will be sent to the EC at the end of December 2008

List of participants

Christmann Louise (Whirlpool)
Dewey Rod (Indesit)
Gensch Carl-Otto (Öko-Institut), representing consumer interests
Hothersall Jamie (Crosslee)
Jager Hans (Natuur en Milieu), on behalf of ECOS
Janicek Milan (Primus)
Kestner Matthew (EU Commission DG TREN)
Kjeldgaard Jorgen Hede (Danish Technological Institute)
Koskas Julie (PwC, Ecobilan)
Lefèvre Clément (PwC, Ecobilan)
Lescuyer Linda (CODDE)
López Blanco Ana Patricia (CECED)
Nehring Ulrich (CENELEC / Bosch-Siemens)
Orgelet Julie (CODDE)
Pratt Thierry (Fagor-Brandt)
Rambaldi Matteo (CECED)
Schiffleitner Andreas (KERP)
Wendker Christoph (Miele)